

EOL9-1503-20 Series

Single-Mode 155Mbps 1550nm
 Duplex 1 x 9 Transceiver
 RoHS6 Compliant

Features

- ◆ Duplex SC/FC/ST Single-Mode Transceiver
- ◆ Industry Standard 1 x 9 Footprint
- ◆ 1550nm FP-LD Transmitter
- ◆ 3.3V or 5V single power supply
- ◆ PECL signal input and output, supporting 125Hz signaling ^{*note1}
- ◆ Signal detect indicator (PECL version) ^{*note1}
- ◆ Wave Solderable and Aqueous Washable with process plug inserted
- ◆ Class 1 FDA and IEC60825-1 laser safety compliant
- ◆ 20Km with 9/125 um SMF at Least
- ◆ Operating Case Temperature
 Standard: 0°C~+70°C,
 Industrial:-40°C~+85°C



Applications

- ◆ ATM 155 Mbps Links
- ◆ SONET/SDH Equipment Interconnect
- ◆ Switch to Switch Interface
- ◆ Digital video transmission system

Ordering information

Part No.	Input	Output	SD	Distance	Voltage	Interface	Temp.
EOL9-1503-20 ^{*note2}	DC	DC	PECL	20Km	3.3V/5V	SC	Standard
EOL9-1503-20I	DC	DC	PECL	20Km	3.3V/5V	SC	Industrial
EOL9-1503-201	AC	AC	PECL	20Km	3.3V/5V	SC	Standard
EOL9-1503-201I	AC	AC	PECL	20Km	3.3V/5V	SC	Industrial

*Other ordering information in detail refers to the denominate rule on next page.

Note1: 5V for PECL or TTL, 3.3V for LVPECL or LVTTTL

Note2: Standard version

Nomenclature

Symmetrical 1X9 Duplex

EOL9- -

A B C D E F G H I J K L

No.	Parameter	Detailed Description					
A	Module Type	9=1X9					
B	blank						
C	Wavelength	85=850nm		13=1310nm		15=1550nm	
D	Data Rate	01=0.5M	02=1~100M	03=155M	06=622M	12=1.25G	24=2.5G
E	Blank						
F	Distance	02=850nm, MMF			XM=X Km (1310nm, MMF, X=1~9)		
		X=X *10Km (SM,X=1~9)			A=100Km		
G	Blank						
H	Blank						
I	Temperature	I=-40~+85 <input type="checkbox"/>			Blank=0~+70 <input type="checkbox"/>		
J	Connector	Blank=SC	T=ST	F=FC	P=Pigtail/ SC/PC	PF=Pigtail/ FC/PC	PT=Pigtail/ ST/PC
K	Voltage	Blank=3.3/5V		V=3.3V		H=5V	
L	Input/output & SD	Blank=Input: DC; Output: DC; SD-TTL (FC/GBE/2FC/OC48).			Blank=Input: DC; Output: DC; SD-PECL (OC-3/STM-4).		
		1=Input: AC; Output: AC; SD-TTL (FC/GBE/2FC/OC48).			1=Input: AC; Output: AC; SD-PECL (OC-3/STM-4).		
		2= Input: DC; Output: DC; SD-PECL (FC/GBE/2FC/OC48).			2=Input: DC; Output: DC; SD-TTL (OC-3/STM-4).		
		3= Input: AC; Output: AC; SD-PECL (FC/GBE/2FC/OC48).			3= Input: AC; Output: AC; SD-TTL (OC-3/STM-4).		

Regulatory Compliance

Feature	Standard	Performance
Electrostatic Discharge (ESD) to the Electrical Pins	MIL-STD-883G Method 3015.7	Class 1C (>1000 V)
Electrostatic Discharge to the enclosure	EN 55024:1998+A1+A2 IEC-61000-4-2 GR-1089-CORE	Compliant with standards
Electromagnetic Interference (EMI)	FCC Part 15 Class B EN55022:2006 CISPR 22B :2006 VCCI Class B	Compliant with standards Noise frequency range: 30 MHz to 6 GHz. Good system EMI design practice required to achieve Class B margins.

The Signal Detect (SD, active high), Normal optical input of receiver represents to a logic “1” level, which means asserted.

The following versions are available:

1. AC/AC Transceiver

Tx and Rx are AC coupling. Tx has differential 100Ω load.

2. DC/DC Transceiver

Standard PECL inputs and outputs, Tx and Rx are DC coupling.

Product Description

The EOL9-1503-20 Series Single-mode transceivers are low power, high performance modules for duplex optical data communications such as SONET OC-3/SDH STM-1 and Fast Ethernet.

The transmitter section uses a multiple quantum well FP laser and is a class1 laser compliant according to International Safety Standard IEC-60825. The receiver section uses an integrated InGaAs detector preamplifier (IDP) mounted in an optical header and a limiting post-amplifier IC.

A PECL logic interface simplifies interface to the external circuitry.

Absolute Maximum Ratings

Parameter	Symbol	Min.	Max.	Unit	
Storage Temperature	T _s	-40	+85	°C	
Supply Voltage	VCC	5V	-0.5	7.0	V
		3.3V	-0.5	5.5	
Operating Relative Humidity	-		95	%	
Soldering Conditions Temp/Time			260/10	°C/s	

*Exceeding any one of these values may destroy the device immediately.

Recommended Operating Conditions

Parameter	Symbol	Min.	Typical	Max.	Unit
Operating Case Temperature	T _A	0		+70	°C
		-40		+85	
Power Supply Voltage	VCC	4.75	5	5.25	V
		3.15	3.3	3.45	
Power Supply Current ^(note4)	I _{cc}			300	mA
Data Rate			155		Mbps

Note4: Maximum current is specified at Vcc equaling to Maximum @ maximum temperature.

Optical and Electrical Characteristic

(EOL9-1503-20 Series, FP and PIN)

Parameter	Symbol	Min.	Typical	Max.	Unit
Transmitter					
Centre Wavelength	λ_c	1480	1550	1580	nm
Spectral Width	$\Delta \lambda$			4	nm
Average Output Power ^{*(note5)}	P_{out}	-15		-8	dBm
Extinction Ratio	ER	9			dB
Rise/Fall Time (20%---80%)	tr/tf			2	ns
Relative Intensity Noise	RIN			-117	dB/Hz
Total Jitter	TJ			1	ns
Data Input Swing Differential	V_{in}	400		2000	mV
Input Differential Impedance	Z_{in}	90	100	110	Ω
Input High Voltage	V_H	-1165		-880	mV
Input Low Voltage	V_L	-1810		-1475	mV
Eye Diagram	IUT-T G.957 Compliant ^{*(note7)}				
Data Input	PECL ^{*(note1)}				
Receiver					
Receiver Rate	155				Mbps
Input center wavelength	λ_c	1260		1620	nm
Receiver Sensitivity ^{*(note6)}	P_{min}			-34	dBm
Receiver Overload	P_{max}	-5			dBm
SD Assert	SDA			-35	dBm
SD De-Assert	SDD	-45			dBm
SD Hysteresis ^{*(note8)}		0.5			dB
Output High Voltage	V_H	-1165		-880	mV
Output Low Voltage	V_L	-1810		-1475	mV
SD Voltage(TTL-H) ^{*(note1)}	V_H	2			V
SD Voltage (TTL-L) ^{*(note1)}	V_L			0.8	V
SD Voltage(PECL-H) ^{*(note1)}	V_H	-1.1		-0.74	V
SD Voltage (PECL-L) ^{*(note1)}	V_L	-2.0		-1.58	V
Data Output	PECL ^{*(note1)}				

Note5: The optical power is launched into 9/125um SMF.

Note6: Minimum average optical power at which the BER is less than 1E-12 or lower. Measured with a 2^{23} -1 NRZ PRBS and ER=9 dB.

Note7: Eye pattern mask

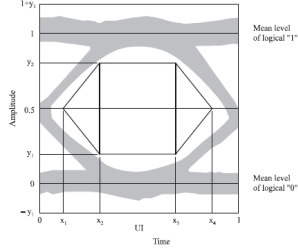

Note8: LOS Hysteresis

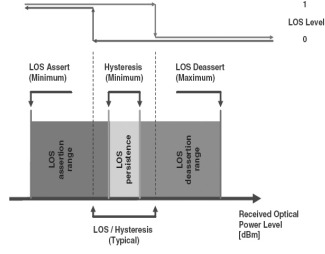

Pin Description

Pin	Name	Level	Description
1	Veer		Receiver Signal Ground, connect to receiver signal ground plane directly
2	RD+	PECL ^{*(note1)}	Receiver data out
3	RD-	PECL ^{*(note1)}	Inverted receiver data out
4	SD	PECL ^{*(note1)}	Signal Detect, TTL (Load resistor > 4.7KΩ)or PECL output, Normal optical input levels to the receiver result in a logic "1" output, asserted. Low input levels to the receiver result in a fault condition indicated by a logic "0"output, de-asserted.
5	Vccr		Receiver Power Supply, provide +5V (+3.3V) the recommended receiver power supply filter circuit. Locate the power filter circuit as close as possible to the Vccr pin
6	Vcct		Transmitter Power Supply, provide +5V DC(+3.3V) via the recommended transmitter power supply filter circuit. Locate the power filter circuit as close as possible to the Vcct pin
7	TD-	PECL ^{*(note1)}	Inverted transmitter Data in
8	TD+	PECL ^{*(note1)}	Transmitter Data in
9	Veet		Transmitter Signal Ground, connect to the transmitter signal ground planed directly

Pin Definitions

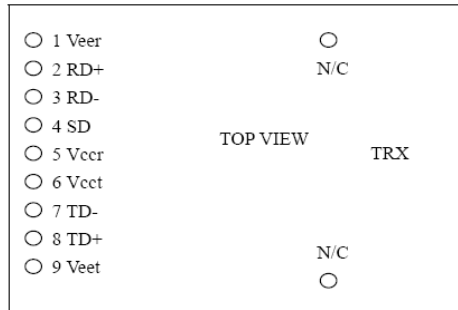

Recommended Circuit

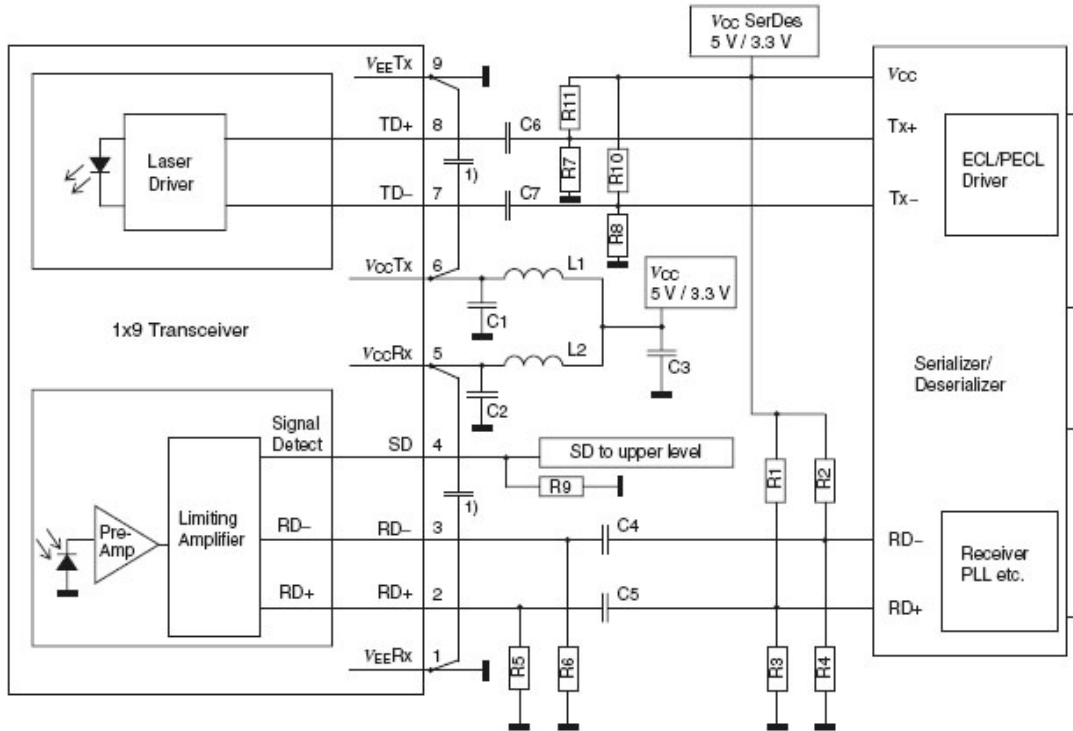

- C1/2/3 = 4.7 μ F
- C4/5/6/7 = 100 nF
- L1/2 = 1 μ H
- R5/6 = 270 Ω (5 V)
- = 150 Ω (3.3 V)
- R7/8 = 127 Ω (5 V)
- = 82 Ω (3.3 V)
- (depends on SerDes chip used)
- R9 = 510 Ω (5 V)
- = 270 Ω (3.3 V)

- R10/11 = 82 Ω (5 V)
- = 127 Ω (3.3 V)
- (depends on SerDes chip used)
- Place R1/2/3/4 close to SerDes chip, depends on SerDes chip used.
- Place R5/6/7/8/10/11 close to 1x9 transceiver.

DC Coupling inside

Package outline (Unit: mm)

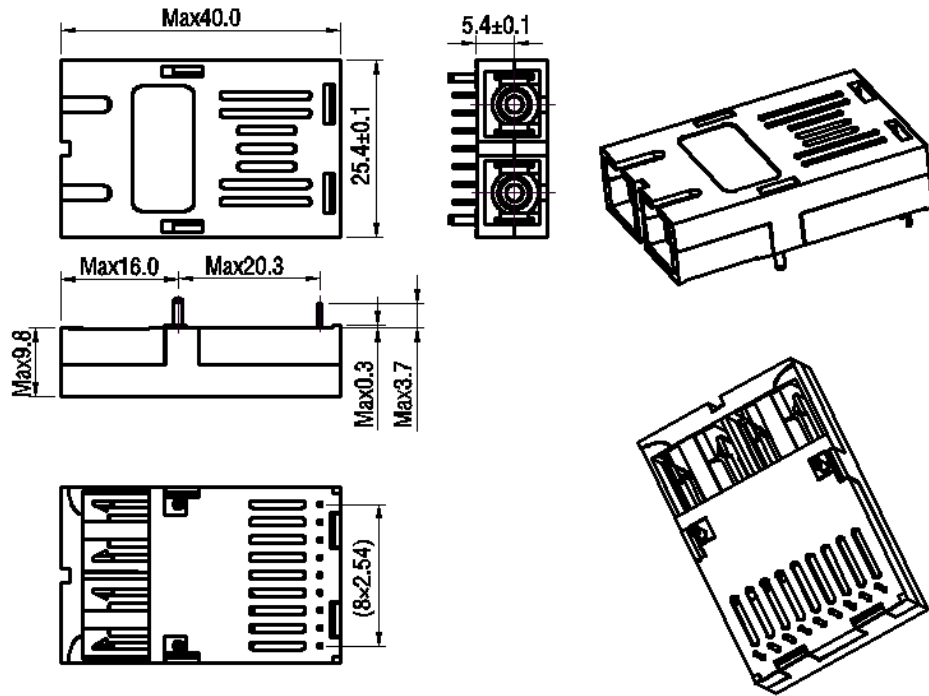

SC receptacle

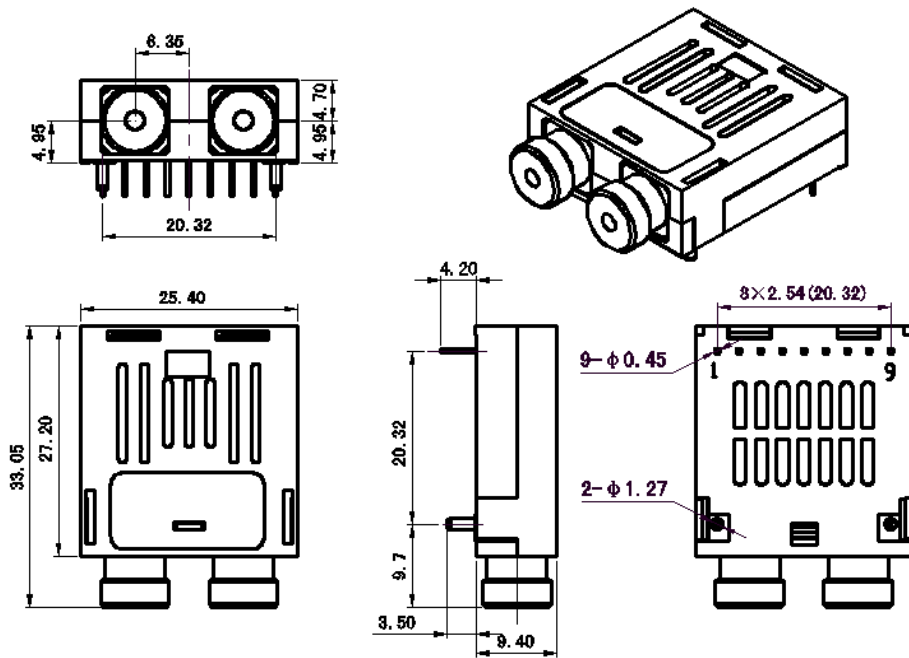

FC receptacle

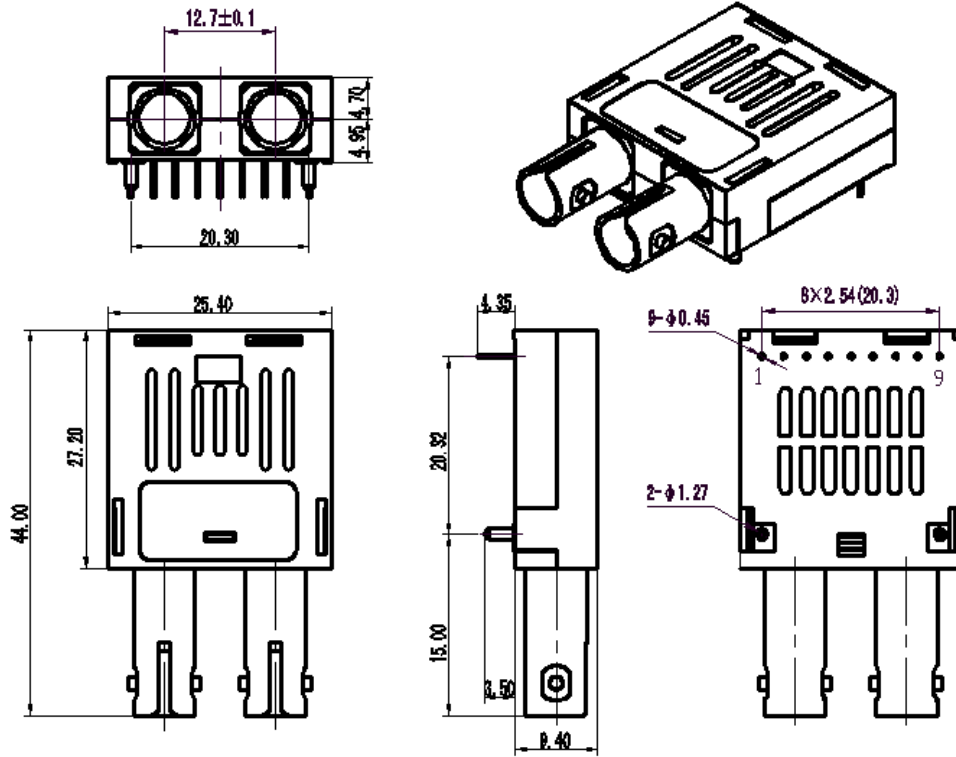

ST receptacle

Class 1 Labels

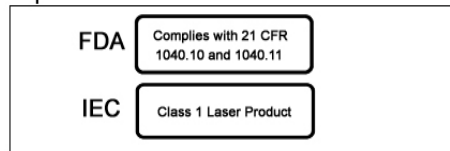

Laser Emission Data

Wavelength	1550nm
Total output power (as defined by FDA: 7 mm aperture at 20 cm distance)	< 0.195mW
Total output power (as defined by IEC: 7 mm aperture at 10 cm distance)	< 15.6mW
Beam divergence	12.5°

Laser Emission

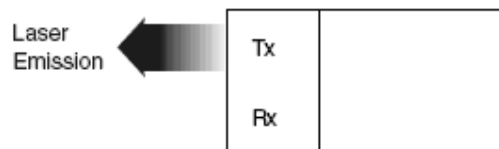

Obtaining Document

You can visit our website:

<http://www.eoptolink.com>

Or contact Eoptolink Technology Inc., Ltd. listed at the end of the documentation to get the latest documentation.

Revision History

Revision	Initiated	Reviewed	Approved	DCN	Release Date
V2.a	Tim.Liang	Kelly.Cao		Released.	2007-3-27
V2.b	Kelly			Change logo.	2010-1-12

Notice:

Eoptolink reserves the right to make changes or discontinue any product or service identified in this publication, without notice, in order to improve design and/or performance. Applications that are described herein for any of the products are for illustrative purposes only. Eoptolink makes no representation or warranty that such applications will be suitable for the specified use without further testing or modification.

Contact:

Add: Floor 5 Building 2 No. 21 Gaopeng Avenue High-Tech District CHENGDU, SICHUAN 610041

P.R. CHINA

Tel: (+86) 028-85122709 ext 816 & 809

Fax: (+86) 028-85121912

Postal: 610041

E-mail:sales@eoptolink.com

<http://www.eoptolink.com>