

EOL9-8512-02-X Series

**Multi-Mode 850nm GBE
Duplex 1 x 9 Transceiver
RoHS6 Compliant**

Features

- ◆ Duplex SC Multi-Mode Transceiver
- ◆ Industry Standard 1 x 9 Footprint
- ◆ Operating data rate up to 1.25Gbps
- ◆ 850nm VCSEL Laser Transmitter
- ◆ 550m with 50/125 μ m MMF
300m on 62.5/125 μ m MMF
- ◆ 3.3V or 5V single power supply
- ◆ PECL signal input and output ^{*note1}
- ◆ Signal detect indicator ^{*note1}
- ◆ Wave Solderable and Aqueous Washable
with process plug inserted
- ◆ Class 1 FDA and IEC60825-1 laser safety
compliant
- ◆ Operating Case Temperature
Standard: 0°C~+70°C
Industrial:-40°C~+85°C



Applications

- ◆ Gigabit Ethernet
- ◆ Fiber channel
- ◆ Switch to Switch Interface
- ◆ Digital video transmission system

Ordering information

Part No.	Input	Output	SD	Distance	Voltage	Interface	Temp.
EOL9-8512-02-UH ^{*note2}	DC	DC	PECL	550m	5V	SC	Standard
EOL9-8512-02-IUH ^{*note2}	DC	DC	PECL	550m	5V	SC	Industrial

*Other ordering information in detail refers to the denominate rule on next page.

Note1: 5V for PECL or TTL, 3.3V for LVPECL or LVTTTL

Note2: Standard version

Nomenclature

Symmetrical 1X9 Duplex

EOL□-□□□-□-□-□□□□□□□□

A-BCD-E-F-GHIJKLMN

No.	Description	Option
A	Package	9=1x9
B	Laser Type	Blank=Duplex
C	Wavelength	85 =850nm;
D	Data Rate	12=1.25G;
E	Module Type	Blank=Transceiver
F	Distance ^{*note1}	850nm MMF ≤2km: 02;
G	Power budget ^{*note1}	XX, X=1, 2, 3 ...9 and 0, for CWDM/DWDM only.
H	CWDM Tx & Rx Wavelength	CWDM: Refer the following table1, A~R; DWDM (100GHZ): Refer the following table2, 15~61. DWDM (50GHZ): Refer the following table3 C-Band,
I	DDM	Blank=Non DDM D=DDM
J	Temp.	Blank=0~70°C ; I=-40~+85°C (include the extended temperature)
K	Others	Blank=SC; T=ST Plastics ;M = ST Metal; F=FC; N=FC Plastics; P=Pigtail/SC/PC; PF=Pigtail/FC/PC; PT=Pigtail/ST/PC
L	Input/Output & SD ^{*note2}	Blank: AC/AC SD-TTL Q: AC/AC SD-PECL R: DC/DC SD-TTL U: DC/DC SD-PECL W: AC/DC SD-TTL X: AC/DC SD-PECL Y: DC/AC SD-TTL Z: DC/AC SD-PECL 0: AC/AC LOS-TTL 1: AC/AC LOS-PECL 2: DC/DC LOS-TTL 3: DC/DC LOS-PECL 4: AC/DC LOS-TTL 5: AC/DC LOS-PECL 8: DC/AC LOS-TTL 9: DC/AC LOS-PECL

		J: DC for single or duplex TX or RX k: AC for single or duplex TX or RX
M	Voltage	Blank=3.3/5V; V=3.3V; H=5V
N	Case type	Blank= Duplex M=BIDI Middle Export S= BIDI Side Export

*Note: The content for J, K, L, M are customized information, standard product does not include them.

*Note1: The distance and power budget should not be appeared in our PN at the same time. We recommend using power budget in our PN for CWDM/DWDM

*Note2: The Input/Output & SD is from "Q" to "Z" and "0" to "9", kick out "S" "T" "V" "6" "7" for the confusion with "BIDI Side Export" "ST Plastics" "FC" "3.3V" "2X6" "2X7"

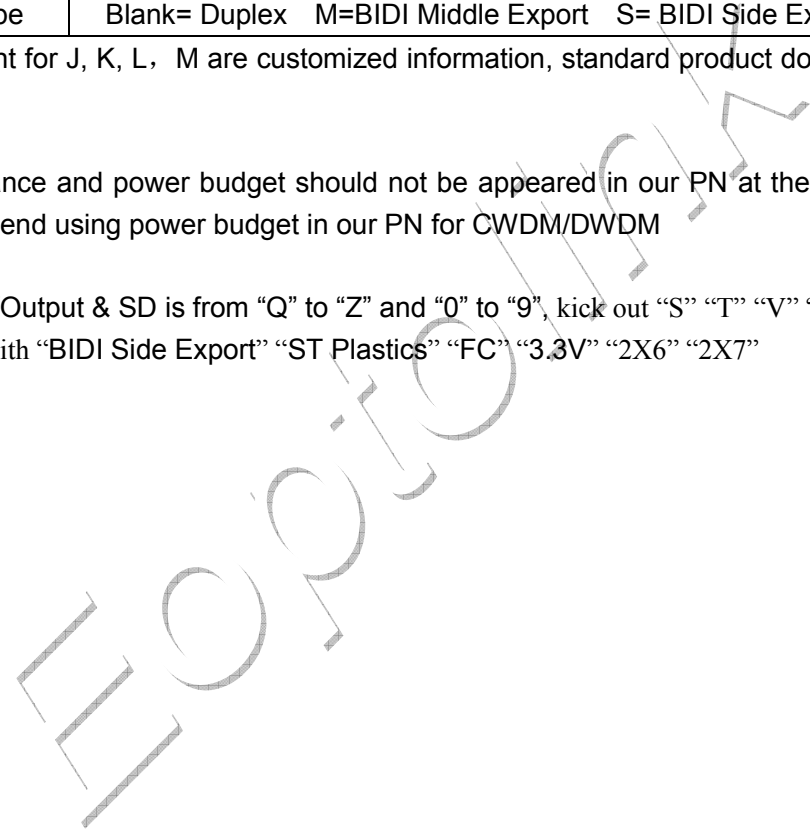

Regulatory Compliance

Feature	Standard	Performance
Electrostatic Discharge (ESD) to the Electrical Pins	MIL-STD-883G Method 3015.7	Class 1C (>1000 V)
Electrostatic Discharge to the enclosure	EN 55024:1998+A1+A2 IEC-61000-4-2 GR-1089-CORE	Compliant with standards
Electromagnetic Interference (EMI)	FCC Part 15 Class B EN55022:2006 CISPR 22B :2006 VCCI Class B	Compliant with standards Noise frequency range: 30 MHz to 6 GHz. Good system EMI design practice required to achieve Class B margins. System margins are dependent on customer host board and chassis design.
Immunity	EN 55024:1998+A1+A2 IEC 61000-4-3	Compliant with standards. 1kHz sine-wave, 80% AM, from 80 MHz to 1 GHz. No effect on transmitter/receiver performance is detectable between these limits.
Laser Eye Safety	FDA 21CFR 1040.10 and 1040.11 EN (IEC) 60825-1:2007 EN (IEC) 60825-2:2004+A1	CDRH compliant and Class I laser product. TüV Certificate No. 50135086
Component Recognition	UL and CUL EN60950-1:2006	UL file E317337 TüV Certificate No. 50135086 (CB scheme)
RoHS6	2002/95/EC 4.1&4.2 2005/747/EC 5&7&13	Compliant with standards ^{*note3}

Note3: For update of the equipments and strict control of raw materials, EOPTOLINK has the ability to supply the customized products since Jan 1st, 2007, which meet the requirements of RoHS6 (Restrictions on use of certain Hazardous Substances) of European Union.

In light of item 5 in RoHS exemption list of RoHS Directive 2002/95/EC, Item 5: Lead in glass of cathode ray tubes, electronic components and fluorescent tubes.

In light of item 13 in RoHS exemption list of RoHS Directive 2005/747/EC, Item 13: Lead and cadmium in optical and filter glass. The three exemptions are being concerned for Eoptolink's transceivers, because Eoptolink's transceivers use glass, which may contain Pb, for optical components such as lenses, isolators, and other electronic components.

Functional Diagram

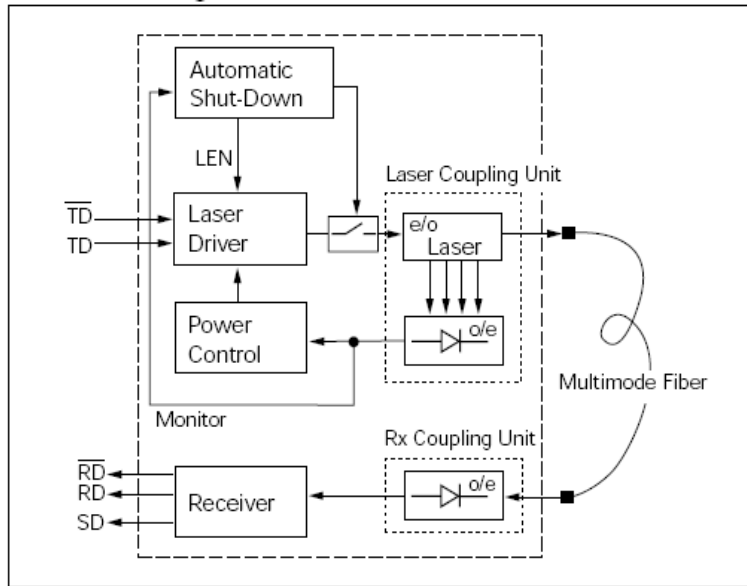

The Signal Detect (SD, active high), Normal optical input of receiver represents to a logic “1” level, which means asserted.

The following versions are available:

1. AC/AC Transceiver

Tx and Rx are AC coupling. Tx has differential 100Ω load.

2. DC/DC Transceiver

Standard PECL inputs and outputs, Tx and Rx are DC coupling.

Product Description

The EOL9-8512-02 series multi-mode transceivers is low power, high performance module for duplex optical data communications such Gigabit Ethernet and Fiber Channel. This module is designed for multi-mode fiber and operates at a nominal wavelength of 850 nm.

The transmitter section uses a Vertical Cavity Surface Emitted Laser (VCSEL) and is a Class 1 laser compliant according to International Safety Standard IEC 60825. The receiver section uses an integrated GaAs detector preamplifier (IDP) mounted in an optical header and a limiting post-amplifier IC.

Absolute Maximum Ratings

Parameter	Symbol	Min.	Max.	Unit
Storage Temperature	T _s	-40	+85	°C
Supply Voltage	VCC 5V	-0.5	7.0	V

		3.3V	-0.5	5.5	
Operating Relative Humidity		-		95	%
Soldering Conditions Temp/Time				260/10	°C/s

*Exceeding any one of these values may destroy the device immediately.

Recommended Operating Conditions

Parameter	Symbol	Min.	Typical	Max.	Unit
Operating Case Temperature	T_A	0		+70	°C
		-40		+85	
Power Supply Voltage	VCC	4.75	5	5.25	V
		3.15	3.3	3.45	
Power Supply Current ^{*(note4)}	I _{cc}			300	mA
Data Rate			1250		Mbps

Note4: Maximum current is specified at Vcc equaling to Maximum @ maximum temperature.

Optical and Electrical Characteristic

(EOL9-8512-02 Series, VCSEL and PIN)

Parameter	Symbol	Min.	Typical	Max.	Unit
Transmitter					
Centre Wavelength	λ_C	840	850	860	nm
RMS Spectral Width	$\Delta\lambda$			0.85	nm
Average Output Power ^{*(note5)}	P _{out}	-9.5		-4	dBm
Extinction Ratio	ER	9			dB
Rise/Fall Time(20%~80%)	tr/tf			260	ps
Data Input Swing Differential	V _{in}	400		2000	mV
Input Differential Impedance	Z _{in}	90	100	110	Ω
Input High Voltage	V _H	-1165		-880	mV
Input Low Voltage	V _L	-1810		-1475	mV
Eye Diagram	IEEE802.3z and ANSI Fibre Channel Compliant ^{*(note7)}				
Data Input	PECL ^{*(note1)}				
Receiver					
Receiver Rate	1250				Mbps
Input center wavelength	λ_C	760		860	nm

Receiver Sensitivity ^{*(note6)}	Pmin			-17	dBm
Receiver Overload	Pmax	-3			dBm
SD Assert	SDA			-18	dBm
SD De-Assert	SDD	-35			dBm
SD Hysteresis ^{*(note8)}		0.5			dB
Output High Voltage	V _H	-1165		-880	mV
Output Low Voltage	V _L	-1810		-1475	mV
SD Voltage(TTL-H) ^{*(note1)}	V _H	2			V
SD Voltage (TTL-L) ^{*(note1)}	V _L			0.8	V
SD Voltage(PECL-H) ^{*(note1)}	V _H	-1.1		-0.74	V
SD Voltage (PECL-L) ^{*(note1)}	V _L	-2.0		-1.58	V
Data Output	PECL ^{*(note1)}				

Note5: The optical power is launched into 50/125um MMF.

Note6: Minimum average optical power at which the BER is less than 1E-12 or lower. Measured with a 2⁷-1 NRZ PRBS and ER=9 dB.

Note7: Eye pattern mask

Note8: LOS Hysteresis

Pin	Name	Level	Description
1	Veer		Receiver Signal Ground, connect to receiver signal ground plane directly
2	RD+	PECL ^{*(note1)}	Receiver data out
3	RD-	PECL ^{*(note1)}	Inverted receiver data out
4	SD	PECL ^{*(note1)}	Signal Detect, TTL (Load resistor > 4.7KΩ)or PECL output, Normal optical input levels to the receiver result in a logic "1" output, asserted. Low input levels to the receiver result in a fault condition indicated by a logic "0"output, de-asserted.
5	Vccr		Receiver Power Supply, provide +5V (+3.3V) the recommended receiver power supply filter circuit. Locate the power filter circuit as close as possible to the Vccr pin
6	Vcct		Transmitter Power Supply, provide +5V DC(+3.3V) via the recommended transmitter power supply filter circuit. Locate the power filter circuit as close as possible to the Vcct pin
7	TD-	PECL ^{*(note1)}	Inverted transmitter Data in
8	TD+	PECL ^{*(note1)}	Transmitter Data in
9	Veet		Transmitter Signal Ground, connect to the transmitter signal ground planed directly

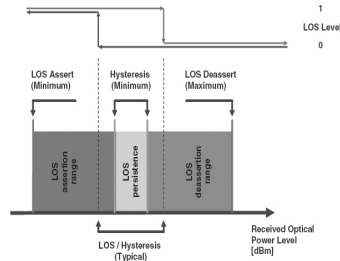
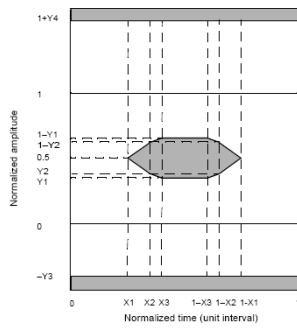

Pin Description

Pin	Name	Level	Description
1	Veer		Receiver Signal Ground, connect to receiver signal ground plane directly
2	RD+	PECL ^{*(note1)}	Receiver data out
3	RD-	PECL ^{*(note1)}	Inverted receiver data out
4	SD	PECL ^{*(note1)}	Signal Detect, TTL (Load resistor > 4.7KΩ)or PECL output, Normal optical input levels to the receiver result in a logic “1” output, asserted. Low input levels to the receiver result in a fault condition indicated by a logic “0”output, de-asserted.
5	Vccr		Receiver Power Supply, provide +5V (+3.3V) the recommended receiver power supply filter circuit. Locate the power filter circuit as close as possible to the Vccr pin
6	Vcct		Transmitter Power Supply, provide +5V DC(+3.3V) via the recommended transmitter power supply filter circuit. Locate the power filter circuit as close as possible to the Vcct pin
7	TD-	PECL ^{*(note1)}	Inverted transmitter Data in
8	TD+	PECL ^{*(note1)}	Transmitter Data in
9	Veet		Transmitter Signal Ground, connect to the transmitter signal ground planed directly

Pin Definition

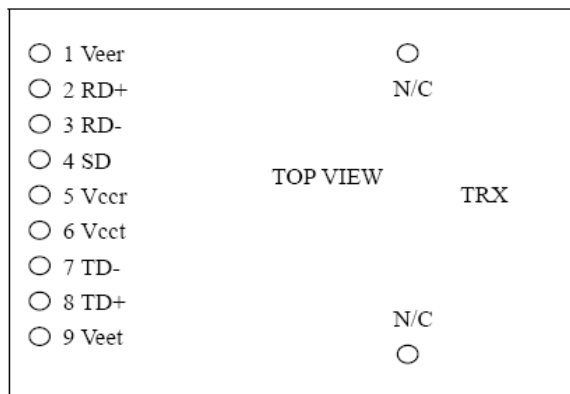

Recommended Circuit

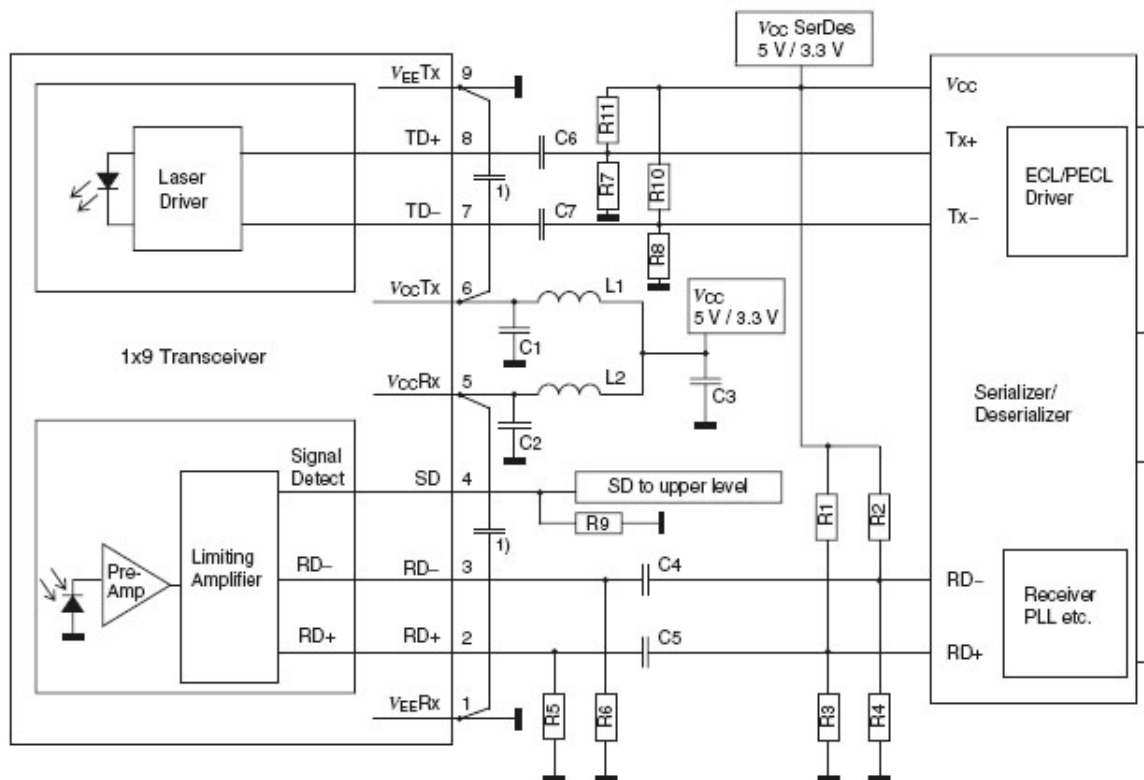

- C1/2/3 = 4.7 μ F
- C4/5/6/7 = 100 nF
- L1/2 = 1 μ H
- R5/6 = 270 Ω (5 V)
= 150 Ω (3.3 V)
- R7/8 = 127 Ω (5 V)
= 82 Ω (3.3 V)
- (depends on SerDes chip used)
- R9 = 510 Ω (5 V)
= 270 Ω (3.3 V)

- R10/11 = 82 Ω (5 V)
= 127 Ω (3.3 V)
- (depends on SerDes chip used)
- Place R1/2/3/4 close to SerDes chip, depends on SerDes chip used.
- Place R5/6/7/8/10/11 close to 1x9 transceiver.

DC Coupling inside

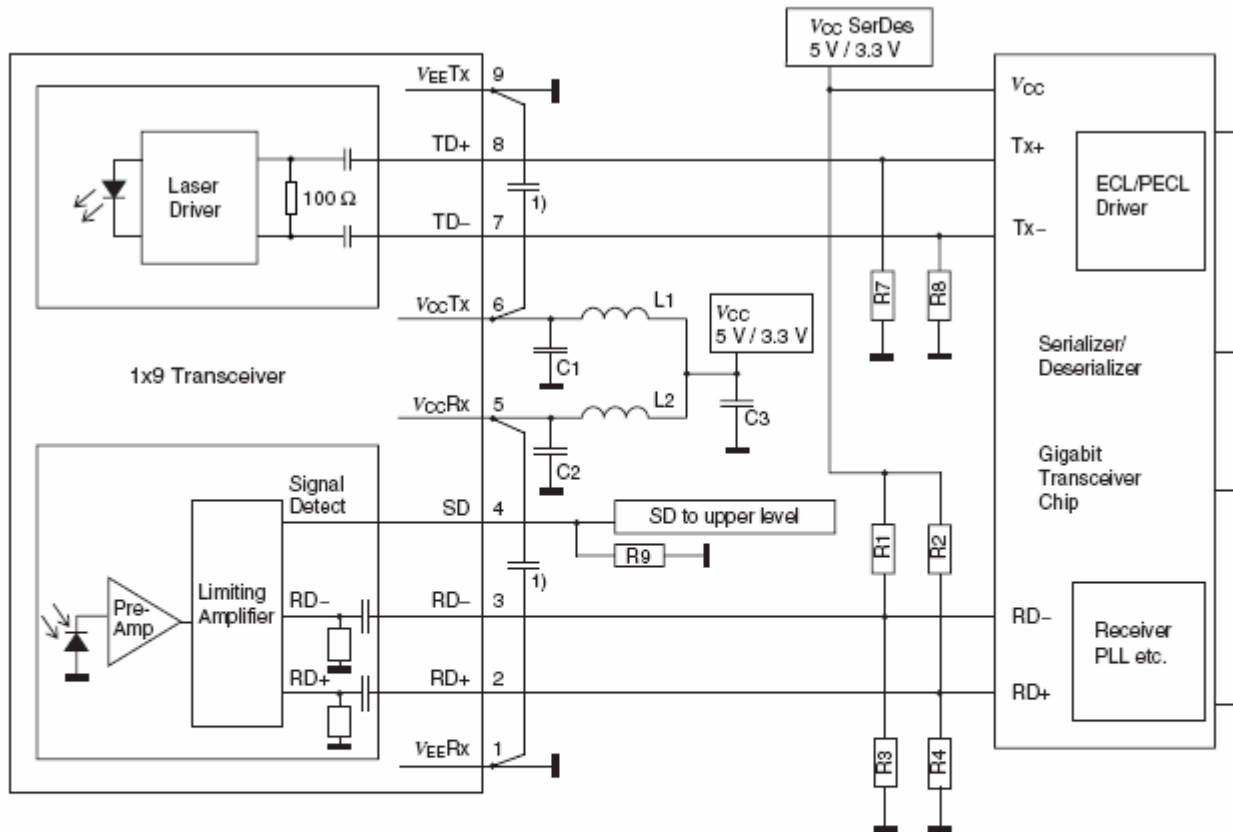

- C1/2/3 = 4.7 μF
- L1/2 = 1 μH
- R1/2/3/4 = Depends on SerDes chip used
- R7/8 = Biasing (depends on SerDes chip)
- R9 = open (5 V/3.3 V TTL)
- = 510 Ω (5 V PECL)
- = 270 Ω (3.3 V PECL)

Place R1/2/3/4/7/8 close to SerDes chip.
Place R5/6 close to 1x9 transceiver.

AC Coupling inside

Package Outline (Unit: mm)

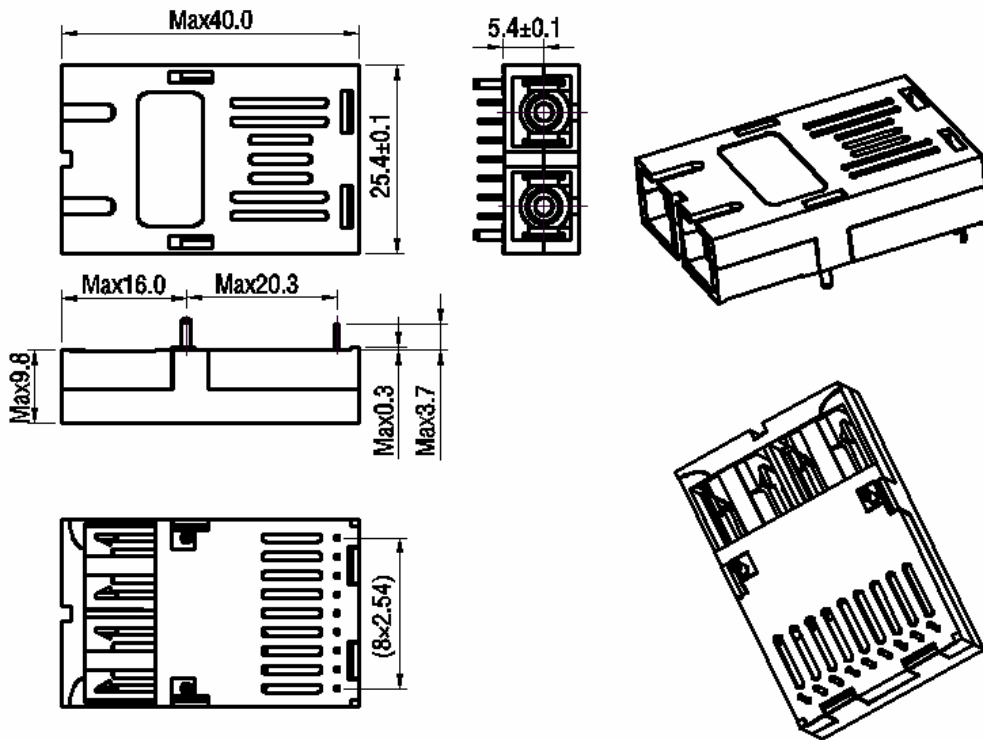

Class 1 Labels

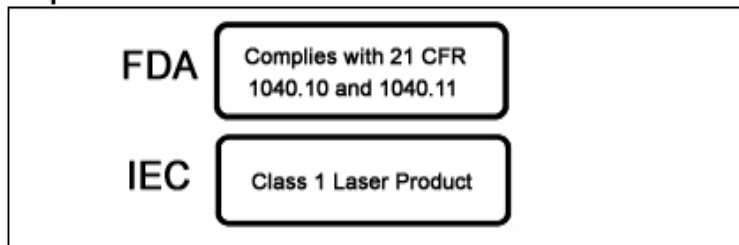

Laser Emission Data

Wavelength	850nm
Total output power (as defined by FDA: 7 mm aperture at 20 cm distance)	<0.076mW
Total output power (as defined by IEC: 7 mm aperture at 10 cm distance)	<0.778mW
Beam divergence	12°

Laser Emission

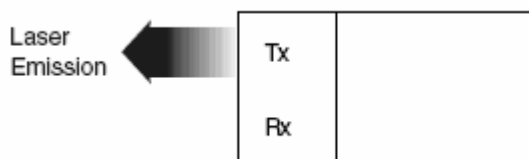

Obtaining Document

You can visit our website:

<http://www.eoptolink.com>

Or contact Eoptolink Technology Inc., Ltd. listed at the end of the documentation to get the latest documentation.

Revision History

Revision	Initiated	Reviewed	Approved	Revision History	Release Date
V2.a	Tim.Liang	Kelly.Cao	Richard.Huang	Released.	2007-3-27
V2.b	Philo.Chen	Kelly.Cao		Delete item7 in Note3, because it is not compliant with ROHS6.	June 17, 2009
V2.c	Cathy.Chen			Updated PN and change logo.	November 11, 2010

Notice:

Eoptolink reserves the right to make changes or discontinue any product or service identified in this publication, without notice, in order to improve design and/or performance. Applications that are described herein for any of the products are for illustrative purposes only. Eoptolink makes no representation or warranty that such applications will be suitable for the specified use without further testing or modification.

Contact:

Add: Floor 5 Building 2 No. 21 Gaopeng Avenue High-Tech District CHENGDU, SICHUAN 610041

P.R. CHINA

Tel: (+86) 028-85124308 ext 816 & 809 & 808

Fax: (+86) 028-85121912

Postal: 610041

E-mail: sales@eoptolink.com

<http://www.eoptolink.com>

Eoptolink