

## EOLP-8560-02

**850nm SFP+ single-Mode Transceiver, With Diagnostic Monitoring**  
**Multi-Rated up to 6.25Gbps CPRI/OBSAI MM SFP+ Transceiver**  
**RoHS 6 Compliant**

### Features

- ◆ Operating data rate up to 6.25Gbps
- ◆ CPRI/OBSAI Compatible Optical Interface
- ◆ 850nm VCSEL Transmitter
- ◆ Distance up to 300m with MMF
- ◆ Single 3.3V Power supply and TTL Logic Interface
- ◆ Duplex LC Connector Interface, Hot Pluggable
- ◆ Compliant with MSA SFP+ Specification SFF-8431
- ◆ Operating Case Temperature  
 Standard: -10°C~+70°C  
 Industrial: -40°C~+85°C



### Applications

- ◆ Radio Base Station
- ◆ OBSAI rates 6.144Gb/s, 3.072Gb/s, and 1.563Gb/s
- ◆ CPRI rates 4.9152Gb/s, 2.4576Gb/s, and 1.2288Gb/s

### Ordering information

Part No.	Data Rate	Laser	Fiber Type	Distance	Optical Interface	DDMI
EOLP-8560-02	Up to 6.25Gbps	850nm VCSEL	MMF	Up to 300m	LC	YES

### Regulatory Compliance

Feature	Standard	Performance
Electrostatic Discharge (ESD) to the Electrical Pins	MIL-STD-883G Method 3015.7	Class 1C (>1000 V)

Electrostatic Discharge to the enclosure	EN 55024:1998+A1+A2 IEC-61000-4-2 GR-1089-CORE	Compliant with standards
Electromagnetic Interference (EMI)	FCC Part 15 Class B EN55022:2006 CISPR 22B :2006 VCCI Class B	Compliant with standards Noise frequency range: 30 MHz to 6 GHz. Good system EMI design practice required to achieve Class B margins. System margins depend on customer host board and chassis design.
Immunity	EN 55024:1998+A1+A2 IEC 61000-4-3	Compliant with standards. 1kHz sine-wave, 80% AM, from 80-MHz to 1 GHz. No effect on transmitter/receiver performance is detectable between these limits.
Laser Eye Safety	FDA 21CFR 1040.10 and 1040.11 EN (IEC) 60825-1:2007 EN (IEC) 60825-2:2004+A1	CDRH compliant and Class I laser product. TüV Certificate No. 50135086
Component Recognition	UL and CUL EN60950-1:2006	UL file E317337 TüV Certificate No. 50135086 (CB scheme)
RoHS6	2002/95/EC 4.1&4.2 2005/747/EC 5&7&13	Compliant with standards <sup>*note2</sup>

Note 1: For update of the equipments and strict control of raw materials, EOPTOLINK has the ability to supply the customized products since Jan 1st, 2007, which meets the requirements of RoHS6 (Restrictions on use of certain Hazardous Substances) of European Union.

In light of item 5 in RoHS exemption list of RoHS Directive 2002/95/EC, Item 5: Lead in glass of cathode ray tubes, electronic components and fluorescent tubes.

In light of item 13 in RoHS exemption list of RoHS Directive 2005/747/EC, Item13: Lead and cadmium in optical and filter glass. The three exemptions are being concerned for Eoptolink's transceivers, because Eoptolink's transceivers use glass, which may contain Pb, for components such as lenses, windows, isolators, and other electronic components.

## Product Description

The EOLP-8560-02 series multi-mode transceiver is SFP+ module for duplex optical data communications such as OBSAI and CPRI. It is with the SFP+ 20-pin connector to allow hot plug capability. Digital diagnostic functions are available via an I<sup>2</sup>C. This module is designed for multi-mode fiber and operates at a nominal wavelength of 850 nm.

The transmitter section uses a Vertical Cavity Surface Emitted Laser (VCSEL) and is a Class 1

laser compliant according to International Safety Standard IEC 60825. The receiver section uses an integrated GaAs detector preamplifier (IDP) mounted in an optical header and a limiting post-amplifier IC.

## Absolute Maximum Ratings

Parameter	Symbol	Min.	Max.	Unit
Storage Temperature	$T_s$	-40	+85	°C
Supply Voltage	$V_{CC}$	-0.5	3.6	V
Input Voltage	$V_{in}$	-0.5	$V_{CC}$	V
Output Current	$I_o$	-	50	mA

## Recommended Operating Conditions

Parameter	Symbol	Min.	Typical	Max.	Unit	
Operating Case Temperature	$T_A$	EOLP-8560-02	-10		+70	°C
		EOLP-8560-02				
Power Supply Voltage	$V_{CC}$	3.15	3.3	3.45	V	
Power Supply Current	$I_{CC}$			300	mA	
Surge Current	$I_{Surge}$			+30	mA	
Baud Rate		1		6.25	Gbps	

## Performance Specifications - Electrical

Parameter	Symbol	Min.	Typ.	Max	Unit	Notes
<b>Transmitter</b>						
CML Inputs(Differential)	$V_{in}$	150		1200	mVpp	AC coupled inputs
Input Impedance (Differential)	$Z_{in}$	85	100	115	ohms	$R_{in} > 100 \text{ kohms @ DC}$
Tx_DISABLE Input Voltage - High		2		$V_{CC}+0.3$	V	
Tx_DISABLE Input Voltage - Low		0		0.8	V	
Tx_FAULT Output Voltage -- High		2		$V_{CC}+0.3$	V	$I_o = 400\mu\text{A}; \text{Host } V_{CC}$
Tx_FAULT Output Voltage -- Low		0		0.8	V	$I_o = -4.0\text{mA}$
<b>Receiver</b>						
CML Outputs (Differential)	$V_{out}$	350		700	mVpp	AC coupled outputs
Output Impedance (Differential)	$Z_{out}$	85	100	115	ohms	

Rx_LOS Output Voltage - High		2		V <sub>CC</sub> +0.3	V	I <sub>o</sub> = 400µA; Host V <sub>CC</sub>
Rx_LOS Output Voltage - Low		0		0.8	V	I <sub>o</sub> = -4.0mA
MOD_DEF (0:2)	VoH	2.5			V	With Serial ID
	VoL	0		0.5	V	

### Optical and Electrical Characteristics

Parameter	Symbol	Min.	Typical	Max.	Unit
50 / 125 µm MMF			300		m
Data Rate		1		6.25	Gbps
<b>Transmitter</b>					
Centre Wavelength	$\lambda_C$	840	850	860	nm
Spectral Width (RMS)	$\Delta\lambda$			0.45	nm
Average Output Power	P <sub>out</sub>	-6		-1	dBm
Extinction Ratio	ER	3.0	5.0		dB
Output Optical Eye		IEEE 802.3-2005 Compliant			
Transmitter Dispersion Penalty	TDP			3.9	dB
Input Differential Impedance	Z <sub>IN</sub>	90	100	110	Ω
TX Disable	Disable		2.0	V <sub>CC</sub> +0.3	V
	Enable		0	0.8	
TX_Fault	Fault		2.0	V <sub>CC</sub> +0.3	V
	Normal		0	0.8	
TX_Disable Assert Time	t <sub>off</sub>			10	µs
TX_DISABLE Negate Time	t <sub>on</sub>	-	-	1	ms
TX_BISABLE time to start reset	t <sub>reset</sub>	10	-	-	us
Time to initialize, include reset of TX_FAULT	t <sub>init</sub>	-	-	300	ms
TX_FAULT from fault to assertion	t <sub>fault</sub>	-	-	100	us
Total Jitter	TJ	-	-	0.28	UI(p-p)
Data Dependant Jitter	DDJ	-	-	0.1	UI(p-p)
Uncorrelated Jitter	UJ	-	-	0.023	RMS
<b>Receiver</b>					
Centre Wavelength	$\lambda_C$	840	850	860	nm
Receiver Sensitivity <sup>2</sup>	P <sub>min</sub>			-12	dBm
Output Differential Impedance	R <sub>IN</sub>	90	100	110	Ω
Receiver Overload <sup>2</sup>	P <sub>max</sub>	-1			dBm
Optical Return Loss	ORL			-12	dB
LOS De-Assert	LOS <sub>D</sub>			-12	dBm
LOS Assert	LOS <sub>A</sub>	-25			dBm
LOS Hysteresis		0.5			dB
LOS	High		2.0	V <sub>CC</sub> +0.3	V

	Low		0		0.8	
--	-----	--	---	--	-----	--

Note 2: Measured with a PRBS 2<sup>31</sup> -1 test pattern, BER ≤ 10<sup>-12</sup>

### SFP+ Transceiver Electrical Pad Layout

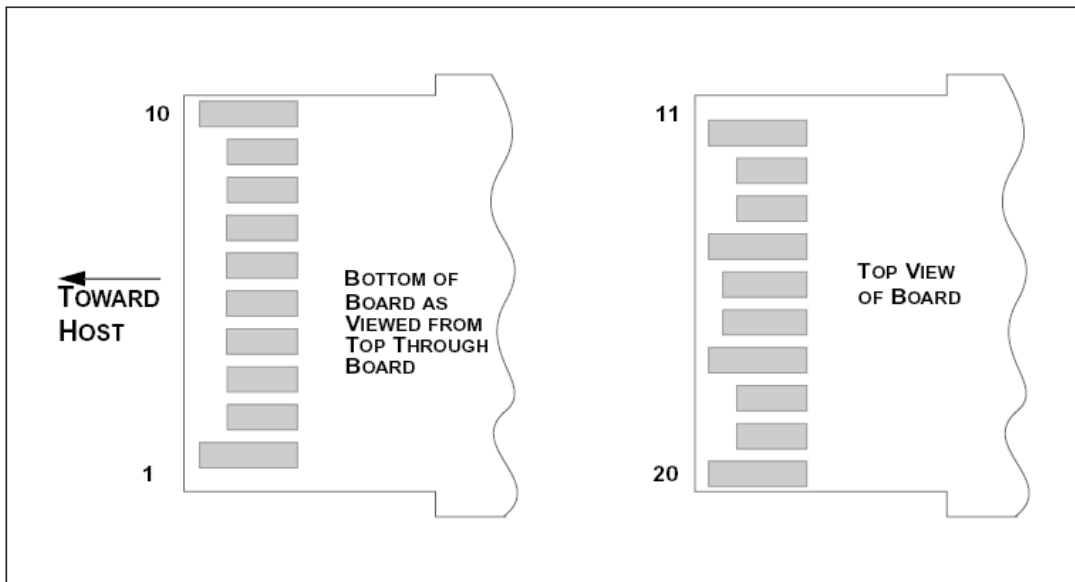
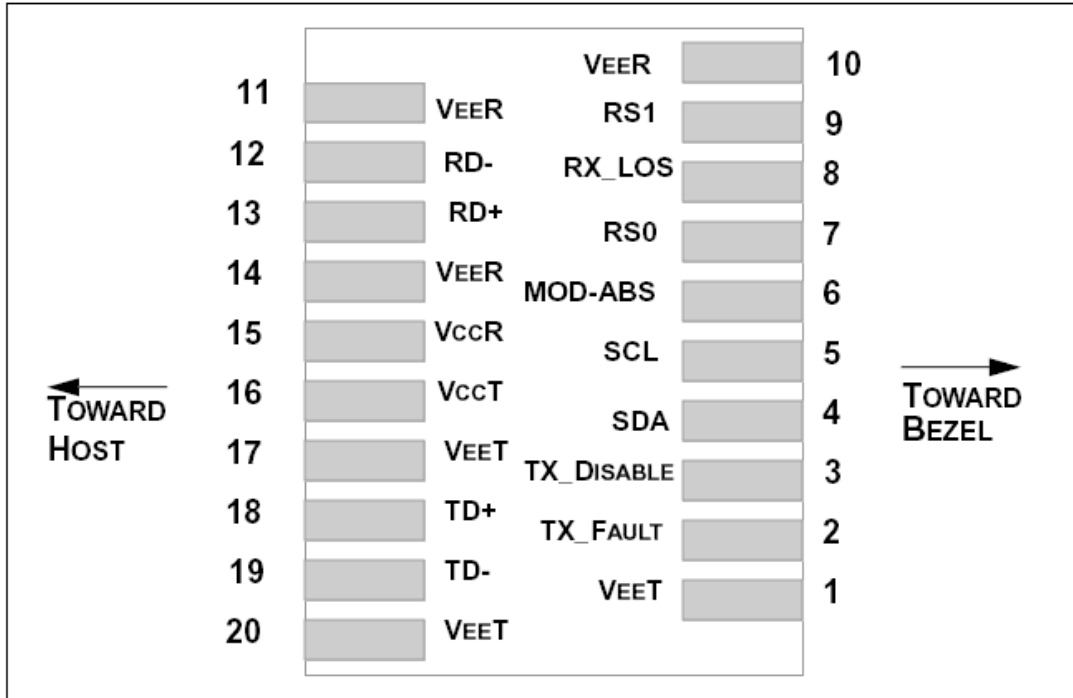

### Pin Function Definitions

Pin Num.	Name	Function	Plug Seq.	Notes
1	VeeT	Transmitter Ground	1	
2	TX Fault	Transmitter Fault Indication	3	Note 1
3	TX Disable	Transmitter Disable	3	Note 2, Module disables on high or open
4	SDA	Module Definition 2	3	Note 3, Data line for Serial ID.
5	SCL	Module Definition 1	3	Note 3, Clock line for Serial ID.
6	MOD-ABS	Module Definition 0	3	Note 3
7	RS0	RX Rate Select (LVTTL).	3	This pin has an internal 30k pull down to ground. A signal on this pin will not affect module performance.
8	LOS	Loss of Signal	3	Note 4
9	RS1	TX Rate Select (LVTTL).	1	This pin has an internal 30k pull down to ground. A signal on this pin will not affect module performance.
10	VeeR	Receiver Ground	1	Note 5
11	VeeR	Receiver Ground	1	Note 5
12	RD-	Inv. Received Data Out	3	Note 6
13	RD+	Received Data Out	3	Note 6
14	VeeR	Receiver Ground	1	Note 5
15	VccR	Receiver Power	2	3.3 ± 5%, Note 7
16	VccT	Transmitter Power	2	3.3 ± 5%, Note 7
17	VeeT	Transmitter Ground	1	Note 5
18	TD+	Transmit Data In	3	Note 8
19	TD-	Inv. Transmit Data In	3	Note 8
20	VeeT	Transmitter Ground	1	Note 5

### Notes:

1) TX Fault is an open collector/drain output, which should be pulled up with a 4.7K – 10KΩ resistor on the host board. Pull up voltage between 2.0V and VccT, R+0.3V. When high, output indicates a laser fault of some kind. Low indicates normal operation. In the low state, the output will be pulled to < 0.8V.

2) TX disable is an input that is used to shut down the transmitter optical output. It is pulled up within the module with a 4.7~10 K Ω resistor. Its states are:

Low (0 – 0.8V): Transmitter on

(>0.8, < 2.0V): Undefined

High (2.0 – 3.465V): Transmitter Disabled

Open: Transmitter Disabled

3) Modulation Absent, connected to VEET or VEER in the module.

4) LOS (Loss of Signal) is an open collector/drain output, which should be pulled up with a 4.7K – 10KΩ resistor. Pull up voltage between 2.0V and VccT, R+0.3V. When high, this output indicates the received optical power is below the worst-case receiver sensitivity (as defined by the standard in use). Low indicates normal operation. In the low state, the output will be pulled to < 0.8V.

5) VeeR and VeeT may be internally connected within the SFP+ module.

6) RD-/+: These are the differential receiver outputs. They are AC coupled 100Ω differential lines which should be terminated with 100Ω (differential) at the user SERDES. The AC coupling is done inside the module and is thus not required on the host board. The voltage swing on these lines will be between 370 and 700 mV differential (185 –350 mV single ended) when properly terminated.

7) VccR and VccT are the receiver and transmitter power supplies. They are defined as 3.3V ±5% at the SFP+ connector pin. Maximum supply current is 300mA. Inductors with DC resistance of less than 1 ohm should be used in order to maintain the required voltage at the SFP+ input pin with 3.3V supply voltage. When the recommended supply-filtering network is used, hot plugging of the SFP+ transceiver module will result in an inrush current of no more than 30mA greater than the steady state value. VccR and VccT may be internally connected within the SFP+ transceiver module.

8) TD-/+: These are the differential transmitter inputs. They are AC-coupled, differential lines with 100Ω differential termination inside the module. The AC coupling is done inside the module and is thus not required on the host board. The inputs will accept differential swings of 150 – 1200 mV (75 – 600mV single-ended), though it is recommended that values between 150 and 1200 mV differential (75 – 600mV single-ended) be used for best EMI performance.

## EEPROM

The serial interface uses the 2-wire serial CMOS EEPROM protocol defined for the ATMEL AT24C02/04 family of components. When the serial protocol is activated, the host generates the serial clock signal (SCL). The positive edge clocks data into those segments of the EEPROM that are not writing protected within the SFP+ transceiver. The negative edge clocks data from the SFP+ transceiver. The serial data signal (SDA) is bi-directional for serial data transfer. The host uses SDA in conjunction with SCL to mark the start and end of serial protocol activation. The memories are organized as a series of 8-bit data words that can be addressed individually or sequentially.

The Module provides diagnostic information about the present operating conditions. The transceiver generates this diagnostic data by digitization of internal analog signals. Calibration and alarm/warning threshold data is written during device manufacture. Received power monitoring, transmitted power monitoring, bias current monitoring, supply voltage monitoring and temperature monitoring all are implemented. If the module is defined as external calibrated, the diagnostic data are raw A/D values and must be converted to real world units using calibration constants stored in

EEPROM locations 56 – 95 at wire serial bus address A2H. The digital diagnostic memory map specific data field define as following .For detail EEPROM information, please refer to the related document of SFF 8472 Rev 10.3.

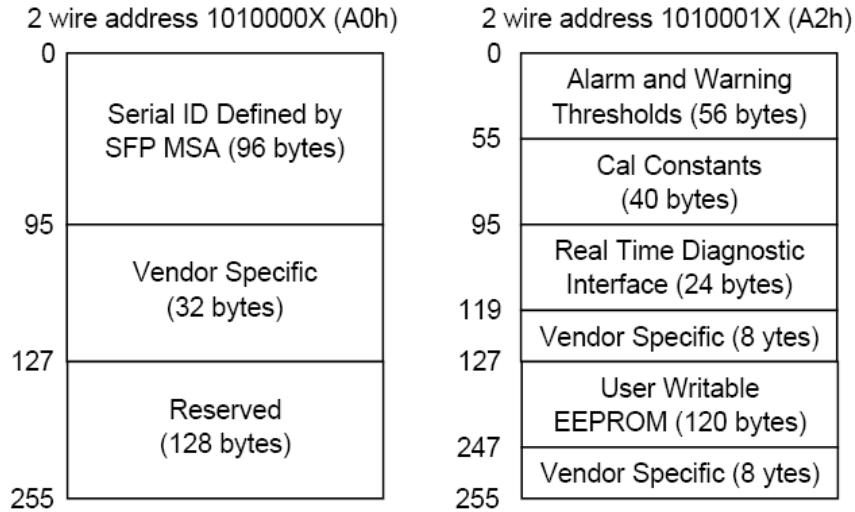

Recommend Circuit Schematic

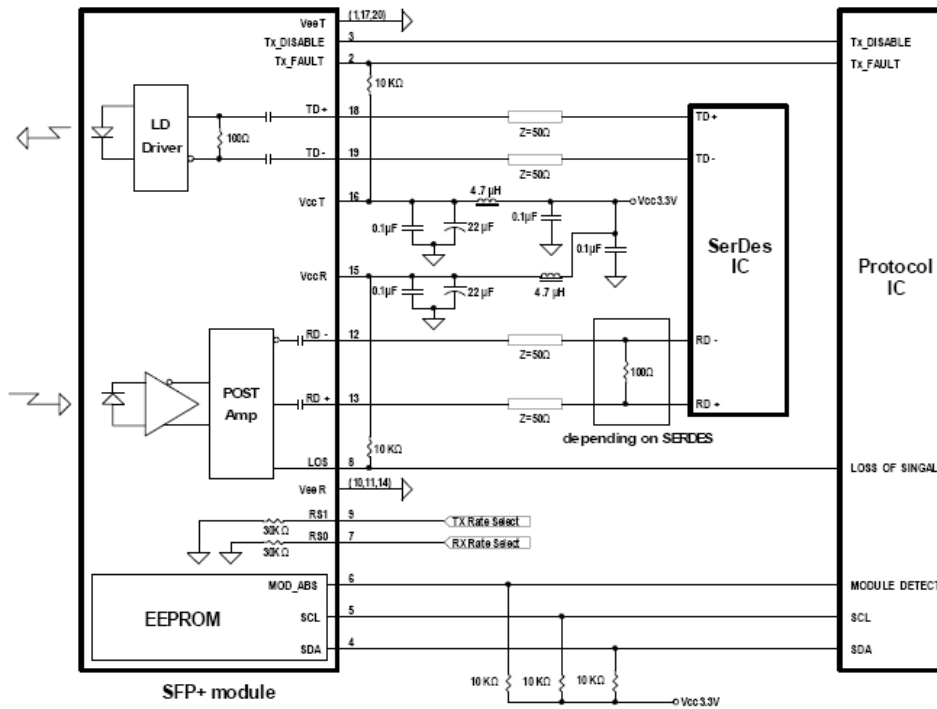

## Mechanical Specifications

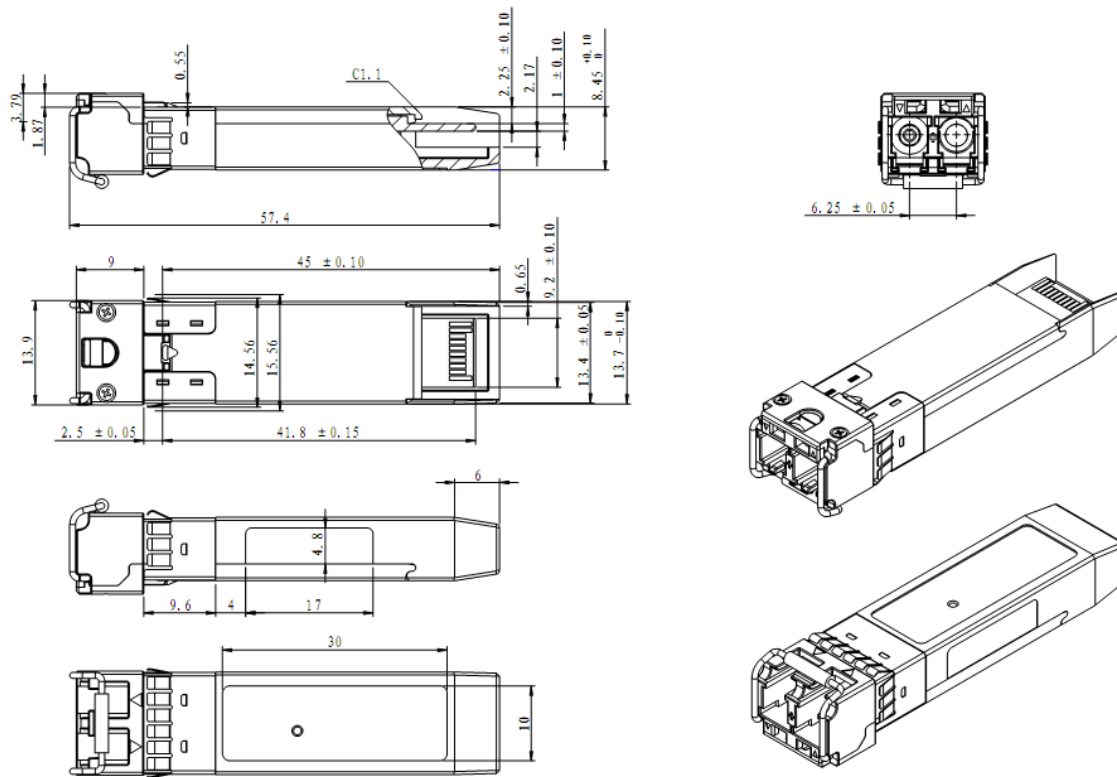

## Eye Safety

This single-mode transceiver is a Class 1 laser product. It complies with IEC-60825 and FDA 21 CFR 1040.10 and 1040.11. The transceiver must be operated within the specified temperature and voltage limits. The optical ports of the module shall be terminated with an optical connector or with a dust plug.

## Obtaining Document

You can visit our website:

<http://www.eoptolink.com>

Or contact Eoptolink Technology Inc., Ltd. listed at the end of the documentation to get the latest documents.

## Revision History

Revision	Initiate	Review	Approve	Revision History	Release Date
V1.a	Cathy			Released	2009-12-15

**Notice:**

Eoptolink reserves the right to make changes to or discontinue any optical link product or service identified in this publication, without notice, in order to improve design and/or performance. Applications that are described herein for any of the optical link products are for illustrative purposes only. Eoptolink makes no representation or warranty that such applications will be suitable for the specified use without further testing or modification.

**Contact:**

Add: Floor 5 Building 2 No. 21 Gaopeng Avenue High-Tech District CHENGDU, SICHUAN 610041  
P.R. CHINA

Tel: (+86) 028-85124308 ext 808 & 809 & 816 & 828

Fax: (+86) 028-85121912

Postal: 610041

E-mail: [sales@eoptolink.com](mailto:sales@eoptolink.com)

<http://www.eoptolink.com>