

EOLF-BI1X24-X Series

Single-Mode 2.5Gbps
 SC/LC/Pigtail Single-Fiber SFF
 Transceiver
 RoHS6 Compliant



Features

- ◆ Single-Mode Transceiver
- ◆ Support 2.5Gbps Data Links
- ◆ 5km with 9/125μm SMF
- 10km with 9/125μm SMF
- 20km with 9/125μm SMF
- 40km with 9/125μm SMF
- ◆ Single 3.3V Power Supply and TTL Logic Interface
- ◆ SC/LC/Pigtail Connector Interface
- ◆ Class 1 FDA and IEC60825-1 Laser Safety Compliant
- ◆ Operating Case Temperature Standard: 0°C~+70°C
 Industrial: -40°C~+85°C
- ◆ Compliant with SFF MSA Specification
- ◆ Compliant with SFF 8472 MSA

Applications

- ◆ SONET/SDH Links
- ◆ Gigabit Ethernet Links
- ◆ Fiber Channel Links
- ◆ Other Optical Link

Ordering information

Part No.	Data Rate	λ(nm)	Interface	Distance	Form	Temp.	DDMI
EOLF-BI1324-5	100M~2.5Gbps	1310	SC	5km	2x5	Standard	NO
EOLF-BI1524-5	100M~2.5Gbps	1550	SC	5km	2x5	Standard	NO
EOLF-BI1324-10	100M~2.5Gbps	1310	SC	10km	2x5	Standard	NO
EOLF-BI1524-10	100M~2.5Gbps	1550	SC	10km	2x5	Standard	NO
EOLF-BI1324-20	100M~2.5Gbps	1310	SC	20km	2x5	Standard	NO
EOLF-BI1524-20	100M~2.5Gbps	1550	SC	20km	2x5	Standard	NO
EOLF-BI1324-40	100M~2.5Gbps	1310	SC	40km	2x5	Standard	NO
EOLF-BI1524-40	100M~2.5Gbps	1550	SC	40km	2x5	Standard	NO

Note1: The above table lists the standard version only. For other order information, please refer the following

nomenclature and consult EOPTOLINK.

Nomenclature

EOL□- □□□-□□□□□□□□

A B C D E F G H I J K L

Code	Parameter	Detailed description				
A	F					
B	Blank	BI				
C	λ	13=1310nm	15=1550nm	16=CWDM		
D	Data Rate	03=155M, 06=2.5G, 10=100M~1000M, 12=2.5G, 24=2.5G, 26=2.67G, 30=3.125G, 48=4.25G, R=request				
E	Distance	02=850nm, MMF	XM=Blank~9Km, FP, MM F, (Blank=1Km, X=2~9)	XX=XX Km (SMF, X=0~9)	A=100Km	B=120Km
F	DDM	Blank=Without DDM		D=With DDM		
G	CWDM TX λ	A=1270, B=1290,, R=1610				
H	CWDM RX λ	A=1270, B=1290,, R=1610				
I	Form	Blank=2x5	A=2x10	6=2x6	7=2x7	
J	Temperature	Blank=0~70		I=-40~85		
K	Connector	Blank=SC	L=LC	P=Pigtail/SC		
L	Input/output & SD	Blank=Input: DC; Output: DC; SD-TTL (FC/GBE/2FC/OC48)		Blank=Input: DC; Output: DC; SD-PECL(OC-3/STM-4)		
		1=Input: AC; Output: AC; SD-TTL (FC/GBE/2FC/OC48)		1=Input: AC; Output: AC; SD-PECL (OC-3/STM-4)		
		2=Input: AC; Output: DC; SD-TTL (FC/GBE/2FC/OC48)		2=Input: AC; Output: DC; SD-PECL (OC-3/STM-4)		
		3=Input: DC; Output: AC; SD-TTL (FC/GBE/2FC/OC48)		3=Input: DC; Output: AC; SD-PECL (OC-3/STM-4)		

Regulatory Compliance

Feature	Standard	Performance
Electrostatic Discharge (ESD) to the Electrical Pins	MIL-STD-883G Method 3015.7	Class 1C (>1000 V)
Electrostatic Discharge to the enclosure	EN 55024:1998+A1+A2 IEC-61000-4-2 GR-1089-CORE	Compliant with standards
Electromagnetic Interference (EMI)	FCC Part 15 Class B EN55022:2006 CISPR 22B :2006 VCCI Class B	Compliant with standards Noise frequency range: 30MHz to 6GHz. Good system EMI design practice required

		to achieve Class B margins. System margins are dependent on customer host board and chassis design.
Immunity	EN 55024:1998+A1+A2 IEC 61000-4-3	Compliant with standards. 1KHz sine-wave, 80% AM, from 80MHz to 1GHz. No effect on transmitter/receiver performance is detectable between these limits.
Laser Eye Safety	FDA 21CFR 1040.10 and 1040.11 EN (IEC) 60825-1:2007 EN (IEC) 60825-2:2004+A1	CDRH compliant and Class I laser product. TüV Certificate No. 50135086
Component Recognition	UL and CUL EN60950-1:2006	UL File E317337 TüV Certificate No. 50135086 (CB scheme)
RoHS6	2002/95/EC 4.1&4.2 2005/747/EC 5&7&13	Compliant with standards ^{*note3}

Note2: For update of the equipments and strict control of raw materials, EOPTOLINK has the ability to supply the customized products since Jan 1st, 2007, which meet the requirements of RoHS6 (Restrictions on use of certain Hazardous Substances) of European Union.

In light of item 5 in RoHS exemption list of RoHS Directive 2002/95/EC, Item 5: Lead in glass of cathode ray tubes, electronic components and fluorescent tubes.

In light of item 13 in RoHS exemption list of RoHS Directive 2005/747/EC, Item 13: Lead and cadmium in optical and filter glass. The three exemptions are being concerned for Eoptolink's transceivers, because Eoptolink's transceivers use glass, which may contain Pb, for components such as lenses, windows, isolators, and other electronic components.

Product Description

The EOLF-BI1X24-X series is small form factor pluggable module for SONET/SDH application, single fiber applications by using 1310nm/1550nm transmitter and 1550nm/1310nm receiver. It is with the SFF 20-pin connector to allow hot plug capability.

The transmitter section uses a multiple quantum well laser and is a class 1 laser compliant according to International Safety Standard IEC 60825. The receiver section uses an integrated detector preamplifier (IDP) mounted in an optical header and a limiting post-amplifier IC.

Absolute Maximum Ratings^{*Note3}

Parameter	Symbol	Min.	Max.	Unit
Storage Temperature	Ts	-40	+85	°C
Supply Voltage	Vcc	-0.5	3.6	V
Operating Relative Humidity		-	95	%

*Note3: Exceeding any one of these values may destroy the device permanently.

Recommended Operating Conditions

Parameter	Symbol	Min.	Typical	Max.	Unit	
Operating Case Temperature	T _A	EOLF-BI1X24-X	0		+70	°C
		EOLF-BI1X24-XI	-40		+85	
Power Supply Voltage	V _{cc}	3.15	3.3	3.45	V	
Power Supply Current	I _{cc}			300	mA	
Data Rate	OC-48/STM-16		2.5		Gbps	
	GBE		1.25		Gbps	
	FC		1.063		Gbps	

Performance Specifications - Electrical

Parameter	Symbol	Min.	Typ.	Max	Unit	Notes
Transmitter						
LVPECL Inputs(Differential)	V _{in}	400		2000	mVpp	AC coupled inputs*(note5)
Input Impedance (Differential)	Z _{in}	85	100	115	ohms	R _{in} > 100 kohms @ DC
TX_Dis	Disable	2		V _{cc} +0.3	V	
	Enable	0		0.8		
TX_FAULT	Fault	2		V _{cc} +0.3	V	
	Normal	0		0.5		
Receiver						
LVPECL Outputs (Differential)	V _{out}	400		2000	mVpp	AC coupled outputs*(note5)
Output Impedance (Differential)	Z _{out}	85	100	115	ohms	
RX_LOS	LOS	2		V _{cc} +0.3	V	
	Normal	0		0.8	V	
MOD_DEF (0:2)	VoH	2.5			V	With Serial ID
	VoL	0		0.5	V	

Optical and Electrical Characteristics

(EOLF-BI1X24-5, 1310nm FP / PIN & 1550nm DFB / PIN, 5km)

Parameter	Symbol	Min.	Typical	Max.	Unit
9µm Core Diameter SMF	L		5		km
Data Rate			2.5		Gbps
Transmitter					
Center Wavelength, EOLF-BI1324-5	λ _c	1260	1310	1360	nm

Center Wavelength, EOLF-BI1524-5		1530	1550	1570	
Spectral Width (RMS), EOLF-BI1324-5	$\Delta\lambda$			4	nm
Spectral Width (-20dB), EOLF-BI1524-5				1	
Average Output Power ^{*(note3)}	P _{out}	-9		-3	dBm
Extinction Ratio ^{*(note4)}	ER	8.2			dB
Rise/Fall Time(20%~80%)	tr/tf			2	ns
Output Optical Eye ^{*(note4)}	IUT-T G.957 Compliant ^{*(note7)}				
TX_Disable Assert Time	t _{off}			10	us
P _{out} @TX Disable Asserted	P _{out}			-45	dBm
Receiver					
Center Wavelength, EOLF-BI1324-5	λ_c	1480	1550	1600	nm
Center Wavelength, EOLF-BI1524-5		1260	1310	1360	
Receiver Sensitivity ^{*(note6)}	P _{min}			-18	dBm
Receiver Overload	P _{max}	-3			dBm
LOS De-Assert	LOSD			-19	dBm
LOS Assert	LOSA	-32			dBm
LOS Hysteresis ^{*(note8)}		0.5			dB

(EOLF-BI1X24-20, 1310nm DFB / PIN & 1550nm DFB / PIN, 20km)

Parameter	Symbol	Min.	Typical	Max.	Unit
9μm Core Diameter SMF	L		20		km
Data Rate			2.5		Gbps
Transmitter					
Center Wavelength, EOLF-BI1324-20	λ_c	1260	1310	1360	nm
Center Wavelength, EOLF-BI1524-20		1530	1550	1570	
Spectral Width (-20dB)	$\Delta\lambda$			1	nm
Average Output Power ^{*(note3)}	P _{out}	-5		0	dBm
Extinction Ratio ^{*(note4)}	ER	8.2			dB
Rise/Fall Time(20%~80%)	tr/tf			2	ns
Output Optical Eye ^{*(note4)}	IUT-T G.957 Compliant ^{*(note7)}				
TX_Disable Assert Time	t _{off}			10	us
P _{out} @TX Disable Asserted	P _{out}			-45	dBm
Receiver					
Center Wavelength, EOLF-BI1324-20	λ_c	1480	1550	1600	nm
Center Wavelength, EOLF-BI1524-20		1260	1310	1360	
Receiver Sensitivity ^{*(note6)}	P _{min}		-19	-18	dBm
Receiver Overload	P _{max}	-3			dBm
LOS De-Assert	LOSD			-19	dBm
LOS Assert	LOSA	-32			dBm
LOS Hysteresis ^{*(note8)}		0.5			dB

(EOLF-BI1X24-40, 1310nm DFB / PIN & 1550nm DFB / PIN, 40km)

Parameter	Symbol	Min.	Typical	Max.	Unit
-----------	--------	------	---------	------	------

9μm Core Diameter SMF	L		40		km
Data Rate			2.5		Gbps
Transmitter					
Center Wavelength, EOLF-BI1324-40	λ_c	1260	1310	1360	nm
Center Wavelength, EOLF-BI1524-40		1530	1550	1570	
Spectral Width (-20dB)	$\Delta\lambda$			1	nm
Average Output Power ^{*(note3)} , EOLF-BI1324-40	P _{out}	0		4	dBm
Average Output Power ^{*(note3)} , EOLF-BI1524-40		-2		3	
Extinction Ratio ^{*(note4)}	ER	8.2			dB
Rise/Fall Time(20%~80%)	tr/tf			2	ns
Output Optical Eye ^{*(note4)}	IUT-T G.957 Compliant ^{*(note7)}				
TX_Disable Assert Time	t _{off}			10	us
P _{out} @TX Disable Asserted	P _{out}			-45	dBm
Receiver					
Center Wavelength, EOLF-BI1324-40	λ_c	1480	1550	1600	nm
Center Wavelength, EOLF-BI1524-40		1260	1310	1360	
Receiver Sensitivity ^{*(note6)}	P _{min}		-21	-20	dBm
Receiver Overload	P _{max}	-3			dBm
LOS De-Assert	LOSD			-21	dBm
LOS Assert	LOSA	-42			dBm
LOS Hysteresis ^{*(note8)}		0.5			dB

Note3: Output is coupled into a 9/125μm single-mode fiber.

Note4: Filtered, measured with a PRBS 2²³-1 test pattern @2.5Gbps

Note5: LVPECL logic, internally AC coupled.

Note6: Minimum average optical power measured at BER less than 1E-12, with a 2²³-1 PRBS and ER=9 dB.

Note7: Eye Pattern Mask

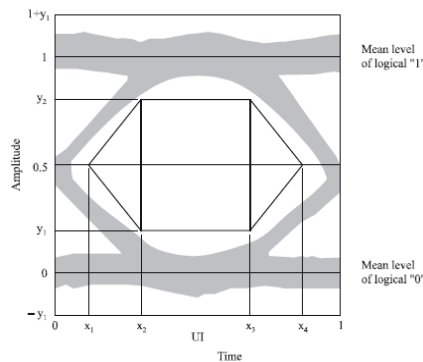

Note8: SD Hysteresis

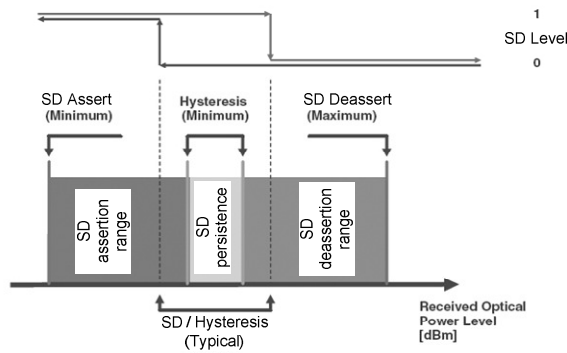

Functional Description of Transceiver

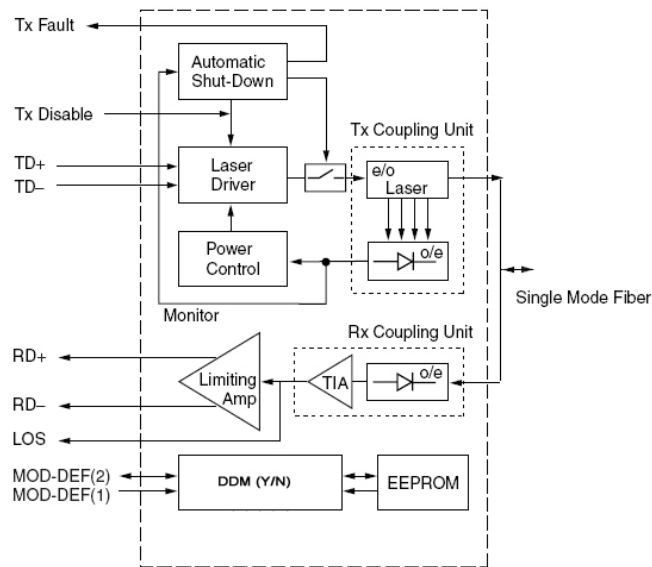

SFF Transceiver Electrical Pad Layout

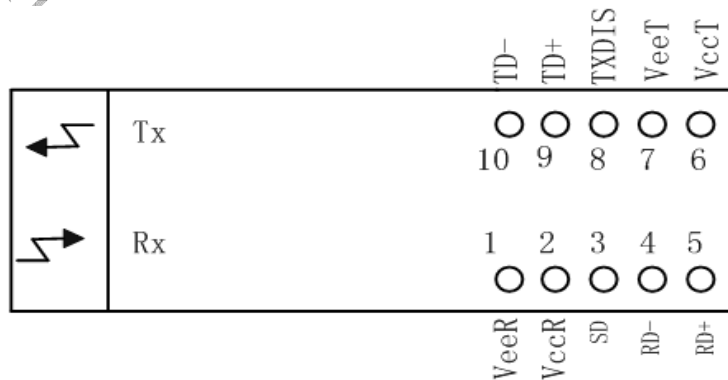

Case isolated from circuit ground.

Pin Function Definitions

Pin No.	Name	Function
	MS	Mounting Studs, Case isolated from circuit ground
1	VeeR	Receiver Signal Ground
2	VccR	3.3V DC power for receiver section
3	SD	Signal Detect Output (LVPECL) "1" - "Signal valid", "0" - "Lose of signal"
4	RD-	Received Data Out Bar (LVPECL), without termination inside
5	RD+	Received Data Out (LVPECL), without termination inside
6	VccT	3.3V DC power for transmitter section
7	VeeT	Transmitter Signal Ground
8	TXDIS	Transmitter Disable (LVTTL), "1" - Disable, "0" - Enable
9	TD+	Transmitter Data In (LVPECL), without termination inside
10	TD-	Transmitter Data In Bar (LVPECL), without termination inside

Recommend Circuit Schematic

AC/AC coupling

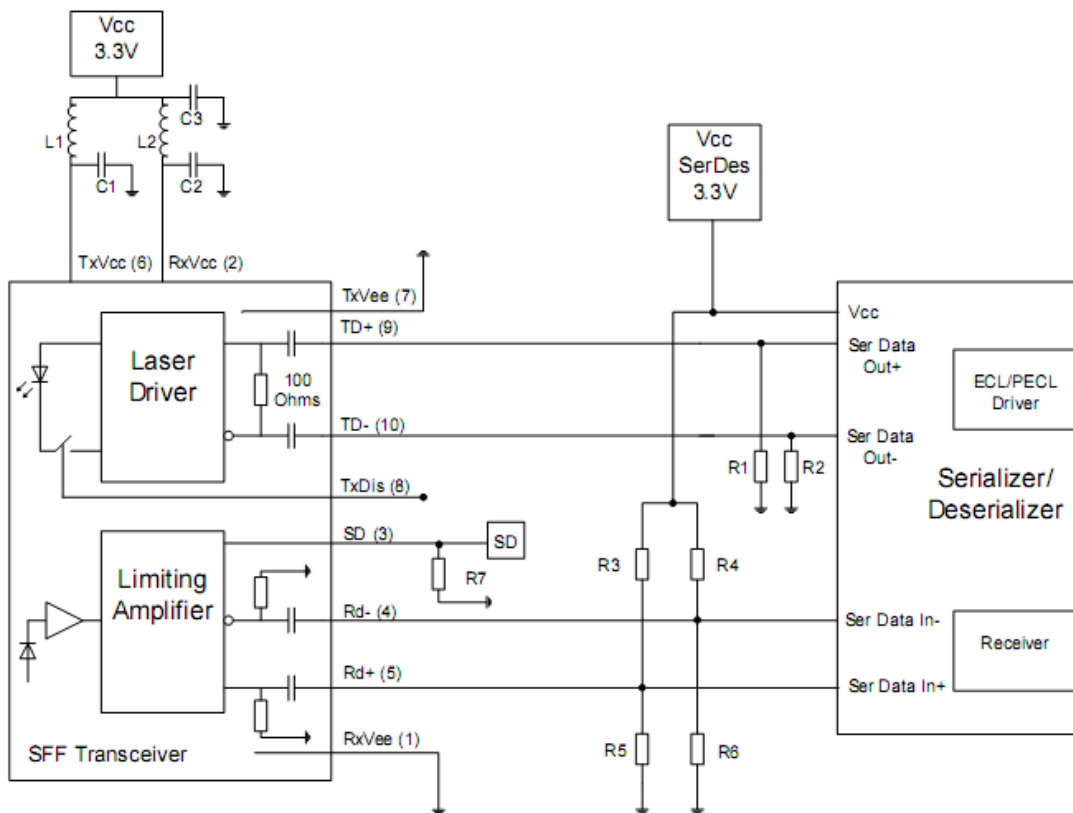

- L1, L2: 1...4.7 μ H
 - C1, C2, C3: 4.7...10 μ F
 - R1, R2: biasing of outputs depending on Serializer
 - R3, R4: 127 Ohms
 - R5, R6: 80 Ohms
 - R7: 510 Ohms for PECL signal detect, open for TTL
- Place R1/2/3/4/5/6 as close to SerDes chip as possible

DC/DC coupling

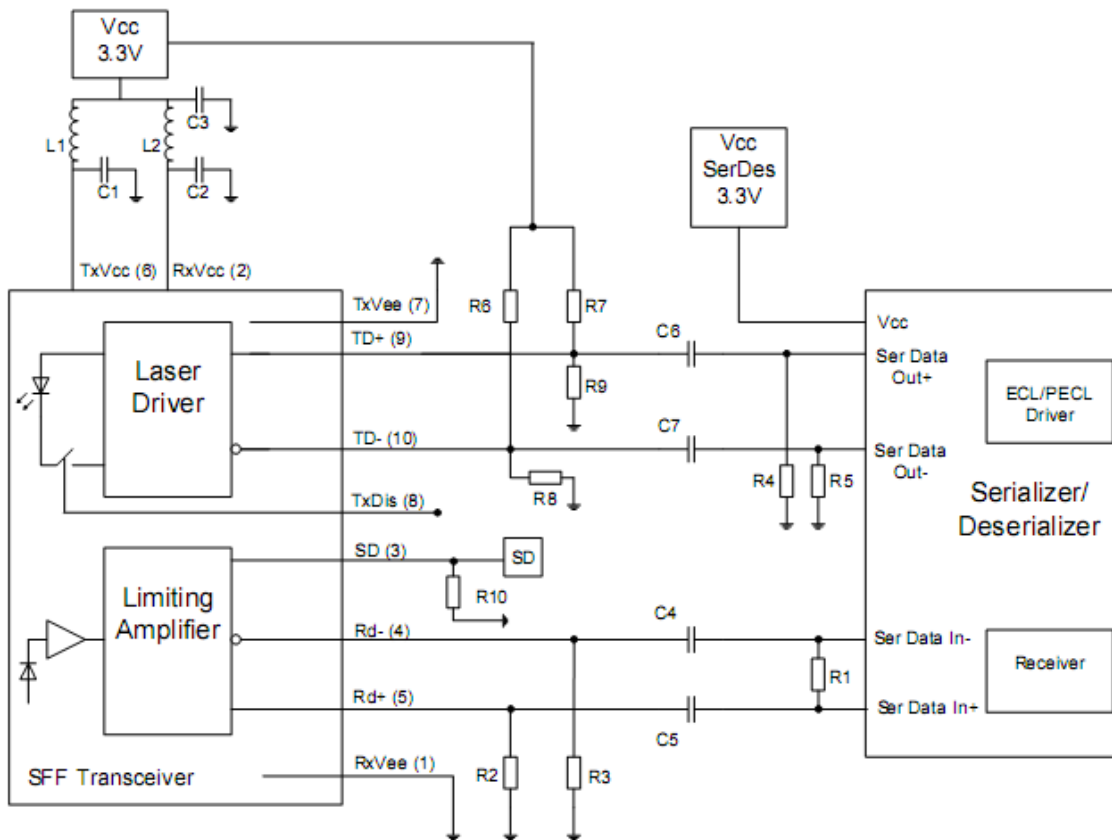

- L1, L2: 1...4.7 μ H
 - C1, C2, C3: 4.7...10 μ F
 - C4, C5, C6, C7: 100 nF
 - R1: 100 Ohms
 - R2, R3: 150 Ohms
 - R4, R5: biasing of outputs depending on Serializer
 - R6, R7: 127 Ohms
 - R8, R9: 80 Ohms
 - R10: 510 Ohms for PECL signal detect, open for TTL
- Place R1/4/5 as close to SerDes as possible
Place R2/3 as close to transceiver as possible

Mechanical Specifications*

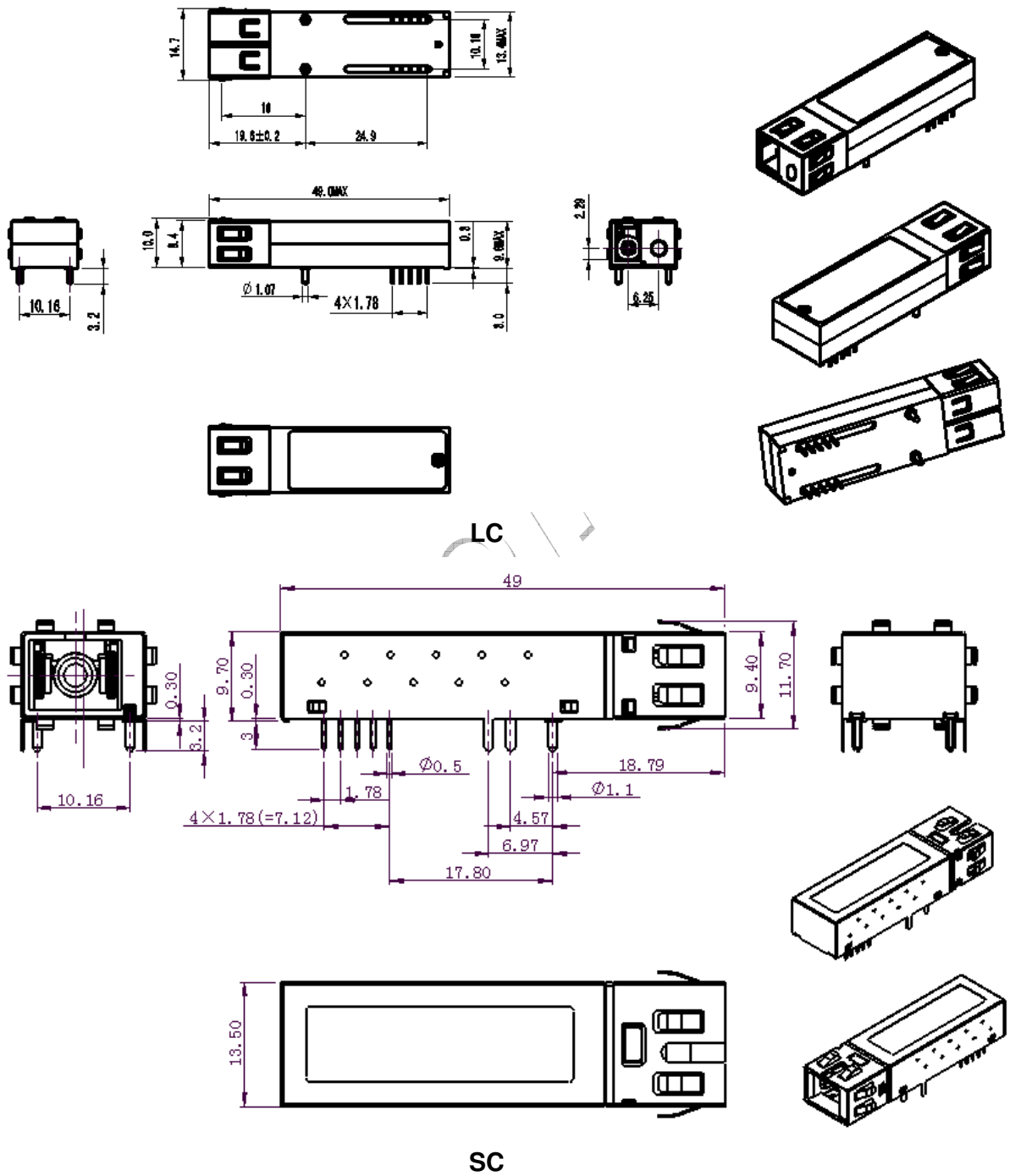

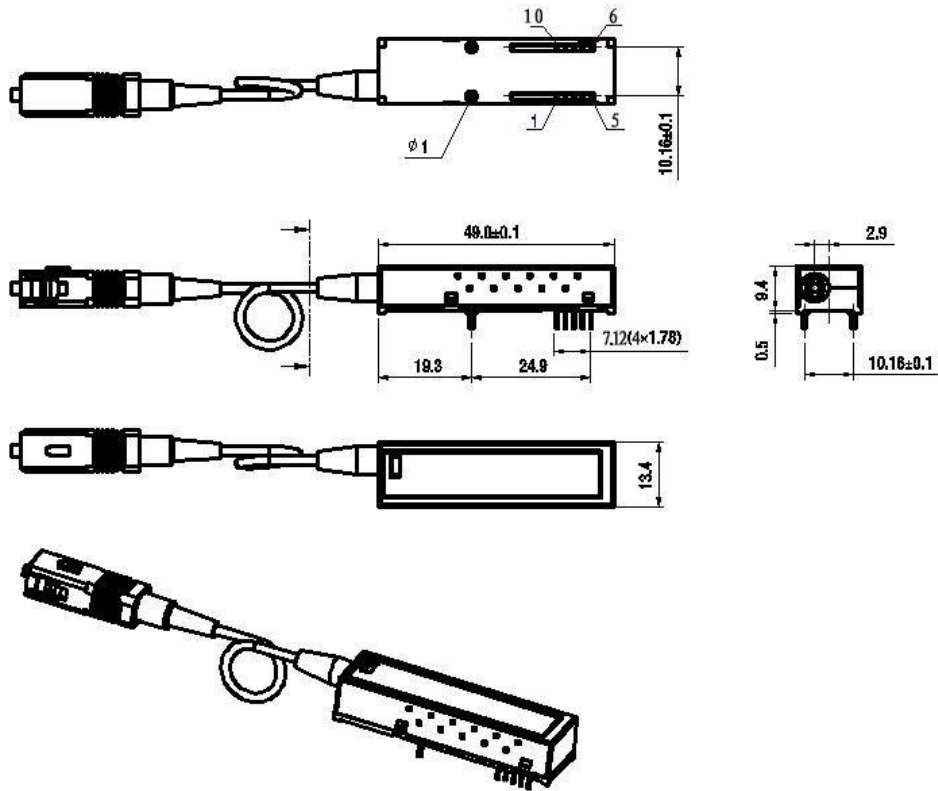

Pigtail

*The pins on the three graphs are only for demonstrate, the dimension for pins is compliant to SFF MSA.

Class 1 Labels

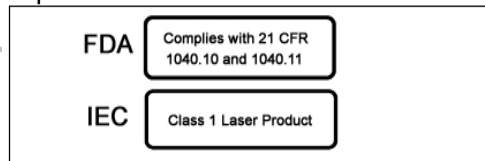

Laser Emission Data

Wavelength	1310nm
Total output power (as defined by FDA: 7mm aperture at 20cm distance)	<0.195mW
Total output power (as defined by IEC: 7mm aperture at 10cm distance)	<15.6mW
Beam divergence	12.5°
Wavelength	1550nm
Total output power (as defined by FDA: 7mm aperture at 20cm distance)	<0.79mW
Total output power (as defined by IEC: 7mm aperture at 10cm distance)	<10mW

Beam divergence	12.5°
-----------------	-------

Laser Emission

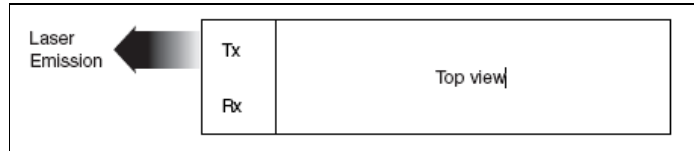

Obtaining Document

You can visit our website: <http://www.eoptolink.com>

Or contact Eoptolink Technology Inc., Ltd. listed at the end of the documentation to get the latest document.

Revision History

Revision	Initiated	Reviewed	Approved	DCN	Release Date
V3.a	Cathy	Kelly.Cao		Released.	Mar 26, 2008

Notice:

Eoptolink reserves the right to make changes to or discontinue any optical link product or service identified in this publication, without notice, in order to improve design and/or performance. Applications that are described herein for any of the optical link products are for illustrative purposes only. Eoptolink makes no representation or warranty that such applications will be suitable for the specified use without further testing or modification.

Contact:

Add: Floor 5, Building 2, No. 21 Gaopeng Avenue, High-Tech District, CHENGDU, SICHUAN

610041 P.R. CHINA

Tel: (+86) 028-85122709 ext 816 & 809

Fax: (+86) 028-85121912

Postal: 610041

E-mail: sales@eoptolink.com

<http://www.eoptolink.com>

Eoptolink