

## EOLX-BI1696-40-AD & EOLX-BI1696-40-DA

Tx: 1270nm/Rx: 1330nm BIDI XFP Transceiver for 10GbE/10FC

Tx: 1330nm/Rx: 1270nm BIDI XFP Transceiver for 10GbE/10FC

RoHS 6 Compliant

### Features

- ◆ Supports 9.95Gb/s to 10.5Gb/s data rates
- ◆ Distance up to 40km over SMF
- ◆ Two types:
  - A: 1270nm DFB Transmitter/ 1330nm Receiver
  - B: 1330nm DFB Transmitter/ 1270nm Receiver
- ◆ LC Connector
- ◆ +3.3V power supply only
- ◆ Power dissipation <2W
- ◆ Built-in digital diagnostic functions
- ◆ Case temperature range:
  - Standard: 0~+70°C
  - Extended: -10~+85°C
- ◆ Complaint with XFP MSA
- ◆ Complaint with IEEE 802.3ae 10GBASE-ER/EW
- ◆ Complaint with 10GFC 1200-SM-LL-L



### Applications

- ◆ 10GBASE-ER 10G Ethernet at 10.3125Gbps
- ◆ 10GBASE-EW 10G Ethernet at 9.953Gbps
- ◆ 1200-SM-LL-L 10G Fiber Channel at 10.51875Gbps

### Ordering information

Part No.	Data Rate	Laser	Temp.	Distance	Optical Interface	DDMI
EOLX-BI1696-40-AD*	10.5Gbps	1270nm DFB	Standard	40km	LC	YES
EOLX-BI1696-40-DA	10.5Gbps	1330nm DFB	Standard	40km	LC	YES
EOLX-BI1696-40-ADI	10.5Gbps	1270nm DFB	Extended	40km	LC	YES
EOLX-BI1696-40-DAI	10.5Gbps	1330nm DFB	Extended	40km	LC	YES

\*Note1: Standard version.

## Regulatory Compliance

Feature	Standard	Performance
Electrostatic Discharge (ESD) to the Electrical Pins	MIL-STD-883G Method 3015.7	Class 1C (>1000 V)
Electrostatic Discharge to the enclosure	EN 55024:1998+A1+A2 IEC-61000-4-2 GR-1089-CORE	Compatible with standards
Electromagnetic Interference (EMI)	FCC Part 15 Class B EN55022:2006 CISPR 22B :2006 VCCI Class B	Compatible with standards Noise frequency range: 30 MHz to 6 GHz. Good system EMI design practice required to achieve Class B margins. System margins are dependent on customer host board and chassis design.
Immunity	EN 55024:1998+A1+A2 IEC 61000-4-3	Compatible with standards. 1kHz sine-wave, 80% AM, from 80 MHz to 1 GHz. No effect on transmitter/receiver performance is detectable between these limits.
Laser Eye Safety	FDA 21CFR 1040.10 and 1040.11 EN (IEC) 60825-1:2007 EN (IEC) 60825-2:2004+A1	CDRH compliant and Class I laser product. TüV Certificate No. 50135086
Component Recognition	UL and CUL EN60950-1:2006	UL file E317337 TüV Certificate No. 50135086 (CB scheme )
RoHS6	2002/95/EC 4.1&4.2 2005/747/EC 5&7&13	Compliant with standards <sup>*note2</sup>

Note2: For update of the equipments and strict control of raw materials, EOPTOLINK has the ability to supply the customized products since Jan 1th, 2007, which meet the requirements of RoHS6 (Restrictions on use of certain Hazardous Substances) of European Union.

In light of item 5 in RoHS exemption list of RoHS Directive 2002/95/EC, Item 5: Lead in glass of cathode ray tubes, electronic components and fluorescent tubes.

In light of item 13 in RoHS exemption list of RoHS Directive 2005/747/EC, Item13: Lead and cadmium in optical and filter glass. The three exemptions are being concerned for Eoptolink's transceivers, because Eoptolink's transceivers use glass, which may contain Pb, for components such as lenses, windows, isolators, and other electronic components.

## Product Description

The EOLX-BI1696-40-XXX series single mode transceiver is small form factor pluggable module

**Eoptolink Technology Inc., Ltd.**

for duplex optical data communications such as 10GBASE-ER/EW defined by IEEE 802.3ae and 10G Fiber Channel 1200-SM-LL-L. It is with the XFP 30-pin connector to allow hot plug capability.

The EOLX-BI1696-40-ADX module is designed for single mode fiber and operates at a nominal wavelength of 1270nm; EOLX-BI1696-40-DAX module is designed for single mode fiber and operates at a nominal wavelength of 1330nm. The transmitter section uses a multiple quantum well DFB, which is class 1 laser compliant according to International Safety Standard IEC-60825.

The receiver section uses an integrated InGaAs detector preamplifier (IDP) mounted in an optical header and a limiting post-amplifier IC.

## Absolute Maximum Ratings\*

Parameter	Symbol	Min	Max	Unit
Maximum Supply Voltage	V <sub>CC</sub>	-0.5	4.0	V
Storage Temperature	T <sub>S</sub>	-40	85	°C
Case Operating Temperature	T <sub>CASE</sub> , EOLX-BI1696-40-AD	0	70	°C
	T <sub>CASE</sub> , EOLX-BI1696-40-ADI	-10	85	

\*Note3: Exceeding any one of these values may destroy the device permanently.

## Recommend operating condition

Parameter	Symbol	Min	Typ	Max	Units
Case Operating Temperature	T <sub>O</sub> , EOLX-BI1696-40-AD	0	-	70	°C
	T <sub>O</sub> , EOLX-BI1696-40-ADI	-10	-	85	
Power Supply Current	I <sub>CC</sub>	-	-	800	mA
Supply Voltage	V <sub>CC</sub>	3.13	-	3.45	V

## Electrical Characteristics

(T<sub>O</sub> = -10 to 85°C, V<sub>CC</sub> = 3.15V to 3.45V)

Parameter	Symbol	Min	Typ	Max	Unit
<b>Transmitter</b>					
Data Rate		9.95	-	10.52	Gbps
Input differential impedance	R <sub>in</sub>	90	100	110	Ω
Differential data input swing* <sup>Note4</sup>	V <sub>in,pp</sub>	120	-	820	mV
Transmit Disable Voltage	V <sub>D</sub>	2.0	-	V <sub>CC</sub>	V
Transmit Enable Voltage	V <sub>EN</sub>	GND	-	GND+ 0.8	V
Transmit Disable Assert Time		-	-	10	us
<b>Receiver</b>					
Differential data output swing* <sup>Note4</sup>	V <sub>out,pp</sub>	340	650	850	mV
Data output rise time* <sup>Note5</sup>	t <sub>r</sub>	-	-	38	ps
Data output fall time* <sup>Note5</sup>	t <sub>f</sub>	-	-	38	ps

LOS Fault	$V_{LOS\ fault}$	2.4	-	V <sub>CC</sub>	V
LOS Normal	$V_{LOS\ norm}$	GND	-	GND+0.5	V

\*Note4. Internal AC coupling.

\*Note5. 20 – 80 %.

## Optical Characteristics

### (EOLX-BI1696-40-ADX, 1270nm DFB & PIN/TIA)

Parameter	Symbol	Min.	Typical	Max.	Unit
9µm Core Diameter SMF			40		km
Data Rate			9.953/10.3125		Gbps
<b>Transmitter</b>					
Centre Wavelength	$\lambda_C$	1260	1270	1280	nm
Spectral Width (-20dB)	$\Delta\lambda$			1	nm
Average Output Power <sup>*note6</sup>	$P_{out, AVG}$	2		7	dBm
Extinction Ratio	ER	3.5			dB
Side Mode Suppression Ratio	SMSR	30			dB
Average Power of OFF Transmitter				-30	dBm
Relative Intensity Noise	RIN			-128	dB/Hz
Input Differential Impedance	$Z_{IN}$	90	100	110	$\Omega$
TX Disable	Disable	2.0		V <sub>CC</sub> +0.3	V
	Enable	0		0.8	
TX Fault	Fault	2.0		V <sub>CC</sub> +0.3	V
	Normal	0		0.8	
TX Disable Assert Time	$t_{off}$			10	us
<b>Receiver</b>					
Centre Wavelength	$\lambda_C$	1320		1340	nm
Sensitivity <sup>*note7</sup>	PIN			-14	dBm
Receiver Overload	$P_{MAX}$	0.5			dBm
Output Differential Impedance	$P_{IN}$	90	100	110	$\Omega$
LOS De-Assert	LOS <sub>D</sub>			-18	dBm
LOS Assert	LOS <sub>A</sub>	-30			dBm
LOS	High	2.0		V <sub>CC</sub> +0.3	V
	Low	0		0.8	

### (EOLX-BI1696-40-DAX, 1330nm DFB & PIN/TIA)

Parameter	Symbol	Min.	Typical	Max.	Unit
9µm Core Diameter SMF			40		km
Data Rate			9.953/10.3125		Gbps
<b>Transmitter</b>					
Centre Wavelength	$\lambda_C$	1320	1330	1340	nm
Spectral Width (-20dB)	$\Delta\lambda$			1	nm
Average Output Power <sup>*note6</sup>	$P_{out, AVG}$	2		7	dBm
Extinction Ratio	ER	3.5			dB

Side Mode Suppression Ratio		SMSR	30			dB
Average Power of OFF Transmitter					-30	dBm
Relative Intensity Noise		RIN			-128	dB/Hz
Input Differential Impedance		Z <sub>IN</sub>	90	100	110	Ω
TX Disable	Disable		2.0		V <sub>CC</sub> +0.3	V
	Enable		0		0.8	
TX Fault	Fault		2.0		V <sub>CC</sub> +0.3	V
	Normal		0		0.8	
TX Disable Assert Time		t <sub>off</sub>			10	us
<b>Receiver</b>						
Centre Wavelength		λ <sub>C</sub>	1260		1280	nm
Sensitivity <sup>*note7</sup>		PIN			-14	dBm
Receiver Overload		P <sub>MAX</sub>	0.5			dBm
Output Differential Impedance		P <sub>IN</sub>	90	100	110	Ω
LOS De-Assert		LOS <sub>D</sub>			-18	dBm
LOS Assert		LOS <sub>A</sub>	-30			dBm
LOS	High		2.0		V <sub>CC</sub> +0.3	V
	Low		0		0.8	

\*Note6. Output is coupled into a 9/125um SMF.

\*Note7: Measured with a PRBS 2<sup>31</sup>-1 test pattern @10.3125Gbps.

## Pin Descriptions

Pin	Logic	Symbol	Name/Description	Ref.
1		GND	Module Ground	1
2		VEE5	Optional -5.2 Power Supply – Not required	
3	LVTTL-I	Mod-Desel	Module De-select; When held low allows the module to , respond to 2-wire serial interface commands	
4	LVTTL-O	<u>Interrupt</u>	Interrupt (bar); Indicates presence of an important condition which can be read over the serial 2-wire interface	2
5	LVTTL-I	TX_DIS	Transmitter Disable; Transmitter laser source turned off	
6		VCC5	+5 Power Supply, Not required	
7		GND	Module Ground	1
8		VCC3	+3.3V Power Supply	
9		VCC3	+3.3V Power Supply	
10	LVTTL-I	SCL	Serial 2-wire interface clock	2
11	LVTTL-I/O	SDA	Serial 2-wire interface data line	2
12	LVTTL-O	Mod_Abs	Module Absent; Indicates module is not present. Grounded in the module.	2
13	LVTTL-O	Mod_NR	Module Not Ready;	2

14	LVTTTL-O	RX_LOS	Receiver Loss of Signal indicator	2
15		GND	Module Ground	1
16		GND	Module Ground	1
17	CML-O	RD-	Receiver inverted data output	
18	CML-O	RD+	Receiver non-inverted data output	
19		GND	Module Ground	1
20		VCC2	+1.8V Power Supply – Not required	
21	LVTTTL-I	P_Down/R ST	Power Down; When high, places the module in the low power stand-by mode and on the falling edge of P_Down initiates a module reset	
			Reset; The falling edge initiates a complete reset of the module including the 2-wire serial interface, equivalent to a power cycle.	
22		VCC2	+1.8V Power Supply – Not required	
23		GND	Module Ground	1
24	PECL-I	RefCLK+	Reference Clock non-inverted input, AC coupled on the host board – Not required	3
25	PECL-I	RefCLK-	Reference Clock inverted input, AC coupled on the host board – Not required	3
26		GND	Module Ground	1
27		GND	Module Ground	1
28	CML-I	TD-	Transmitter inverted data input	
29	CML-I	TD+	Transmitter non-inverted data input	
30		GND	Module Ground	1

### Notes:

1. Module circuit ground is isolated from module chassis ground within the module.
2. Open collector; should be pulled up with 4.7k – 10k ohms on host board to a voltage between 3.15V and 3.6V.
3. A Reference Clock input is not required.

## Pin Arrangement

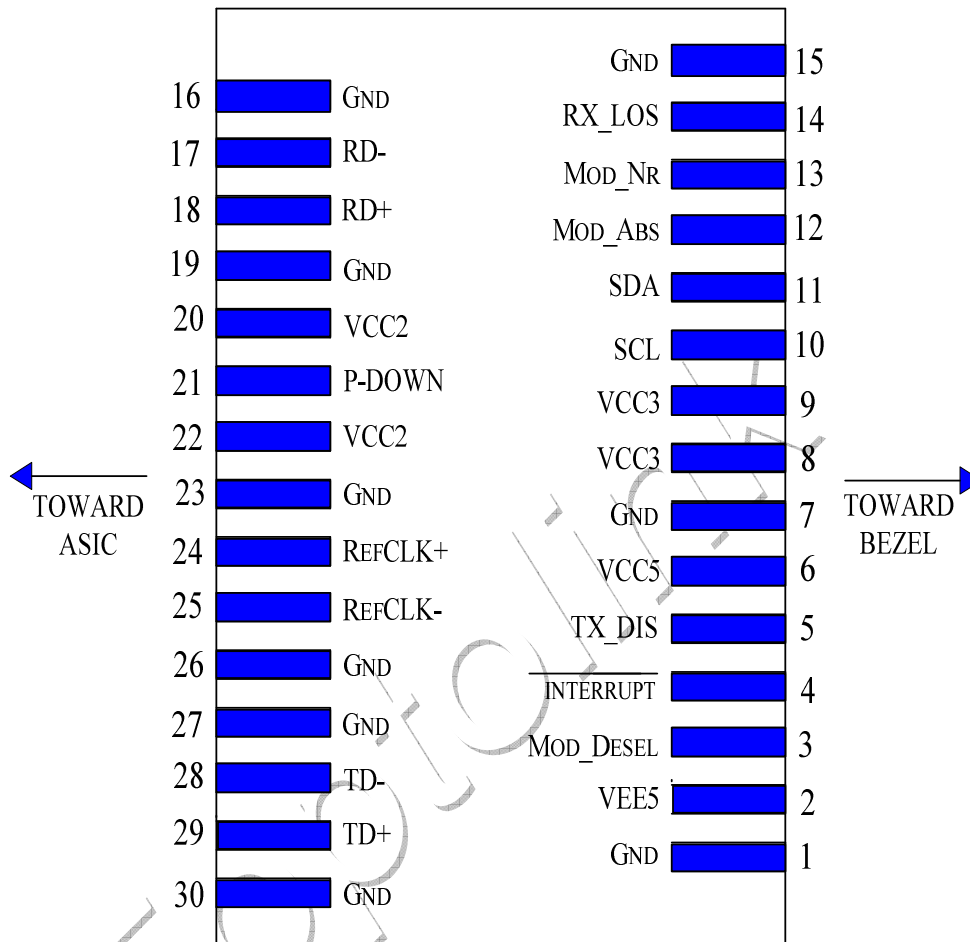

**Diagram of Host Board Connector Block Pin Numbers and Name**

## Digital Diagnostic Functions

Eoptolink's EOLX-BI1696-40-XX Small Form Factor 10Gb/s (XFP) transceivers are compliant with the current XFP Multi-Source Agreement (MSA) Specification Rev 4.5.

As defined by the XFP MSA, Eoptolink XFP transceivers provide digital diagnostic functions via a 2-wire serial interface, which allows real-time access to the following operating parameters:

- ◆ Transceiver temperature
- ◆ Laser bias current
- ◆ Transmitted optical power
- ◆ Received optical power
- ◆ Transceiver supply voltage

The structure of the memory map is shown in the following figure, which is accessible over a 2-wire serial interface at the 8-bit address 1010000X (A0h). The normal 256 byte I<sup>2</sup>C address space is divided into low and upper blocks of 128 Bytes. The lower block of 128 Bytes is always

directly available and is used for the diagnostics and control function. Multiple blocks of memories are available in the upper 128 Bytes of the address space. These are individually addressed through a table select Byte which the user enters into a location in the lower address space. Thus, there is a total available address space of  $128 \times 256 = 32$  Kbytes in this upper memory space. The contents of Table 01h are listed in following table. Please refer SFF INF-8077i (Revision 4.5) for detailed information.

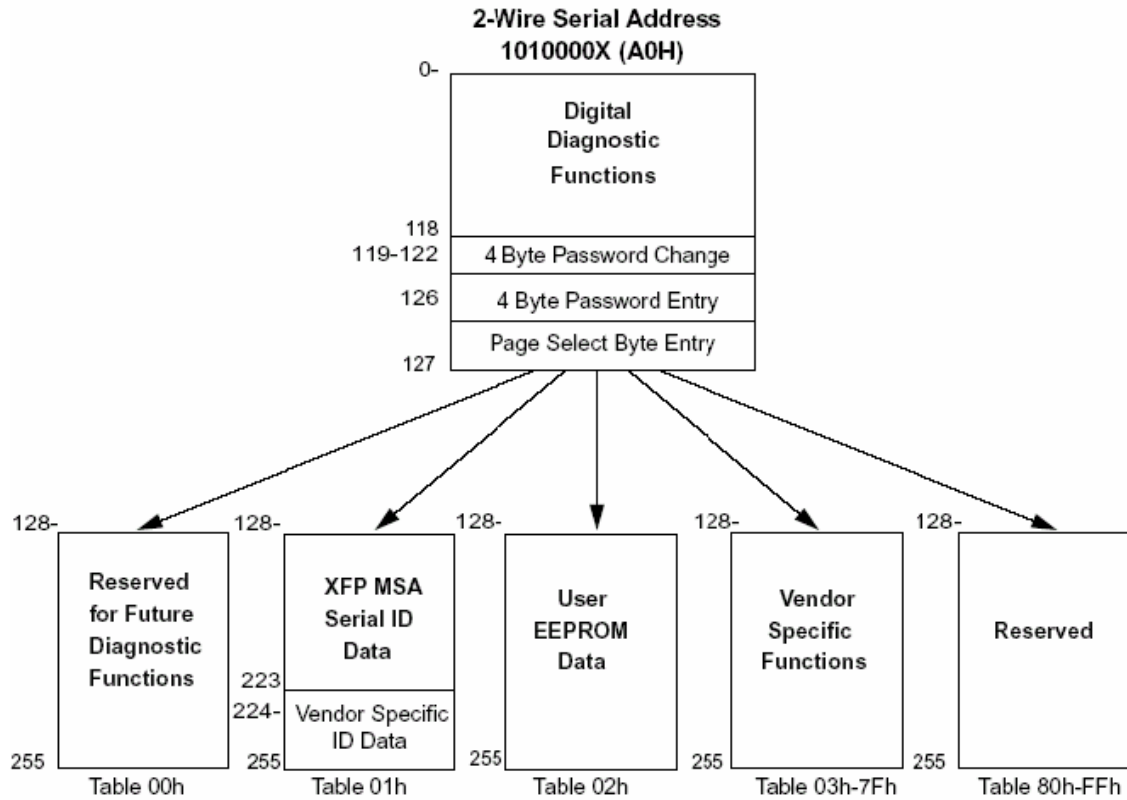

### Monitor Specification:

Data Address	Parameter	Accuracy
96 ~ 97	Temperature	± 3°C
98 ~ 99	Reserved	
100~101	Tx Bias	±10%
102~103	Tx Power	±2dB
104~105	Rx Power	± 2dB
106~107	Vcc3	± 3%

## Recommended Host Board Power Supply Circuit

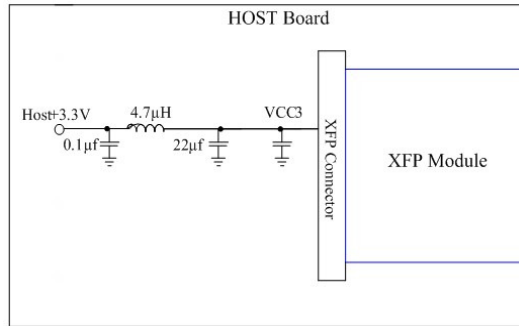

## Recommended High-speed Interface Circuit

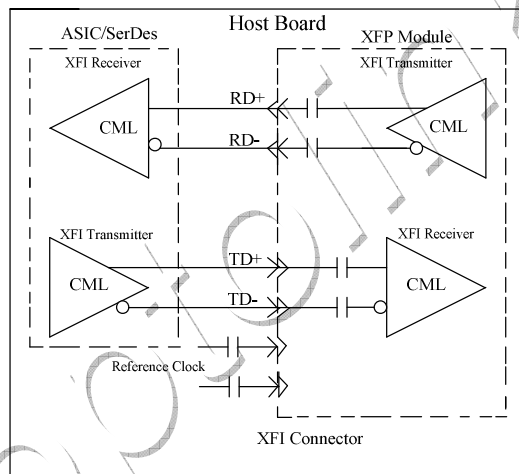

## Mechanical Specifications

Eoptolink's XFP transceivers are compliant with the dimensions defined by the XFP Multi-Sourcing Agreement (MSA).

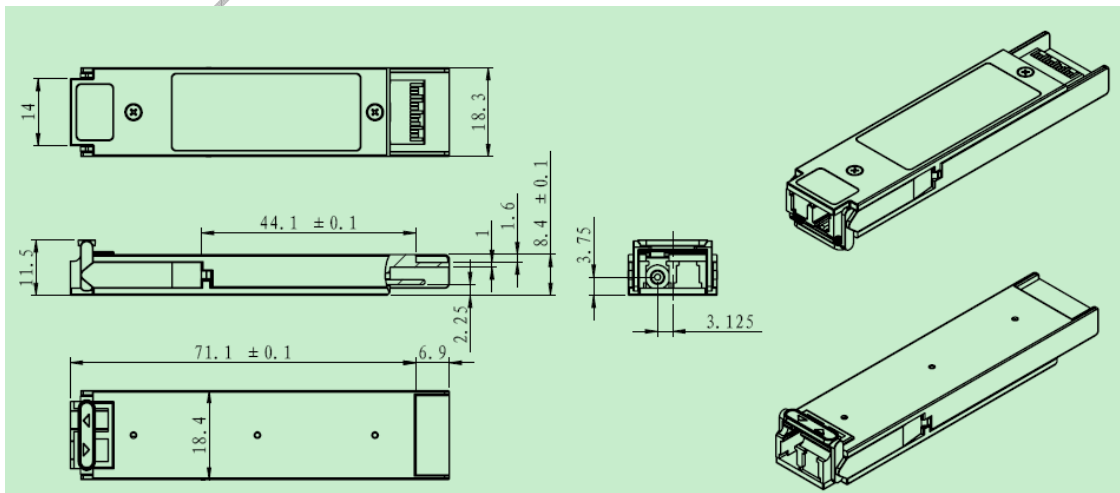

## Eye Safety

This single-mode transceiver is a Class 1 laser product. It complies with IEC-60825 and FDA 21 CFR 1040.10 and 1040.11. The transceiver must be operated within the specified temperature and voltage limits. The optical ports of the module shall be terminated with an optical connector or with a dust plug.

## Obtaining Document

You can visit our website:

<http://www.eoptolink.com>

Or contact Eoptolink Technology Inc., Ltd. listed at the end of the documentation to get the latest documents.

## Revision History

Revision	Initiated	Reviewed	Approved	DCN	Release Date
V1.a	Kelly	Phlio, Alex		Released.	Dec 8, 2009

## Notice:

Eoptolink reserves the right to make changes to or discontinue any optical link product or service identified in this publication, without notice, in order to improve design and/or performance. Applications that are described herein for any of the optical link products are for illustrative purposes only. Eoptolink makes no representation or warranty that such applications will be suitable for the specified use without further testing or modification.

## Contact:

Add: Floor 5 Building 2 No. 21 Gaopeng Avenue High-Tech District CHENGDU, SICHUAN  
610041 P.R. CHINA

Tel: (+86) 028-85122709 ext 816 & 809

Fax: (+86) 028-85121912

Postal: 610041

E-mail: [sales@eoptolink.com](mailto:sales@eoptolink.com)

<http://www.eoptolink.com>