

EOL9-BI1x03-2M Series

**Single-Mode 155Mbps
Single Fiber Bi-Directional
SC/FC/ST Transceiver
RoHS6 Compliant**

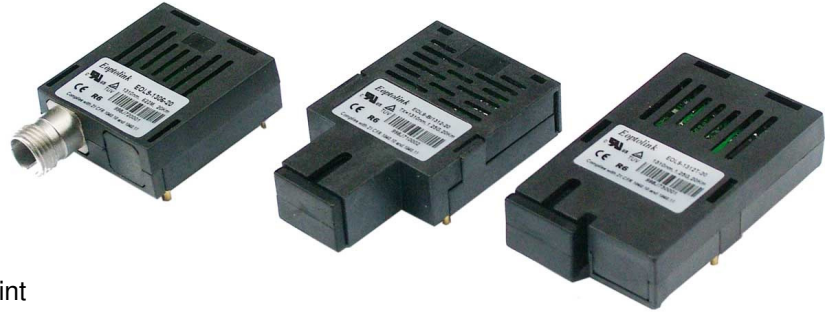

Features

- ◆ Support 155Mbps data link
- ◆ Industry Standard 1 x 9 Footprint
- ◆ A type: 1310nmFP Tx/1550nmRx
B type: 1550nmFP Tx/1310nmRx
- ◆ 2Km with 50/125um MMF at Least
- ◆ 3.3V or 5V single power supply
- ◆ PECL signal input and output ^{*note1}
- ◆ Signal detect indicator (PECL version) ^{*note1}
- ◆ Wave Solderable and Aqueous Washable with process plug inserted
- ◆ Class 1 FDA and IEC60825-1 laser safety compliant
- ◆ Operating Case Temperature
Standard: 0°C~+70°C
Industrial:-40°C~+85°C

Applications

- ◆ ATM 155 Mbps Link
- ◆ SONET/SDH Equipment Interconnect
- ◆ Fast Ethernet
- ◆ Switch to Switch Interface
- ◆ Digital video transmission system

Ordering information

Part No.	Input/Output	SD	Distance	Wavelength	Voltage	Interface	Temp.
EOL9-BI1303-2M ^{*note2}	DC	PECL	2Km	1310nm	3.3V/5V	SC	Standard
EOL9-BI1503-2M ^{*note2}	DC	PECL	2Km	1550nm	3.3V/5V	SC	Standard

*Other ordering information in detail refers to the denominate rule on next page.

Note1: 5V for PECL or TTL, 3.3V for LVPECL or LVTTTL

Note2: Standard version

Nomenclature

Symmetrical 1X9 BIDI

EOL9- -

A B C D E F G H I J K

No.	Parameter	Detailed Description					
A	Module Type	9=1X9					
B	Laser style	BI					
C	Wavelength	13=1310nm			15=1550nm		
D	Data Rate	03=155M					
E	Blank						
F	Distance	02=850nm, MMF			XM=X Km (1310nm, MMF, X=1~9)		
		X=X *10Km (SM,X=1~9)			A=100Km		
G	Blank						
H	Blank						
I	Temperature	I=-40~+85□			Blank=0~+70□		
J	Connector	Blank=SC	T=ST	F=FC	P=Pigtail/ SC/PC	PF=Pigtail/ FC/PC	PT=Pigtail/ ST/PC
K	Voltage	Blank=3.3/5V		V=3.3V		H=5V	
Option	Input/output & SD	Blank=Input: DC; Output: DC; SD-TTL (FC/GBE/2FC/OC48)			Blank=Input: DC; Output: DC; SD-PECL(OC-3/STM-4)		
		1=Input: AC; Output: AC; SD-TTL (FC/GBE/2FC/OC48)			1=Input: AC; Output: AC; SD-PECL (OC-3/STM-4)		
		2= Input: DC; Output: DC; SD-PECL (FC/GBE/2FC/OC48)			2=Input: DC; Output: DC; SD-TTL (OC-3/STM-4)		
		3= Input: AC; Output: AC; SD-PECL (FC/GBE/2FC/OC48)			3= Input: AC; Output: AC; SD-TTL (OC-3/STM-4)		
	Case type	Blank=case 1(standard, middle output)			S=case 2(side output)		

Regulatory Compliance

Feature	Standard	Performance
Electrostatic Discharge (ESD) to the Electrical Pins	MIL-STD-883G Method 3015.7	Class 1C (>1000 V)
Electrostatic Discharge to the enclosure	EN 55024:1998+A1+A2 IEC-61000-4-2 GR-1089-CORE	Compliant with standards
Electromagnetic Interference (EMI)	FCC Part 15 Class B EN55022:2006 CISPR 22B :2006 VCCI Class B	Compliant with standards Noise frequency range: 30 MHz to 6 GHz. Good system EMI design practice required to achieve Class B margins. System margins are dependent on customer host board and chassis design.
Immunity	EN 55024:1998+A1+A2 IEC 61000-4-3	Compliant with standards. 1kHz sine-wave, 80% AM, from 80 MHz to 1 GHz. No effect on transmitter/receiver performance is detectable between these limits.
Laser Eye Safety	FDA 21CFR 1040.10 and 1040.11 EN (IEC) 60825-1:2007 EN (IEC) 60825-2:2004+A1	CDRH compliant and Class I laser product. TüV Certificate No. 50135086
Component Recognition	UL and CUL EN60950-1:2006	UL file E317337 TüV Certificate No. 50135086 (CB scheme)
RoHS6	2002/95/EC 4.1&4.2 2005/747/EC 5&7&13	Compliant with standards ^{*note3}

Note 3: For update of the equipments and strict control of raw materials, EOPTOLINK has the ability to supply the customized products since Jan 1st, 2007, which meet the requirements of RoHS6 (Restrictions on use of certain Hazardous Substances) of European Union.

In light of item 5 in RoHS exemption list of RoHS Directive 2002/95/EC, Item 5: Lead in glass of cathode ray tubes, electronic components and fluorescent tubes.

In light of item 13 in RoHS exemption list of RoHS Directive 2005/747/EC, Item 13: Lead and cadmium in optical and filter glass. The three exemptions are being concerned for Eoptolink's transceivers, because Eoptolink's transceivers use glass, which may contain Pb, for optical components such as lenses, isolators, and other electronic components.

Interface information

The Signal Detect (SD, active high), Normal optical input of receiver represents to a logic "1" level,

which means asserted.

The following versions are available:

1. AC/AC Transceiver

Tx and Rx are AC coupling. Tx has differential 100Ω load.

2. DC/DC Transceiver

Standard PECL inputs and outputs, Tx and Rx are DC coupling.

Product Description

The EOL9-BI1x03-2M series is high performance module for OC-3/STM-1 and Fast Ethernet single fiber communication by using 1310nm/1550nm transmitter and 1550nm/1310nm receiver.

The transmitter section uses a multiple quantum well laser and is a class 1 laser compliant according to International Safety Standard IEC 60825. The receiver section uses an integrated detector preamplifier (IDP) mounted in an optical header and a limiting post-amplifier IC.

A PECL logic interface simplifies interface to the external circuitry.

Absolute Maximum Ratings

Parameter	Symbol	Min.	Max.	Unit	
Storage Temperature	T_s	-40	+85	°C	
Supply Voltage	V_{CC}	5V	-0.5	7.0	V
		3.3V	-0.5	5.5	
Operating Relative Humidity	-		95	%	
Soldering Conditions Temp/Time			260/10	°C/s	

*Exceeding any one of these values may destroy the device immediately.

Recommended Operating Conditions

Parameter	Symbol	Min.	Typical	Max.	Unit
Operating Case Temperature	T_A	0		+70	°C
		-40		+85	
Power Supply Voltage	V_{CC}	4.75	5	5.25	V
		3.15	3.3	3.45	
Power Supply Current ^{*(note4)}	I_{CC}			300	mA
Data Rate			155		Mbps

Note4: Maximum current is specified at Vcc equaling to Maximum @ maximum temperature.

Optical and Electrical Characteristic

(EOL9-BI1303-2M Series, FP and PIN)

Parameter	Symbol	Min.	Typical	Max.	Unit
Transmitter					
Centre Wavelength	λ_C	1260	1310	1360	nm
Spectral Width	$\Delta\lambda$			5	nm
Average Output Power ^{*(note5)}	P_{out}	-19		-14	dBm
Extinction Ratio	ER	9			dB
Rise/Fall Time (20%---80%)	tr/tf			2	ns
Relative Intensity Noise	RIN			-117	dB/Hz
Total Jitter	TJ			1	ns
Data Input Swing Differential	V_{in}	400		2000	mV
Input Differential Impedance	Z_{in}	90	100	110	Ω
Input High Voltage	V_H	-1165		-880	mV
Input Low Voltage	V_L	-1810		-1475	mV
Eye Diagram	IUT-T G.957 Compliant ^{*(note7)}				
Data Input	PECL ^{*(note1)}				
Receiver					
Receiver Rate		155			Mbps
Input center wavelength	λ	1480	1550	1580	nm
Receiver Sensitivity ^{*(note6)}	P_{min}			-30	dBm
Receiver Overload	P_{max}	-5			dBm
SD Assert	SDA			-31	dBm
SD De-Assert	SDD	-45			dBm
SD Hysteresis ^{*(note8)}		0.5			dB
Output High Voltage	V_H	-1165		-880	mV
Output Low Voltage	V_L	-1810		-1475	mV
SD Voltage(TTL-H) ^{*(note1)}	V_H	2			V
SD Voltage (TTL-L) ^{*(note1)}	V_L			0.8	V
SD Voltage(PECL-H) ^{*(note1)}	V_H	-1.1		-0.74	V
SD Voltage (PECL-L) ^{*(note1)}	V_L	-2.0		-1.58	V
Data Output	PECL ^{*(note1)}				

(EOL9-BI1503-2M Series, FP and PIN)

Parameter	Symbol	Min.	Typical	Max.	Unit
Transmitter					
Centre Wavelength(0~70□)	λ_C	1480	1550	1580	nm
Spectral Width	$\Delta\lambda$			5	nm
Average Output Power ^{*(note5)}	P_{out}	-19		-14	dBm
Extinction Ratio	ER	9			dB
Rise/Fall Time (20%---80%)	tr/tf			2	ns
Relative Intensity Noise	RIN			-117	dB/Hz

Total Jitter	TJ			1	ns
Data Input Swing Differential	V _{in}	400		2000	mV
Input Differential Impedance	Z _{in}	90	100	110	Ω
Input High Voltage	V _H	-1165		-880	mV
Input Low Voltage	V _L	-1810		-1475	mV
Eye Diagram	IUT-T G.957 Compliant ^{*(note7)}				
Data Input	PECL ^{*(note1)}				
Receiver					
Receiver Rate	155				Mbps
Input center wavelength	λ	1260		1360	nm
Receiver Sensitivity ^{*(note6)}	P _{min}			-30	dBm
Receiver Overload	P _{max}	-5			dBm
SD Assert	SDA			-31	dBm
SD De-Assert	SDD	-45			dBm
SD Hysteresis ^{*(note8)}		0.5			dB
Output High Voltage	V _H	-1165		-880	mV
Output Low Voltage	V _L	-1810		-1475	mV
SD Voltage(TTL-H) ^{*(note1)}	V _H	2			V
SD Voltage (TTL-L) ^{*(note1)}	V _L			0.8	V
SD Voltage(PECL-H) ^{*(note1)}	V _H	-1.1		-0.74	V
SD Voltage (PECL-L) ^{*(note1)}	V _L	-2.0		-1.58	V
Data Output	PECL ^{*(note1)}				

Note5: The optical power is launched into 50/125um MMF.

Note6: Minimum average optical power measured at the BER less than 1E-12, with a 2²³-1 NRZ PRBS and ER of source is 9dB.

Note7: Eye pattern mask

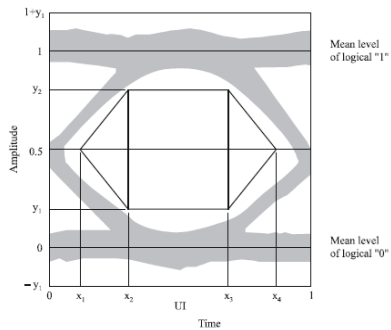

Note8: LOS Hysteresis

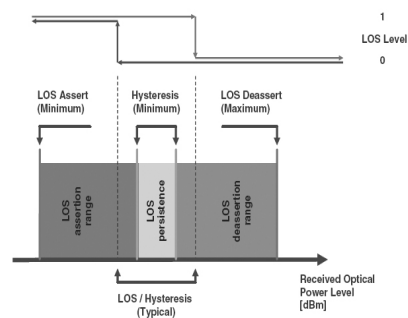

Pin Description

Pin	Name	Level	Description
1	Veer		Receiver Signal Ground, connect to receiver signal ground plane directly
2	RD+	PECL ^{*(note1)}	Receiver data out
3	RD-	PECL ^{*(note1)}	Inverted receiver data out

4	SD	PECL ^{*(note1)}	Signal Detect, TTL (Load resistor > 4.7KΩ)or PECL output, Normal optical input levels to the receiver result in a logic “1” output, asserted. Low input levels to the receiver result in a fault condition indicated by a logic “0”output, de-asserted.
5	Vccr		Receiver Power Supply, provide +5V (+3.3V) the recommended receiver power supply filter circuit. Locate the power filter circuit as close as possible to the Vccr pin
6	Vcct		Transmitter Power Supply, provide +5V DC(+3.3V) via the recommended transmitter power supply filter circuit. Locate the power filter circuit as close as possible to the Vcct pin
7	TD-	PECL ^{*(note1)}	Inverted transmitter Data in
8	TD+	PECL ^{*(note1)}	Transmitter Data in
9	Veet		Transmitter Signal Ground, connect to the transmitter signal ground planed directly

Pin Definitions

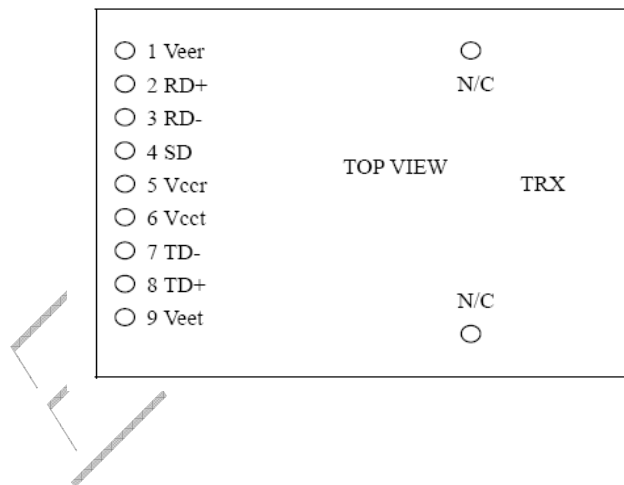

Recommended Circuit

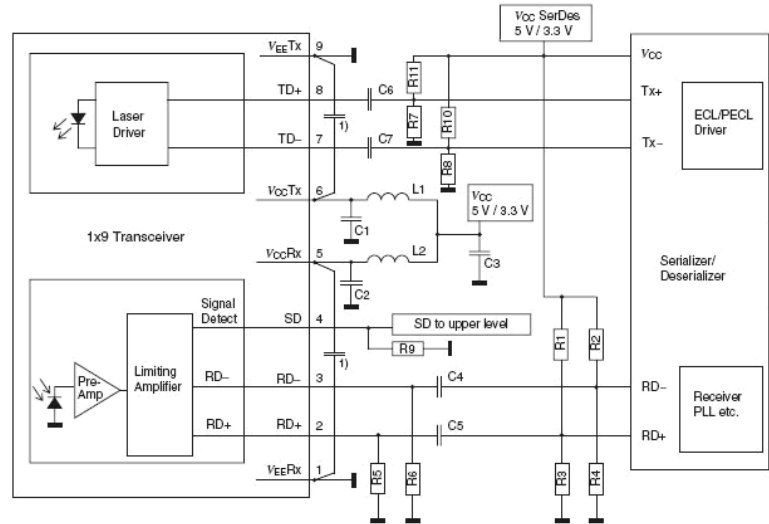

- | | |
|-----------------------------|---|
| C1/2/3 = 4.7 μ F | R10/11 = 82 Ω (5 V) |
| C4/5/6/7 = 100 nF | = 127 Ω (3.3 V) |
| L1/2 = 1 μ H | (depends on SerDes chip used) |
| R5/6 = 270 Ω (5 V) | Place R1/2/3/4 close to SerDes chip, depends on SerDes chip used. |
| = 150 Ω (3.3 V) | Place R5/6/7/8/10/11 close to 1x9 transceiver. |
| R7/8 = 127 Ω (5 V) | |
| = 82 Ω (3.3 V) | |
| R9 = open (5 V/3.3 V TTL) | |
| = 510 Ω (5 V PECL) | |
| = 270 Ω (3.3 V PECL) | |

DC Coupling inside

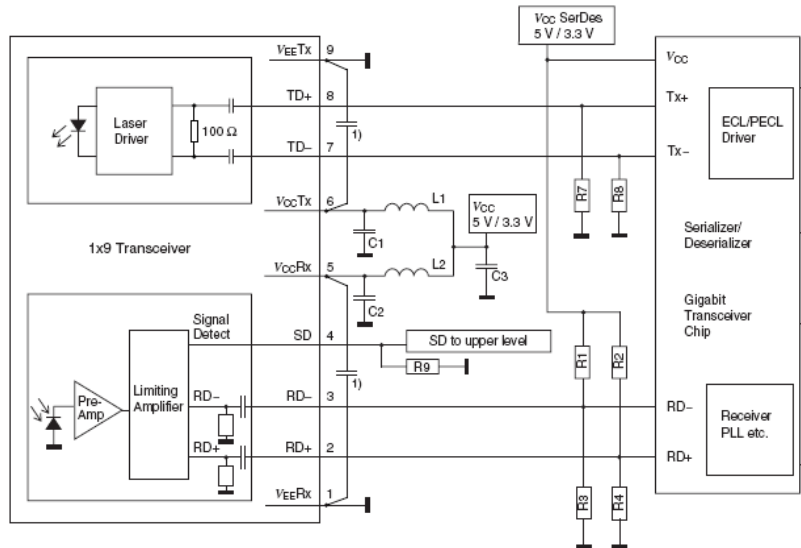

- | | |
|---|--|
| C1/2/3 = 4.7 μ F | Place R1/2/3/4/7/8 close to SerDes chip. |
| L1/2 = 1 μ H | Place R5/6 close to 1x9 transceiver. |
| R1/2/3/4 = Depends on SerDes chip used | |
| R7/8 = Biasing (depends on SerDes chip) | |
| R9 = open (5 V/3.3 V TTL) | |
| = 510 Ω (5 V PECL) | |
| = 270 Ω (3.3 V PECL) | |

AC Coupling inside

Package outline (Unit: mm)

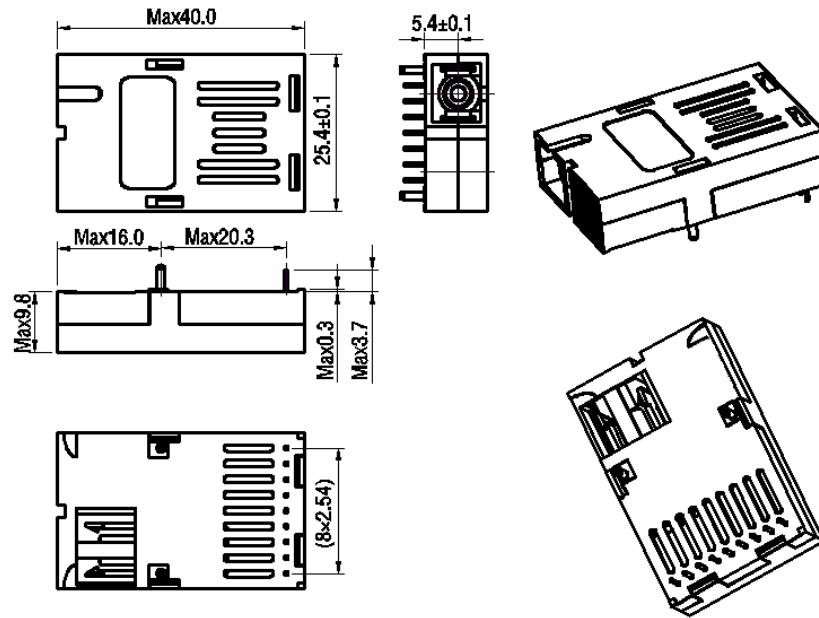

SC receptacle side output

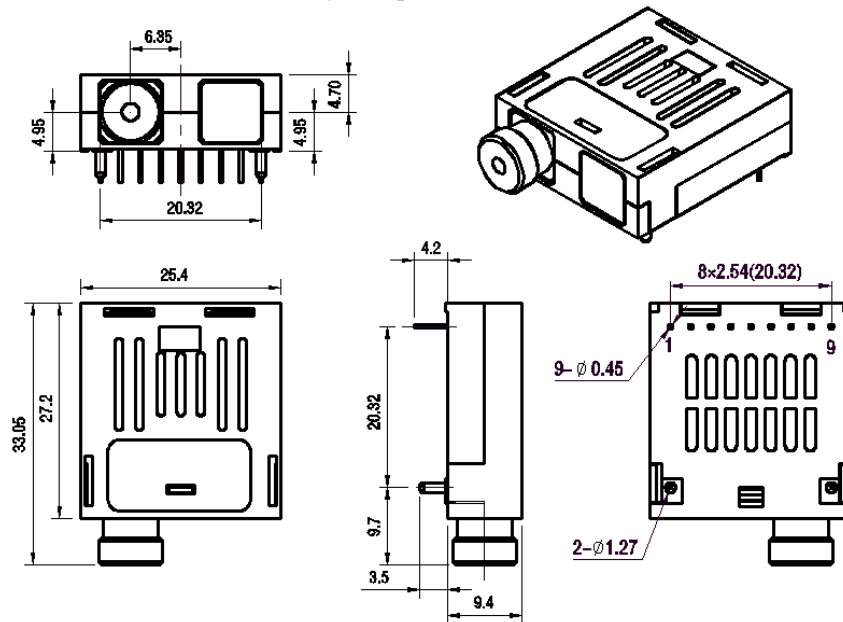

FC receptacle

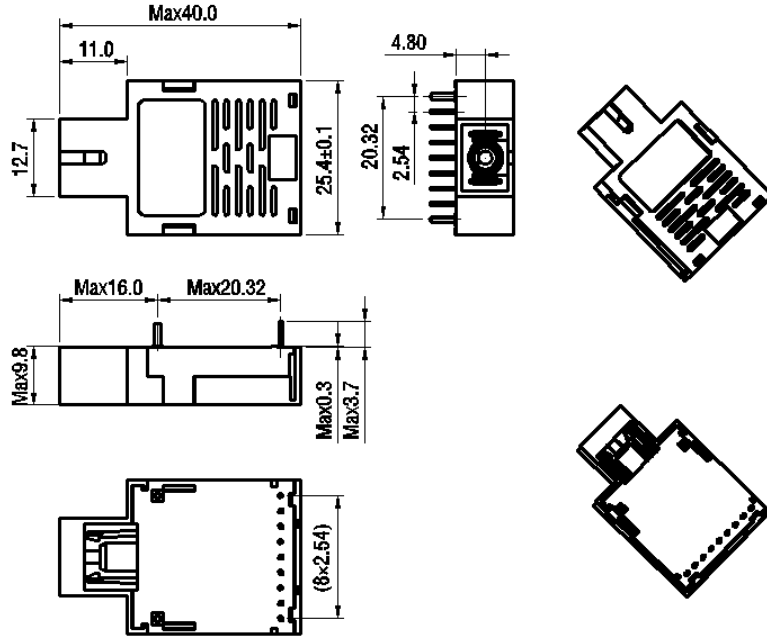

SC receptacle middle output

Class 1 Labels

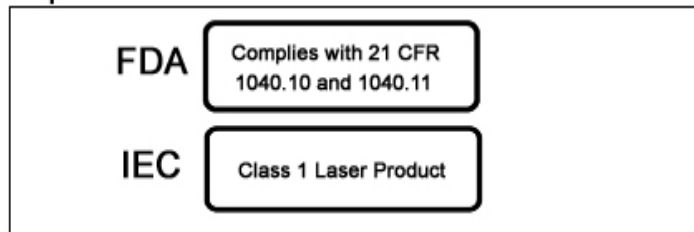

Laser Emission Data

Wavelength	1310nm
Total output power (as defined by FDA: 7 mm aperture at 20 cm distance)	< 0.195mW
Total output power (as defined by IEC: 7 mm aperture at 10 cm distance)	< 15.6mW
Beam divergence	12.5°
Wavelength	1550nm
Total output power (as defined by FDA: 7 mm aperture at 20 cm distance)	<0.79mW
Total output power (as defined by IEC: 7 mm aperture at 10 cm distance)	<10mW
Beam divergence	12.5°

Laser Emission

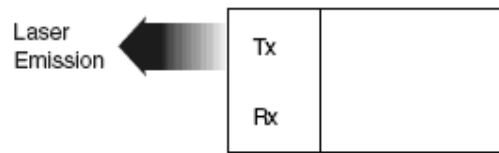

Obtaining Document

You can visit our website:

<http://www.eoptolink.com>

Or contact Eoptolink Technology Inc., Ltd. listed at the end of the documentation to get the latest documentation.

Revision History

Revision	Initiated	Reviewed	Approved	DCN	Release Date
V2.a	Tim.Liang	Kelly.Cao		Released.	Jun 12th, 2007
V2.b	Kelly.Cao	Kelly.Cao		Delete item7 in note3.	Dec 23, 2009
V2.c	Kelly			Change logo.	Jan 12, 2010

Notice:

Eoptolink reserves the right to make changes or discontinue any product or service identified in this publication, without notice, in order to improve design and/or performance. Applications that are described herein for any of the products are for illustrative purposes only. Eoptolink makes no representation or warranty that such applications will be suitable for the specified use without further testing or modification.

Contact:

Add: Floor 5 Building 2 No. 21 Gaopeng Avenue High-Tech District CHENGDU, SICHUAN 610041
P.R. CHINA

Tel: (+86) 028-85122709 ext 816 & 809

Fax: (+86) 028-85121912

Postal: 610041

E-mail: sales@eoptolink.com

<http://www.eoptolink.com>