

EOL9-1603-80X Series

Single-Mode 155Mbps 1270~1610nm
 CWDM Duplex 1 x 9 Transceiver
 RoHS6 Compliant

Features

- ◆ Duplex SC/FC/ST Single-Mode Transceiver
- ◆ Industry Standard 1 x 9 Footprint
- ◆ CWDM DFB-LD Transmitter
- ◆ 3.3V or 5V single power supply
- ◆ PECL signal input and output, supporting 125Hz signaling^{*note1}
- ◆ Signal detect indicator (PECL version)^{*note1}
- ◆ Wave Solderable and Aqueous Washable with process plug inserted
- ◆ Class 1 FDA and IEC60825-1 laser safety compliant
- ◆ 80km with 9/125um SMF at Least
- ◆ Operating Case Temperature
Standard: 0°C~+70°C



Applications

- ◆ ATM 155 Mbps Links
- ◆ SONET/SDH Equipment Interconnect
- ◆ Fast Ethernet
- ◆ Switch to Switch Interface
- ◆ Digital video transmission system

Ordering information

Part No.	Input	Output	SD	Distance	Voltage	Interface	Temp.
EOL9-1603-80 ^{*note2}	DC	DC	PECL	80km	3.3V/5V	SC	Standard
EOL9-1603-801	AC	AC	PECL	80km	3.3V/5V	SC	Standard

*Other ordering information in detail refers to the denominate rule on next page.

Note1: 5V for PECL or TTL, 3.3V for LVPECL or LVTTTL

Note2: Standard version. X refers to CWDM center wavelength, from 1470nm to 1610nm.

Nomenclature

Symmetrical 1X9 Duplex

EOL9- - -
 A B C D E F G H I J K

No.	Parameter	Detailed Description					
A	Module Type	9=1X9					
B	blank						
C	Wavelength	16=WDM					
D	Data Rate	03=155M					
E	Blank						
F	Distance	02=850nm, MMF			XM=X Km (1310nm, MMF, X=1~9)		
		X=X*10Km (SM,X=1~9)			A=100Km		
G	TX Wavelength	A=1270..K=1470nm, L=1490nm ... R=1610nm. Refer to form ordering information.					
H	Blank						
I	Temperature	I=-40~+85C			Blank=0~+70C		
J	Connector	Blank=SC	T=ST	F=FC	P=Pigtail/SC/PC	PF=Pigtail/FC/PC	PT=Pigtail/ST/PC
K	Voltage	Blank=3.3/5V		V=3.3V		H=5V	
Option	Input/output & SD	Blank=Input: DC; Output: DC; SD-TTL (FC/GBE/2FC/OC48)			Blank=Input: DC; Output: DC; SD-PECL(OC-3/STM-4)		
		1=Input: AC; Output: AC; SD-TTL (FC/GBE/2FC/OC48)			1=Input: AC; Output: AC; SD-PECL (OC-3/STM-4)		
		2=Input: DC; Output: DC; SD-PECL (FC/GBE/2FC/OC48)			2=Input: DC; Output: DC; SD-TTL (OC-3/STM-4)		
		3=Input: AC; Output: AC; SD-PECL (FC/GBE/2FC/OC48)			3=Input: AC; Output: AC; SD-TTL (OC-3/STM-4)		

CWDM* Wavelength from 1470nm to 1610nm (0~70□)

Band	Nomenclature	Wavelength(nm)		
		Min.	Typ.	Max.
O-band Original	A	1264	1270	1277.5
	B	1284	1290	1297.5
	C	1304	1310	1317.5
	D	1324	1330	1337.5
	E*	1344	1350	1357.5
E-band Extended	F*	1364	1370	1377.5
	G*	1384	1390	1397.5

	H*	1404	1410	1417.5
	I*	1424	1430	1437.5
	J*	1444	1450	1457.5
S-band Short Wavelength	K	1464	1470	1477.5
	L	1484	1490	1497.5
	M	1504	1510	1517.5
	N	1524	1530	1537.5
C-band Conventional	O	1544	1550	1557.5
L-band Long Wavelength	P	1564	1570	1577.5
	Q	1584	1590	1597.5
	R	1604	1610	1617.5

CWDM*: 8 Wavelengths from 1470nm to 1610nm, each step 20nm.

Regulatory Compliance

Feature	Standard	Performance
Electrostatic Discharge (ESD) to the Electrical Pins	MIL-STD-883G Method 3015.7	Class 1C (>1000 V)
Electrostatic Discharge to the enclosure	EN 55024:1998+A1+A2 IEC-61000-4-2 GR-1089-CORE	Compliant with standards
Electromagnetic Interference (EMI)	FCC Part 15 Class B EN55022:2006 CISPR 22B :2006 VCCI Class B	Compliant with standards Noise frequency range: 30 MHz to 6 GHz. Good system EMI design practice required to achieve Class B margins. System margins are dependent on customer host board and chassis design.
Immunity	EN 55024:1998+A1+A2 IEC 61000-4-3	Compliant with standards. 1kHz sine-wave, 80% AM, from 80 MHz to 1 GHz. No effect on transmitter/receiver performance is detectable between these limits.
Laser Eye Safety	FDA 21CFR 1040.10 and 1040.11 EN (IEC) 60825-1:2007 EN (IEC) 60825-2:2004+A1	CDRH compliant and Class I laser product. TüV Certificate No. 50135086
Component Recognition	UL and CUL EN60950-1:2006	UL file E317337 TüV Certificate No. 50135086 (CB scheme)

RoHS6	2002/95/EC 4.1&4.2 2005/747/EC 5&7&13	Compliant with standards ^{*note3}
-------	--	--

Note3: For update of the equipments and strict control of raw materials, EOPTOLINK has the ability to supply the customized products since Jan 1st, 2007, which meet the requirements of RoHS6 (Restrictions on use of certain Hazardous Substances) of European Union.

In light of item 5 in RoHS exemption list of RoHS Directive 2002/95/EC, Item 5: Lead in glass of cathode ray tubes, electronic components and fluorescent tubes.

In light of item 7 in RoHS exemption list of RoHS Directive 2005/747/EC, Item 7: Lead in high melting temperature type solders (i.e. lead-based alloys containing 85% by weight or more lead). Lead in solder for servers, storage and storage array systems, network infrastructure equipment for switching, signaling, transmission as well as network management for telecommunications. Lead in electronic ceramic parts (e.g. piezoelectronic devices).

In light of item 13 in RoHS exemption list of RoHS Directive 2005/747/EC, Item 13: Lead and cadmium in optical and filter glass. The three exemptions are being concerned for Eoptolink's transceivers, because Eoptolink's transceivers use glass, which may contain Pb, for optical components such as lenses, isolators, and other electronic components.

Functional Diagram

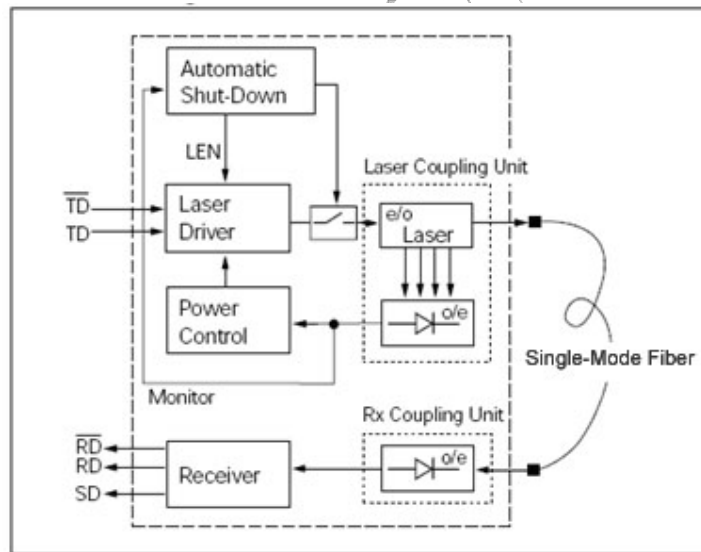

The Signal Detect (SD, active high), Normal optical input of receiver represents to a logic "1" level, which means asserted.

The following versions are available:

1. AC/AC Transceiver

Tx and Rx are AC coupling. Tx has differential 100Ω load.

2. DC/DC Transceiver

Standard PECL inputs and outputs, Tx and Rx are DC coupling.

Product Description

The EOL9-1603-80X Series Single-mode transceivers are low power, high performance modules for duplex optical data communications such as SONET OC-3/SDH STM-1 and Fast Ethernet.

The transmitter section uses a multiple quantum well WDM DFB laser and is a class1 laser compliant according to International Safety Standard IEC-60825. The receiver section uses an integrated InGaAs detector preamplifier (IDP) mounted in an optical header and a limiting post-amplifier IC.

A PECL logic interface simplifies interface to the external circuitry.

Eoptolink

Absolute Maximum Ratings

Parameter	Symbol	Min.	Max.	Unit	
Storage Temperature	T_s	-40	+85	°C	
Supply Voltage	V_{CC}	5V	-0.5	7.0	V
		3.3V	-0.5	5.5	
Operating Relative Humidity	-		95	%	
Soldering Conditions Temp/Time			260/10	°C/s	

*Exceeding any one of these values may destroy the device immediately.

Recommended Operating Conditions

Parameter	Symbol	Min.	Typical	Max.	Unit
Operating Case Temperature	T_A	0		+70	°C
Power Supply Voltage	V_{CC}	4.75	5	5.25	V
		3.15	3.3	3.45	
Power Supply Current ^{*(note4)}	I_{CC}			300	mA
Data Rate			155		Mbps

Note4: Maximum current is specified at V_{CC} equaling to Maximum @ maximum temperature.

Optical and Electrical Characteristic

(EOL9-1603-80 Series, DFB and PIN)

Parameter	Symbol	Min.	Typical	Max.	Unit
Data Rate			155		Mbps
Link Budget		34			dB
Transmitter					
Centre Wavelength	λ_C	$\lambda_C - 5.5$	λ_C	$\lambda_C + 7.5$	nm
Spectral Width(-20dBm)	$\Delta\lambda$			1	nm
Average Output Power ^{*(note5)}	P_{out}	0		+5	dBm
Extinction Ratio	ER	9			dB
Rise/Fall Time (20%---80%)	tr/tf			2	ns
Relative Intensity Noise	RIN			-117	dB/Hz
Total Jitter	TJ			1	ns
Data Input Swing Differential	V_{in}	400		2000	mV
Input Differential Impedance	Z_{in}	90	100	110	Ω
Input High Voltage	V_H	-1165		-880	mV
Input Low Voltage	V_L	-1810		-1475	mV
Eye Diagram	IUT-T G.957 Compliant ^{*(note7)}				
Data Input	PECL ^{*(note1)}				
Receiver					
Input center wavelength	λ_C	1260		1620	nm
Receiver Sensitivity ^{*(note6)}	P_{min}			-34	dBm

Receiver Overload	Pmax	-5			dBm
SD Assert	SDA			-35	dBm
SD De-Assert	SDD	-45			dBm
SD Hysteresis ^{*(note8)}		0.5			dB
Output High Voltage	V _H	-1165		-880	mV
Output Low Voltage	V _L	-1810		-1475	mV
SD Voltage(TTL-H) ^{*(note1)}	V _H	2			V
SD Voltage (TTL-L) ^{*(note1)}	V _L			0.8	V
SD Voltage(PECL-H) ^{*(note1)}	V _H	-1.1		-0.74	V
SD Voltage (PECL-L) ^{*(note1)}	V _L	-2.0		-1.58	V
Data Output	PECL ^{*(note1)}				

Note5: The optical power is launched into 9/125um SMF.

Note6: Minimum average optical power measured at BER less than 1E-12, with a 2²³-1 PRBS and ER=9 dB.

Note7: Eye pattern mask

Note8: LOS Hysteresis

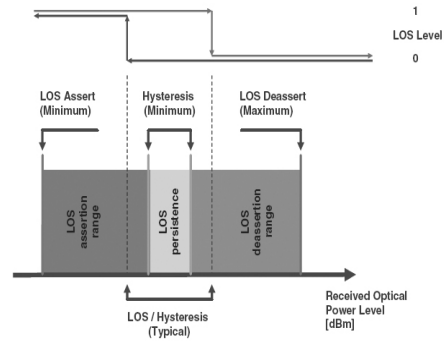
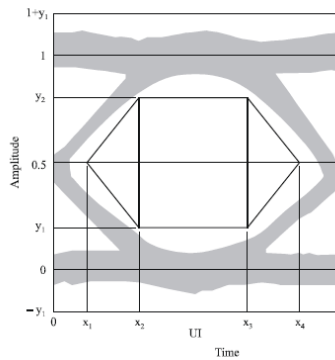

Pin Description

Pin	Name	Level	Description
1	Veer		Receiver Signal Ground, connect to receiver signal ground plane directly
2	RD+	PECL ^{*(note1)}	Receiver data out
3	RD-	PECL ^{*(note1)}	Inverted receiver data out
4	SD	PECL ^{*(note1)}	Signal Detect, TTL (Load resistor > 4.7KΩ) or PECL output, Normal optical input levels to the receiver result in a logic "1" output, asserted. Low input levels to the receiver result in a fault condition indicated by a logic "0" output, de-asserted.
5	Vccr		Receiver Power Supply, provide +5V (+3.3V) the recommended receiver power supply filter circuit. Locate the power filter circuit as close as possible to the Vccr pin
6	Vcct		Transmitter Power Supply, provide +5V DC(+3.3V) via the recommended transmitter power supply filter circuit. Locate the power filter circuit as close as possible to the Vcct pin
7	TD-	PECL ^{*(note1)}	Inverted transmitter Data in
8	TD+	PECL ^{*(note1)}	Transmitter Data in

9	Veet		Transmitter Signal Ground, connect to the transmitter signal ground planed directly
---	------	--	---

Pin Definitions

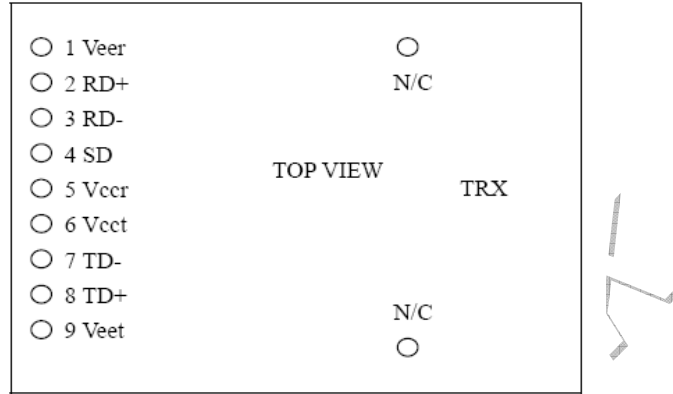

Recommended Circuit

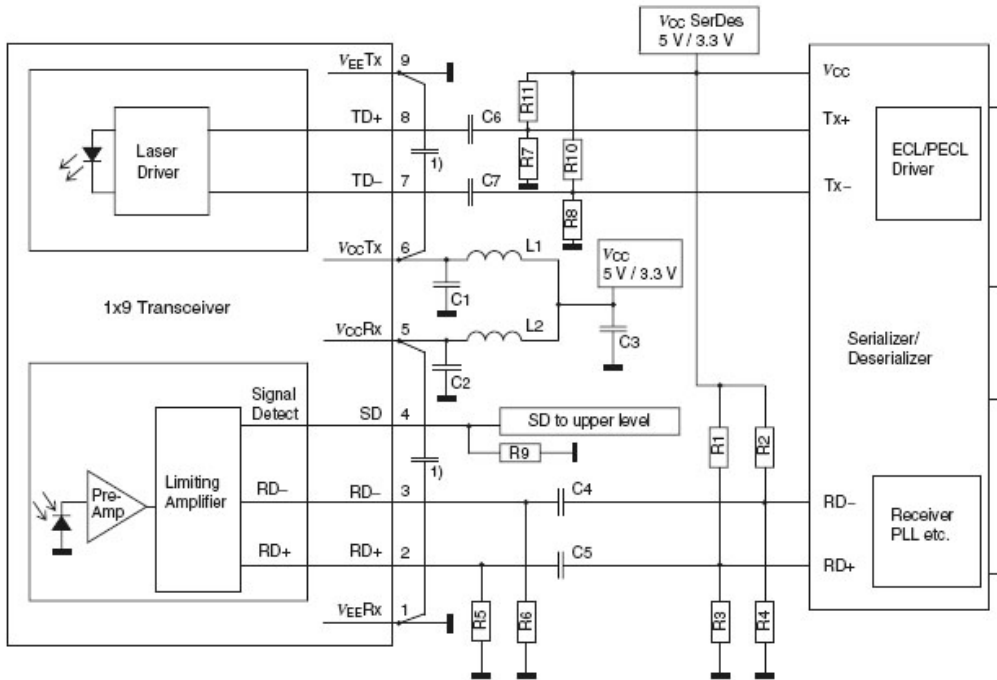

- C1/2/3 = 4.7 μ F
- C4/5/6/7 = 100 nF
- L1/2 = 1 μ H
- R5/6 = 270 Ω (5 V)
- = 150 Ω (3.3 V)
- R7/8 = 127 Ω (5 V)
- = 82 Ω (3.3 V)
- (depends on SerDes chip used)
- R9 = 510 Ω (5 V)
- = 270 Ω (3.3 V)

- R10/11 = 82 Ω (5 V)
- = 127 Ω (3.3 V)
- (depends on SerDes chip used)
- Place R1/2/3/4 close to SerDes chip, depends on SerDes chip used.
- Place R5/6/7/8/10/11 close to 1x9 transceiver.

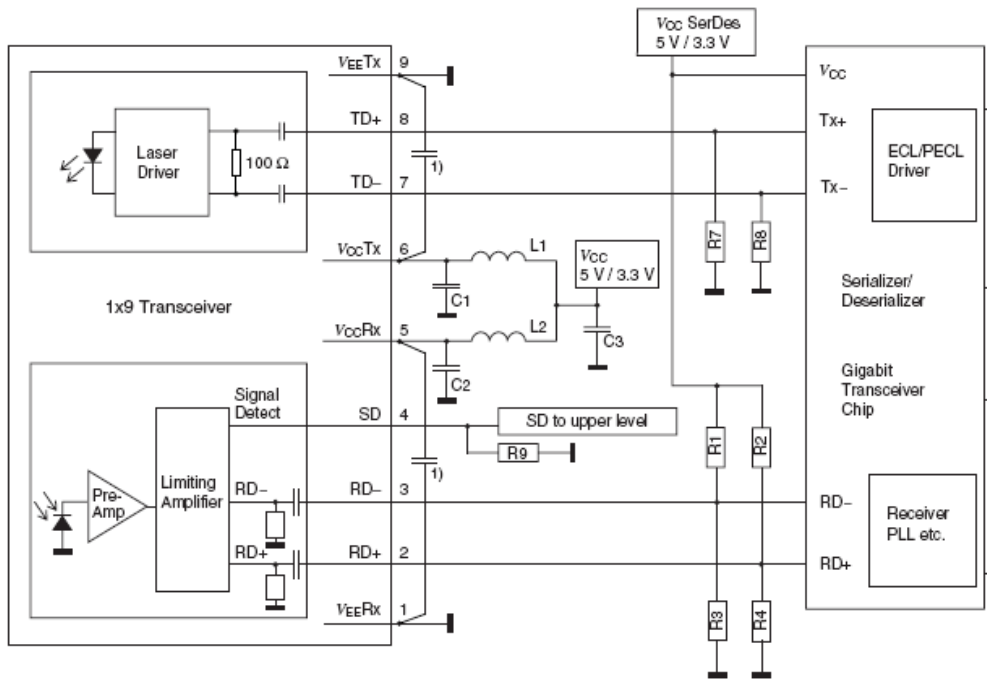

- C1/2/3 = 4.7 μ F
- L1/2 = 1 μ H
- R1/2/3/4 = Depends on SerDes chip used
- R7/8 = Biasing (depends on SerDes chip)
- R9 = open (5 V/3.3 V TTL)
- = 510 Ω (5 V PECL)
- = 270 Ω (3.3 V PECL)

Place R1/2/3/4/7/8 close to SerDes chip.
Place R5/6 close to 1x9 transceiver.

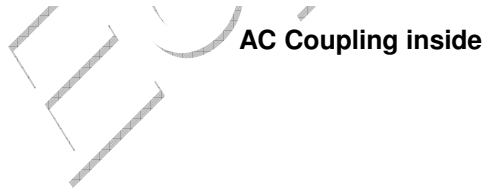

Package outline (Unit: mm)

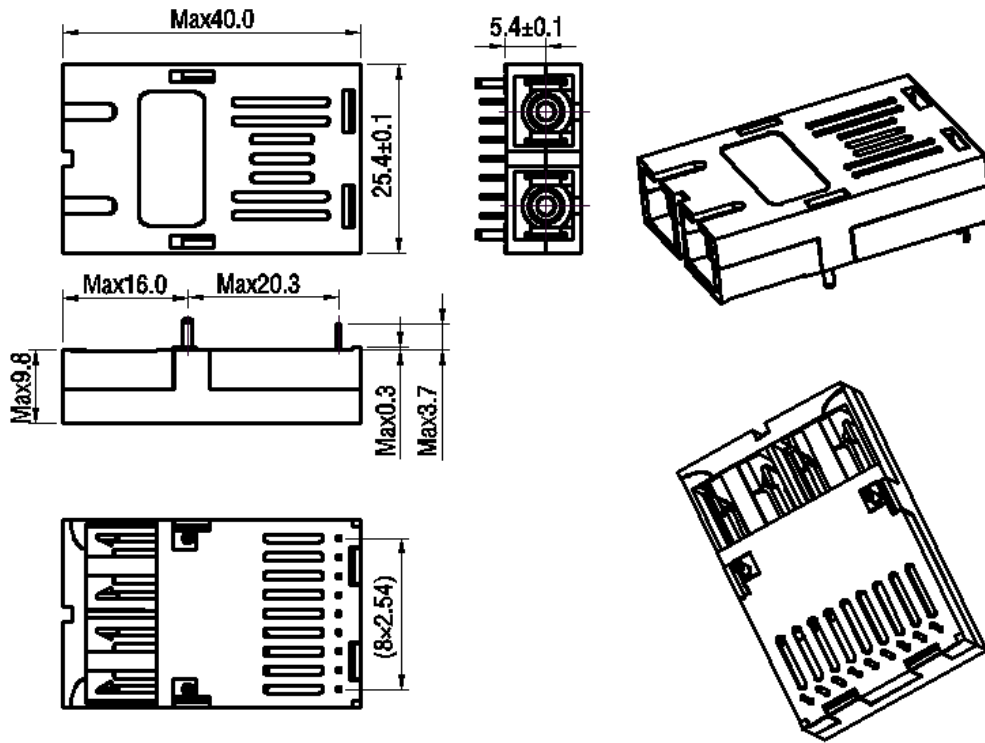

SC receptacle

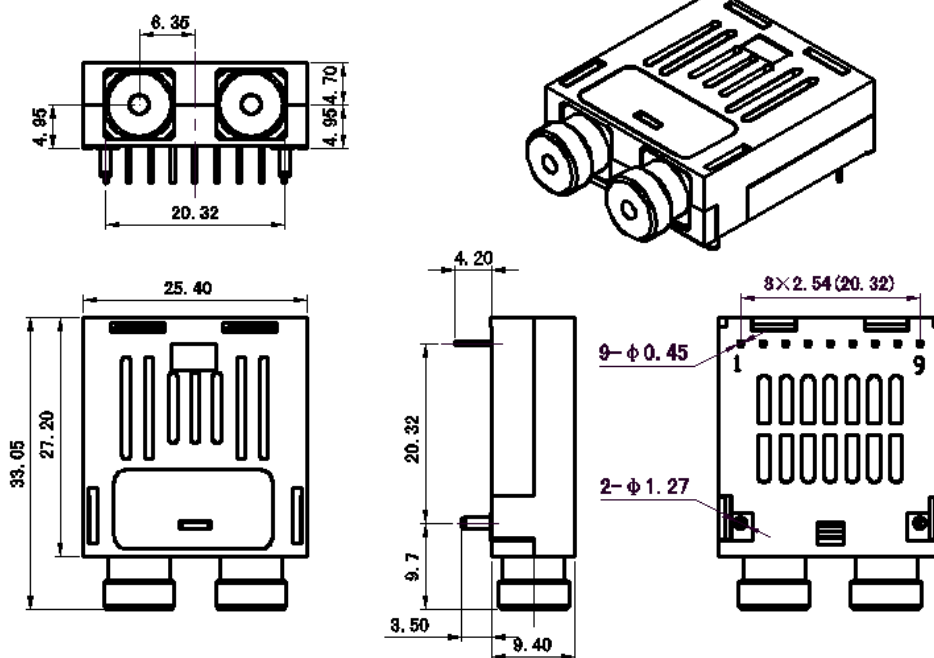

FC receptacle

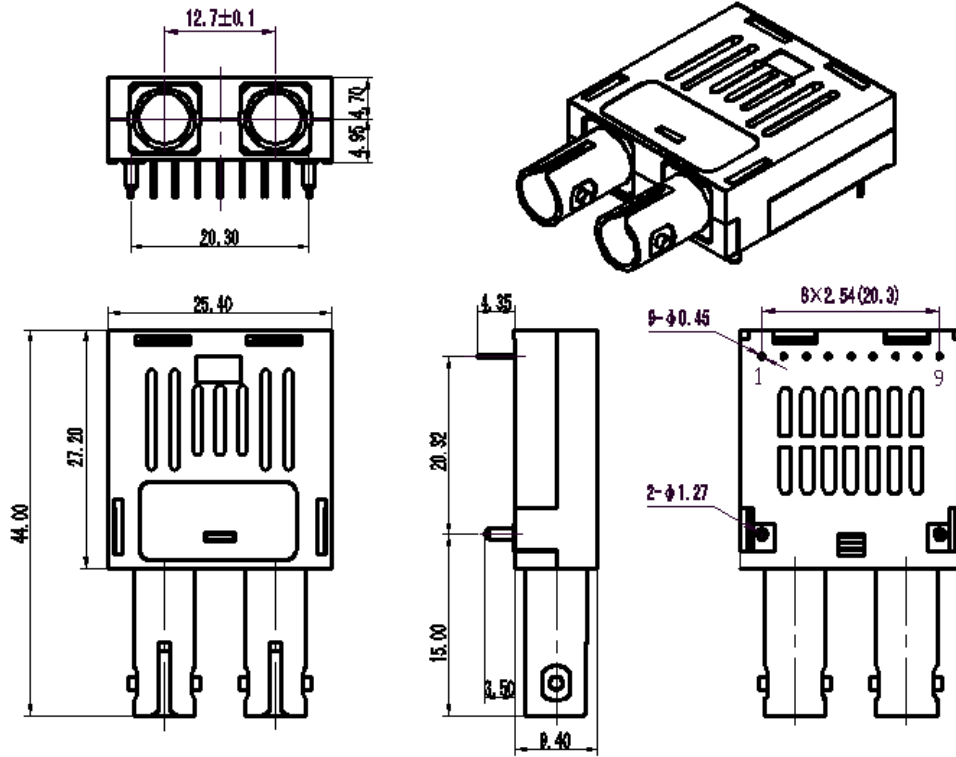

ST receptacle

Class 1 Labels

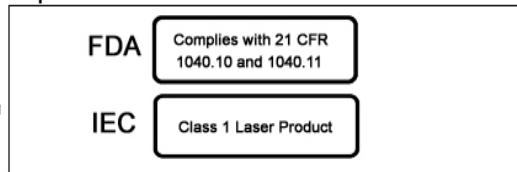

Laser Emission Data

Wavelength	>1460nm
Total output power (as defined by FDA: 7 mm aperture at 20 cm distance)	<0.79mW
Total output power (as defined by IEC: 7 mm aperture at 10 cm distance)	<10mW
Beam divergence	12.5°

Laser Emission

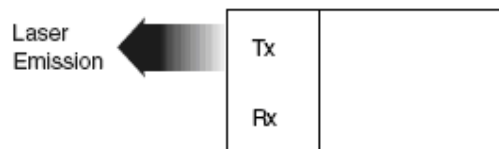

Obtaining Document

You can visit our website:

<http://www.eoptolink.com>

Or contact Eoptolink Technology Inc., Ltd. listed at the end of the documentation to get the latest documentation.

Revision History

Revision	Initiated	Reviewed	Approved	DCN	Release Date
V2.a	Tim.Liang	Kelly		Released.	Jan 12, 2008
V2.b	Kelly			Change logo.	Jan 12, 2010

Notice:

Eoptolink reserves the right to make changes or discontinue any product or service identified in this publication, without notice, in order to improve design and/or performance. Applications that are described herein for any of the products are for illustrative purposes only. Eoptolink makes no representation or warranty that such applications will be suitable for the specified use without further testing or modification.

Contact:

Add: Floor 5 Building 2 No. 21 Gaopeng Avenue High-Tech District CHENGDU, SICHUAN 610041
P.R. CHINA

Tel: (+86) 028-85122709 ext 816 & 809

Fax: (+86) 028-85121912

Postal: 610041

E-mail:sales@eoptolink.com

<http://www.eoptolink.com>