

## EOLP-1696-23X

**CWDM SFP+ Single-Mode for 10GbE & 2/4/8/10GFC  
Duplex SFP+ Transceiver  
RoHS6 Compliant**



### Features

- ◆ Supports 9.95Gb/s to 10.3Gb/s Bit Rates
- ◆ Hot-Pluggable SFP+ Footprint
- ◆ 4-Wavelengths CWDM DFB Transmitter from 1270nm to 1330nm, with step 20nm
- ◆ High Sensitivity APD for Receiver
- ◆ 23dB Power Budget
- ◆ Duplex LC connector
- ◆ Case Operation Temperature Range -5°C to 70°C
- ◆ Compliant with SFP+ MSA Specification SFF-8431
- ◆ Build-in Digital Diagnostic Functions Compliant with SFF-8472 MSA Specification

### Applications

- ◆ 10GBASE-ER/EW 10G Ethernet
- ◆ 10 X Fiber Channel
- ◆ 10GBASE-ZR at 10.31Gbps
- ◆ 10GBASE-ZW at 9.95Gbps
- ◆ 1000 Base-LX Ethernet
- ◆ 8XFC at 8.5Gbps
- ◆ 4XFC at 4.25Gbps
- ◆ 2XFC at 2.125Gbps

### Ordering information

Part No.	Data Rate	Laser	Fiber	Power Budget	Interface
EOLP-1696-23X <sup>*(note1)</sup>	10G	CWDM DFB	SMF	23dB	LC

Note1: X refers to CWDM Wavelength range 1270nm to 1330nm, X=A~D, denotes 1270nm to 1330nm.

**CWDM\* Wavelength (0C~70C)**

Band	Nomenclature	Wavelength(nm)		
		Min.	Typ.	Max.
O-band Original	A	1264	1270	1277.5
	B	1284	1290	1297.5
	C	1304	1310	1317.5
	D	1324	1330	1337.5

CWDM\*: 4 Wavelengths from 1270nm to 1330nm, each step 20nm.

**Regulatory Compliance**

Feature	Standard	Performance
Electrostatic Discharge (ESD) to the Electrical Pins	MIL-STD-883G Method 3015.7	Class 1C (>1000 V)
Electrostatic Discharge to the Enclosure	EN 55024:1998+A1+A2 IEC-61000-4-2 GR-1089-CORE	Compliant with standards
Electromagnetic Interference (EMI)	FCC Part 15 Class B EN55022: 2006 CISPR 22B: 2006 VCCI Class B	Compliant with standards Noise frequency range: 30MHz to 6GHz. Good system EMI design practice required to achieve Class B margins. System margins are dependent on customer host board and chassis design.
Immunity	EN 55024:1998+A1+A2 IEC 61000-4-3	Compliant with standards. 1KHz sine-wave, 80% AM, from 80MHz to 1GHz. No effect on transmitter/receiver performance is detectable between these limits.
Laser Eye Safety	FDA 21CFR 1040.10 and 1040.11 EN (IEC) 60825-1: 2007 EN (IEC) 60825-2: 2004+A1	CDRH compliant and Class I laser product. TüV Certificate No. 50135086
Component Recognition	UL and CUL EN60950-1: 2006	UL file E317337 TüV Certificate No. 50135086 (CB scheme )
RoHS6	2002/95/EC 4.1&4.2 2005/747/EC 5&7&13	Compliant with standards <sup>*note3</sup>

Note2: For update of the equipments and strict control of raw materials, EOPTOLINK has the ability to supply the customized products since Jan 1<sup>st</sup>, 2007, which meet the requirements of RoHS6 (Restrictions on use of certain Hazardous Substances) of European Union.

In light of item 5 in RoHS exemption list of RoHS Directive 2002/95/EC, Item 5: Lead in glass of cathode ray tubes, electronic components and fluorescent tubes.

In light of item 13 in RoHS exemption list of RoHS Directive 2005/747/EC, Item 13: Lead and cadmium in optical and filter glass. The three exemptions are being concerned for Eoptolink's transceivers, because Eoptolink's transceivers use glass, which may contain Pb, for components such as lenses, solators, and other components.

## Product Description

The EOLP-1696-23X series optical transceiver is designed for fiber communications application such as 10G Ethernet (10GBASE-ZR/ZW) or Fiber Channel, which fully compliant with the specification of SFP+ MSA SFF-8431.

This module is designed for single mode fiber and operates at a nominal wavelength of CWDM wavelength. There are four center wavelengths available from 1270nm to 1330nm, with each step 20nm. A guaranteed optical link budget of 23 dB is offered.

The module is with the SFP+ connector to allow hot plug capability. Only single 3.3V power supply is needed. The optical output can be disabled by LVTTTL logic high-level input of TX\_DIS. Loss of signal (RX\_LOS) output is provided to indicate the loss of an input optical signal of receiver.

This module provides digital diagnostic functions via a 2-wire serial interface as defined by the SFF-8472 specification.

## Absolute Maximum Ratings

Parameter	Symbol	Min	Typical	Max	Unit	Note
Maximum Supply Voltage 1	V <sub>CC</sub>	-0.5		4.0	V	
Storage Temperature	T <sub>S</sub>	-40		85	°C	
Case Operating Temperature	T <sub>OP</sub>	-5		70	°C	

## Recommend Operating Condition

Parameter	Symbol	Min	Typical	Max	Units	Note
Case Operating Temperature	T <sub>OP</sub>	-5		70	°C	
Supply Voltage	V <sub>CC</sub>	3.13	3.3	3.45	V	
Supply Current	I <sub>CC</sub>			660	mA	
Data Rate		9.95		10.3125	Gbps	

## Electrical Characteristics

(T<sub>OP</sub> = -5 to 70°C, V<sub>CC</sub> = 3.15 to 3.45V)

Parameter	Symbol	Min.	Typ.	Max	Unit	Notes
-----------	--------	------	------	-----	------	-------

Transmitter						
CML Inputs(Differential)	V <sub>in</sub>	180		1000	mVpp	1
Input Impedance (Differential)	Z <sub>in</sub>	85	100	115	ohm	
TX_DISABLE Input Voltage - High		2		V <sub>cc</sub> +0.3	V	
TX_DISABLE Input Voltage - Low		0		0.8	V	
TX_FAULT Output Voltage - High		2		V <sub>cc</sub> +0.3	V	
TX_FAULT Output Voltage - Low		0		0.8	V	
Receiver						
CML Outputs (Differential)	V <sub>out</sub>	350		700	mVpp	1
Output Impedance (Differential)	Z <sub>out</sub>	85	100	115	ohm	
RX_LOS Output Voltage - High		2		V <sub>cc</sub> +0.3	V	
RX_LOS Output Voltage - Low		0		0.8	V	
MOD_DEF ( 0:2 )	VoH	2.5			V	2
	VoL	0		0.5	V	

## Notes:

1. After internal AC coupling.
2. Reference the SFF-8472 MSA.

## Optical Characteristics

(T<sub>OP</sub> = -5 to 70°C, V<sub>CC</sub> = 3.15 to 3.45V)

Parameter	Symbol	Min	Typical	Max	Unit	Note
Transmitter						
Output Opt. Pwr: 9/125 SMF	P <sub>out</sub>	0		+4	dBm	1
Optical Extinction Ratio	ER	3.5			dB	
Optical Wavelength	λ	λ <sub>c</sub> -6	λ <sub>c</sub>	λ <sub>c</sub> +7.5	nm	2
-20dB Spectrum Width	Δλ			1	nm	
Side Mode Suppression Ratio	SMSR	30			dB	
Average Launch Power of OFF Transmitter	P <sub>OFF</sub>			-30	dBm	
TX Jitter	TXj	Per 802.3ae requirements				

Relative Intensity Noise	RIN			-128	dB/Hz	
<b>Receiver</b>						
Receiver Sensitivity @ 10.3125Gb/s	Pmin			-23	dBm	3
Maximum Input Power	Pmax	+0.5			dBm	
Optical Center Wavelength	$\lambda$	1260		1600	nm	
Receiver Reflectance	Rrf			-12	dB	
LOS De-Assert	LOS <sub>D</sub>			-23	dBm	
LOS Assert	LOS <sub>A</sub>	-33			dBm	
LOS Hysteresis		1			dB	

**Notes:**

1. Output power is coupled into a 9/125 $\mu$ m SMF.
2. ITU-T G.694.2 CWDM wavelength from 1270nm to 1330nm, each step 20nm.
3. Average received power; BER less than 1E-12 and PRBS 2<sup>31</sup>-1 test pattern.

## SFP+ Transceiver Electrical Pad Layout

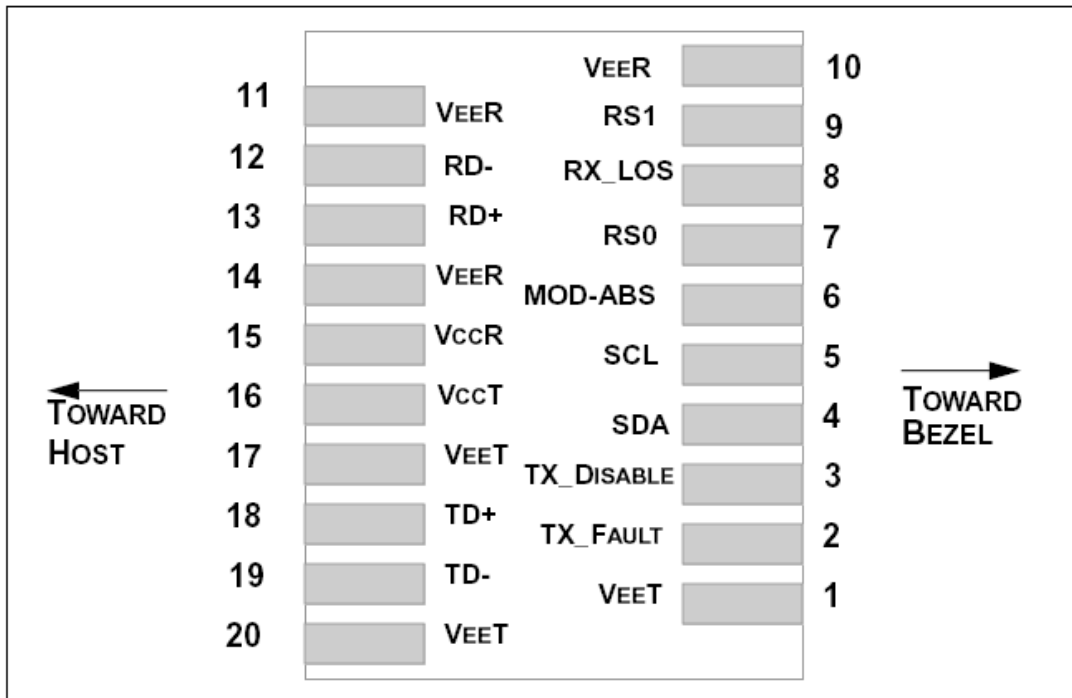

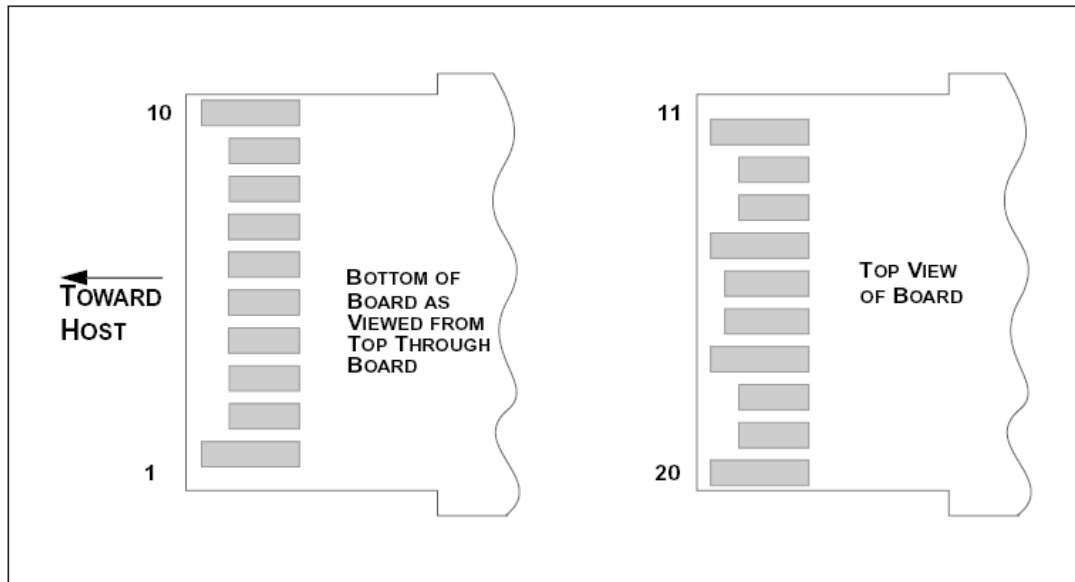

## Pin Function Definitions

Pin Num.	Name	Function	Plug Seq.	Notes
1	VeeT	Transmitter Ground	1	Note 5
2	TX Fault	Transmitter Fault Indication	3	Note 1
3	TX Disable	Transmitter Disable	3	Note 2, Module disables on high or open
4	SDA	Module Definition 2	3	Note 3, Data line for Serial ID.
5	SCL	Module Definition 1	3	Note 3, Clock line for Serial ID.
6	MOD-ABS	Module Definition 0	3	Note 3
7	RS0	RX Rate Select (LVTTTL).	3	This pin has an internal 30k pull down to ground. A signal on this pin will not affect module performance.
8	LOS	Loss of Signal	3	Note 4
9	RS1	TX Rate Select (LVTTTL).	1	This pin has an internal 30k pull down to ground. A signal on this pin will not affect module performance.
10	VeeR	Receiver Ground	1	Note 5

11	VeeR	Receiver Ground	1	Note 5
12	RD-	Inv. Received Data Out	3	Note 6
13	RD+	Received Data Out	3	Note 6
14	VeeR	Receiver Ground	1	Note 5
15	VccR	Receiver Power	2	3.3 ± 5%, Note 7
16	VccT	Transmitter Power	2	3.3 ± 5%, Note 7
17	VeeT	Transmitter Ground	1	Note 5
18	TD+	Transmit Data In	3	Note 8
19	TD-	Inv. Transmit Data In	3	Note 8
20	VeeT	Transmitter Ground	1	Note 5

### Notes:

1) TX Fault is an open collector/drain output, which should be pulled up with a 4.7K – 10KΩ resistor on the host board. Pull up voltage between 2.0V and VccT, R+0.3V. When high, output indicates a laser fault of some kind. Low indicates normal operation. In the low state, the output will be pulled to < 0.8V.

2) TX disable is an input that is used to shut down the transmitter optical output. It is pulled up within the module with a 4.7~10 K Ω resistor. Its states are:

Low (0 – 0.8V): Transmitter on

(>0.8, < 2.0V): Undefined

High (2.0 – 3.465V): Transmitter Disabled

Open: Transmitter Disabled

3) Modulation Absent, connected to VEET or VEER in the module.

4) LOS (Loss of Signal) is an open collector/drain output, which should be pulled up with a 4.7K – 10KΩ resistor on host board. Pull up voltage between 2.0V and VccT, R+0.3V. When high, this output indicates the received optical power is below the worst-case receiver sensitivity (as defined by the standard in use). Low indicates normal operation. In the low state, the output will be pulled to < 0.8V.

5) VeeR and VeeT may be internally connected within the SFP+ module.

6) RD-/+ : These are the differential receiver outputs. They are AC coupled 100Ω differential lines which should be terminated with 100Ω (differential) at the user SERDES. The AC coupling is done inside the module and is thus not required on the host board. The voltage swing on these lines will be between 370 and 700 mV differential (185 –350mV single ended) when properly

terminated.

7) VccR and VccT are the receiver and transmitter power supplies. They are defined as 3.3V  $\pm 5\%$  at the SFP+ connector pin. Maximum supply current is 300mA. Recommended host board power supply filtering is shown below. Inductors with DC resistance of less than 1 ohm should be used in order to maintain the required voltage at the SFP+ input pin with 3.3V supply voltage. When the recommended supply-filtering network is used, hot plugging of the SFP+ transceiver module will result in an inrush current of no more than 30mA greater than the steady state value. VccR and VccT may be internally connected within the SFP+ transceiver module.

8) TD-/+ : These are the differential transmitter inputs. They are AC-coupled, differential lines with 100 $\Omega$  differential termination inside the module. The AC coupling is done inside the module and is thus not required on the host board.

## EEPROM

The serial interface uses the 2-wire serial CMOS EEPROM protocol defined for the ATMEL AT24C02/04 family of components. When the serial protocol is activated, the host generates the serial clock signal (SCL). The serial data signal (SDA) is bi-directional for serial data transfer. The host uses SDA in conjunction with SCL to mark the start and end of serial protocol activation. The memories are organized as a series of 8-bit data words that can be addressed individually or sequentially.

The Module provides diagnostic information about the present operating conditions. The transceiver generates this diagnostic data by digitization of internal analog signals. Calibration and alarm/warning threshold data is written during device manufacture. Received power monitoring, transmitted power monitoring, bias current monitoring, supply voltage monitoring and temperature monitoring all are implemented. If the module is defined as external calibrated, the diagnostic data are raw A/D values and must be converted to real world units using calibration constants stored in EEPROM locations 56 – 95 at wire serial bus address A2H. The digital diagnostic memory map specific data field define as following .For detail EEPROM information, please refer to the related document of SFF 8472 Rev 10.3.

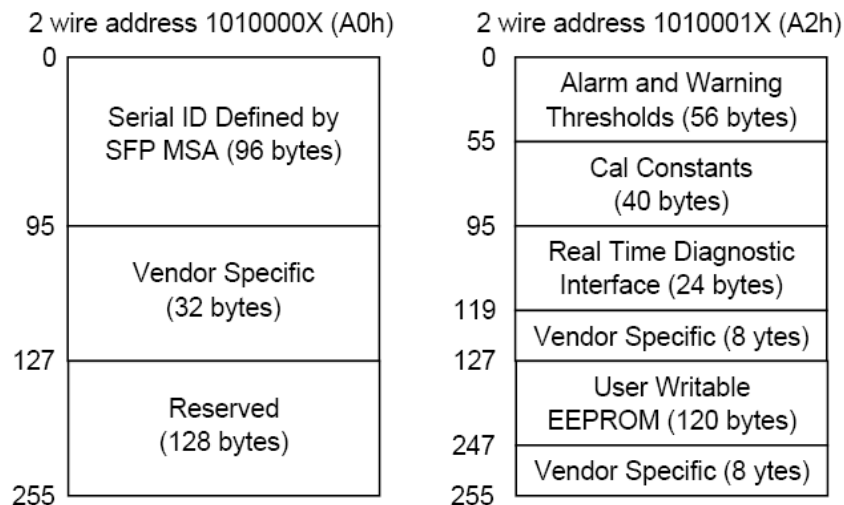

Recommend Circuit Schematic

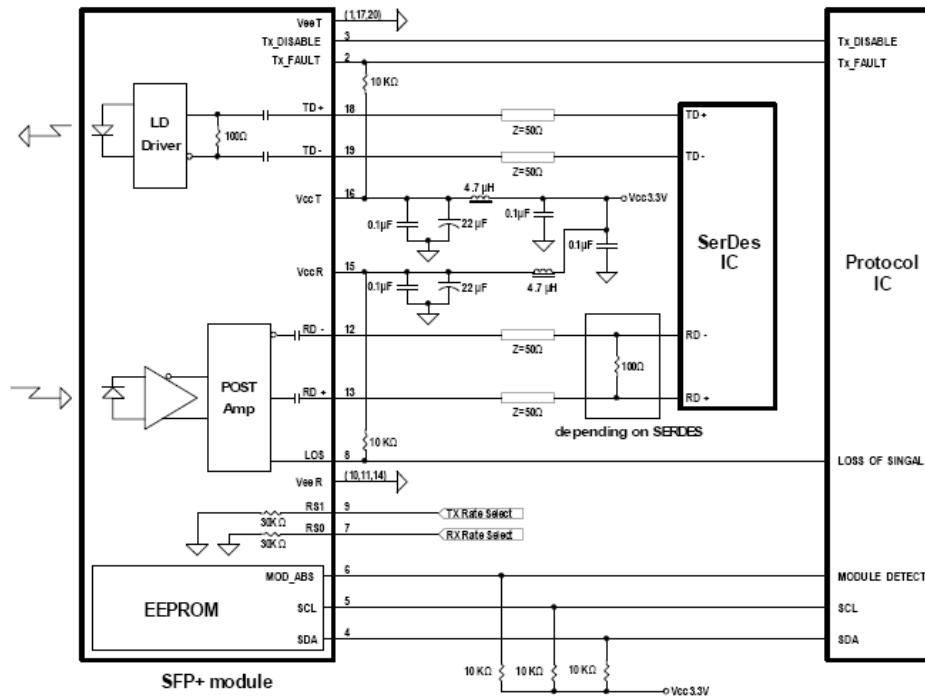

Mechanical Specifications

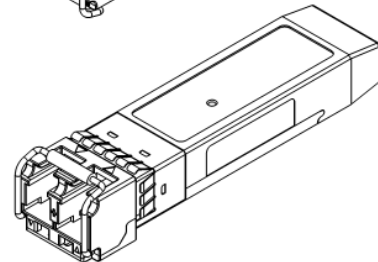
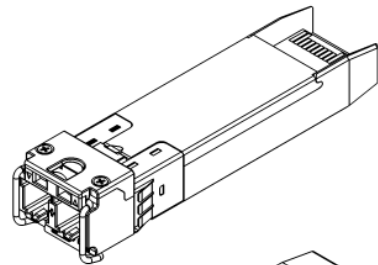
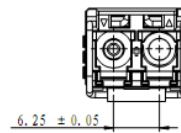
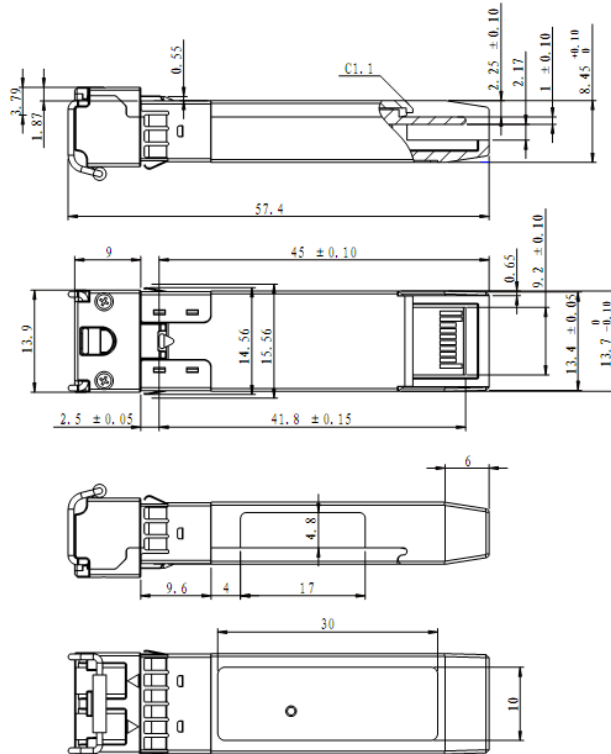

## Eye Safety

This single-mode transceiver is a Class 1 laser product. It complies with IEC-60825 and FDA 21 CFR 1040.10 and 1040.11. The transceiver must be operated within the specified temperature and voltage limits. The optical ports of the module shall be terminated with an optical connector or with a dust plug.

## Obtaining Document

You can visit our website: <http://www.eoptolink.com>

Or contact Eoptolink Technology Inc., Ltd. Listed at the end of the documentation to get the latest documents.

## Revision History

Revision	Initiate	Review	Approve	Revision History	Release Date
V1.a	Cathy			Released.	November 22, 2010
V1.b	Kelly			Delete redundant wavelength.	June 13, 2011

## Notice:

Eoptolink reserves the right to make changes to or discontinue any optical link product or service identified in this publication, without notice, in order to improve design and/or performance. Applications that are described herein for any of the optical link products are for illustrative purposes only. Eoptolink makes no representation or warranty that such applications will be suitable for the specified use without further testing or modification.

## Contact:

Add: Floor 5, Building 2, No. 21 Gaopeng Avenue, High-Tech District, CHENGDU, SICHUAN  
610041 P.R. CHINA

Tel: (+86) 028-85122709 ext 808 & 809

Fax: (+86) 028-85121912

Postal: 610041

E-mail: [sales@eoptolink.com](mailto:sales@eoptolink.com)

<http://www.eoptolink.com>