

## EOLS-1603-40-X Series

Single-Mode CWDM SFP 155M SDH/SONET or 100M FE  
 Duplex SFP Transceiver  
 RoHS6 Compliant

### Features

- ◆ Operating Data Rate up to 155Mbps
- ◆ 18-Wavelength CWDM DFB LD Transmitter from 1270nm to 1610nm, with step 20nm
- ◆ 40km transmission over SMF at Least, 29dB
- ◆ Single 3.3V Power Supply and TTL Logic Interface
- ◆ Hot-Pluggable SFP Footprint Duplex LC Connector Interface
- ◆ Compliant with Class 1 FDA and IEC60825-1 Laser Safety
- ◆ Operating Case Temperature Standard: 0°C~+70°C
- ◆ Compliant with SFP MSA
- ◆ Compliant with SFF-8472



### Applications

- ◆ SDH/SONET
- ◆ ATM Switches and Routers
- ◆ Fast Ethernet
- ◆ Other Optical Link

### Ordering Information

Part No.	Data Rate	Fibre	Distance <sup>*(note2)</sup>	Interface	Temperature	DDMI
EOLS-1603-40-X <sup>*(note1)</sup>	155/100Mbps	SMF	40km	LC	Standard	NO
EOLS-1603-40-XD	155/100Mbps	SMF	40km	LC	Standard	YES

Note1: X refers to CWDM Wavelength range 1270nm to 1610nm, A=27, B=29, ...,Q=59, R=61.

Note2: 40km transmission with 9/125µm SMF at least.

### CWDM\* Wavelength(0~70°C)

Band	Nomenclature	Wavelength(nm)		
		Min.	Typ.	Max.
O-band Original	A	1264	1270	1277.5
	B	1284	1290	1297.5

	C	1304	1310	1317.5
	D	1324	1330	1337.5
	E	1344	1350	1357.5
E-band Extended	F	1364	1370	1377.5
	G	1384	1390	1397.5
	H	1404	1410	1417.5
	I	1424	1430	1437.5
	J	1444	1450	1457.5
S-band Short Wavelength	K	1464	1470	1477.5
	L	1484	1490	1497.5
	M	1504	1510	1517.5
	N	1524	1530	1537.5
C-band Conventional	O	1544	1550	1557.5
L-band Long Wavelength	P	1564	1570	1577.5
	Q	1584	1590	1597.5
	R	1604	1610	1617.5

CWDM\*: 18 Wavelengths from 1270 nm to 1610 nm, with 20 nm span.

### Regulatory Compliance

Feature	Standard	Performance
Electrostatic Discharge (ESD) to the Electrical Pins	MIL-STD-883G Method 3015.7	Class 1C (>1000V)
Electrostatic Discharge to the Enclosure	EN 55024:1998+A1+A2 IEC-61000-4-2 GR-1089-CORE	Compliant with standards
Electromagnetic Interference (EMI)	FCC Part 15 Class B EN55022:2006 CISPR 22B :2006 VCCI Class B	Compliant with standards Noise frequency range: 30MHz to 6GHz. Good system EMI design practice required to achieve Class B margins. System margins are dependent on customer host board and chassis design.
Immunity	EN 55024:1998+A1+A2 IEC 61000-4-3	Compliant with standards. 1KHz sine-wave, 80% AM, from 80MHz to 1GHz. No effect on

		transmitter/receiver performance is detectable between these limits.
Laser Eye Safety	FDA 21CFR 1040.10 and 1040.11 EN (IEC) 60825-1:2007 EN (IEC) 60825-2:2004+A1	CDRH compliant and Class I laser product. TüV Certificate No. 50135086
Component Recognition	UL and CUL EN60950-1:2006	UL file E317337 TüV Certificate No. 50135086 (CB scheme )
RoHS6	2002/95/EC 4.1&4.2 2005/747/EC 5&7&13	Compliant with standards <sup>*note3</sup>

Note3: For update of the equipments and strict control of raw materials, EOPTOLINK has the ability to supply the customized products since Jan 1, 2007, which meet the requirements of RoHS6 (Restrictions on use of certain Hazardous Substances) of European Union.

In light of item 5 in RoHS exemption list of RoHS Directive 2002/95/EC, Item 5: Lead in glass of cathode ray tubes, electronic components and fluorescent tubes.

In light of item 13 in RoHS exemption list of RoHS Directive 2005/747/EC, Item13: Lead and cadmium in optical and filter glass. The three exemptions are being concerned for Eoptolink's transceivers, because Eoptolink's transceivers use glass, which may contain Pb, for components such as lenses, windows, isolators, and other electronic components.

### Product Description

The EOLS-1603-40-X series single mode transceiver is small form factor pluggable module for serial optical data communications such as SONET OC-3 / SDH STM-1 and Fast Ethernet. It is with the SFP 20-pin connector to allow hot plug capability. This module is designed for single mode fiber and operates at a nominal wavelength of CWDM. There are eighteen center wavelengths available from 1270nm to 1610nm, with each step 20nm. A guaranteed minimum power budget of 29dB is offered.

The transmitter section uses a multiple quantum well CWDM DFB laser and is a class 1 laser compliant according to International Safety Standard IEC-60825. The receiver section uses an integrated InGaAs avalanche photodiode preamplifier (IDP) mounted in an optical header and a limiting post-amplifier IC.

The EOLS-1603-40-XD series are designed to be compliant with SFF-8472.

### Absolute Maximum Ratings

Parameter	Symbol	Min.	Max.	Unit
Storage Temperature	T <sub>S</sub>	-40	+85	°C
Operating Case Temperature	T <sub>case</sub>	0	75	°C
Supply Voltage	V <sub>CC</sub>	-0.5	3.6	V
Operating Relative Humidity		-	95	%

\*Exceeding any one of these values may destroy the device permanently.

## Recommended Operating Conditions

Parameter	Symbol	Min.	Typical	Max.	Unit
Operating Case Temperature	$T_A$ EOLS-1603-X	0		+70	°C
Power Supply Voltage	$V_{CC}$	3.15	3.3	3.45	V
Power Supply Current	$I_{CC}$			300	mA
Date Rate	OC-3/STM-1		155		Mbps
	100M		100		

## Performance Specifications - Electrical

Parameter	Symbol	Min.	Typ.	Max	Unit	Notes
<b>Transmitter</b>						
LVPECL Inputs(Differential)	$V_{in}$	400		2000	mVpp	AC coupled inputs*(note4)
Input Impedance (Differential)	$Z_{in}$	85	100	115	ohm	$R_{in} > 100$ kohm @ DC
TX_Dis	Disable	2		$V_{CC}$	V	
	Enable	0		0.8		
TX_FAULT	Fault	2		$V_{CC}$	V	
	Normal	0		0.8		
<b>Receiver</b>						
LVPECL Outputs (Differential)	$V_{out}$	370		2000	mVpp	AC coupled outputs*(note4)
Output Impedance (Differential)	$Z_{out}$	85	100	115	ohm	
RX_LOS	LOS	2		$V_{CC}$	V	
	Normal	0		0.8	V	
MOD_DEF ( 0:2 )	VoH	2.5			V	
	VoL	0		0.8	V	

## Performance Specifications - Optical

(CWDM DFB and PIN/TIA, 29dB Power Budget at Least)

Parameter	Symbol	Min.	Typical	Max.	Unit
Data Rate			100/155		Mbps
<b>Transmitter</b>					
Center Wavelength	$\lambda_C$	$\lambda_C - 6$	$\lambda_C$	$\lambda_C + 7.5$	nm
Spectral Width (-20dB)	$\Delta\lambda$			1	nm
Average Output Power*(note5)	$P_{out}$	-5		0	dBm
Extinction Ratio*(note6)	ER	10			dB
Side Mode Suppression Ratio	SMSR	30			dB
Rise/Fall Time(20%~80%)	tr/tf			2	ns

Output Optical Eye <sup>*(note6)</sup>	IUT-T G.957 Compliant <sup>*(note9)</sup>				
TX_Disable Assert Time	t_off			10	us
<b>Receiver</b>					
Center Wavelength	$\lambda_C$	1260		1600	nm
Receiver Sensitivity <sup>*(note7)</sup>	Pmin			-34	dBm
Receiver Overload	Pmax	-10			dBm
Return Loss		14			dB
Optical Path Penalty <sup>*(note8)</sup>				1	dB
LOS De-Assert	LOSD			-35	dBm
LOS Assert	LOSA	-45			dBm
LOS Hysteresis <sup>*(note10)</sup>		0.5			dB

Note4: LVPECL logic, internally AC coupled.

Note5: Output is coupled into a 9/125 $\mu$ m single-mode fiber.

Note6: Filtered, measured with a PRBS 2<sup>23</sup>-1 test pattern @155Mbps

Note7: Minimum average optical power measured at BER less than 1E-10, with a 2<sup>23</sup>-1 PRBS and ER=9dB.

Note8: Measured with a PRBS 2<sup>23</sup>-1 test pattern @155Mbps, over 40km G.652 SMF, BER  $\leq 1 \times 10^{-10}$ .

Note9: Eye Pattern Mask

Note10: LOS Hysteresis

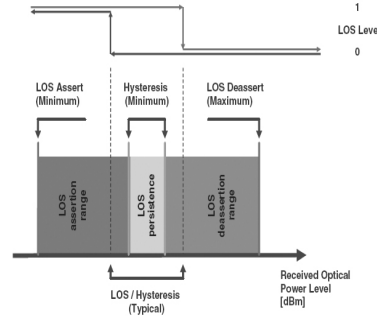
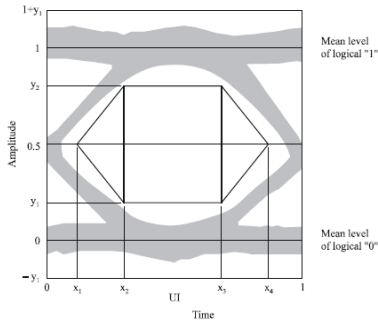

## Functional Description of Transceiver

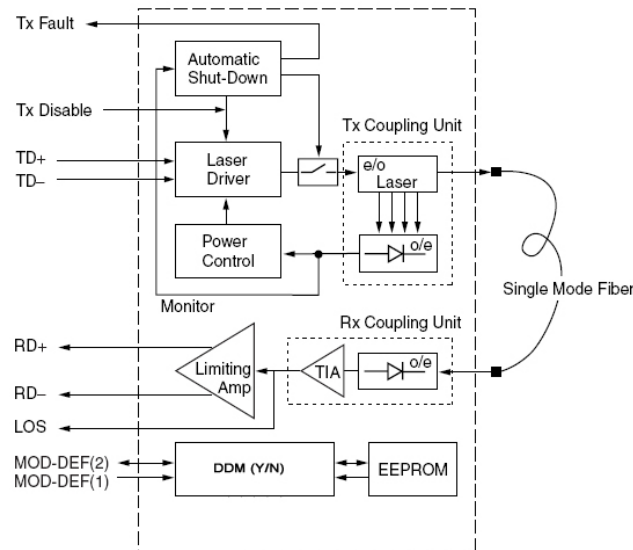

## SFP Transceiver Electrical Pad Layout

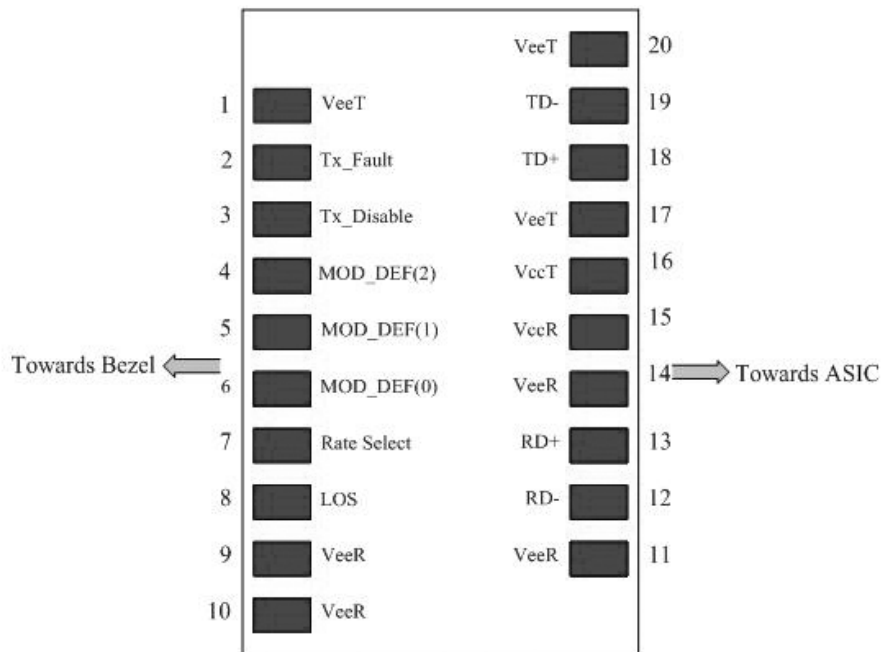
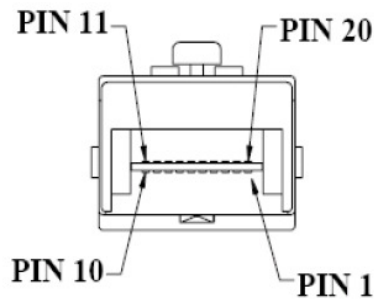

### Pin Function Definitions

Pin Num.	Name	Function Description
1	VeeT	Transmitter Ground
2	TX Fault	Transmitter Fault Indication, open collector/drain output
3	TX Disable	Transmitter Disable
4	MOD-DEF2	Module Definition 2, Data line for Serial ID.
5	MOD-DEF1	Module Definition 1, Clock line for Serial ID.
6	MOD-DEF0	Module Definition 0, Grounded within the module.
7	Rate Select	Not Connect, Function not available
8	LOS	Loss of Signal, open collector/drain output
9	VeeR	Receiver Ground
10	VeeR	Receiver Ground
11	VeeR	Receiver Ground
12	RD-	Inv. Received Data Out

13	RD+	Received Data Out
14	VeeR	Receiver Ground
15	VccR	Receiver Power, 3.3 ± 5%
16	VccT	Transmitter Power, 3.3 ± 5%
17	VeeT	Transmitter Ground
18	TD+	Transmit Data In
19	TD-	Inv. Transmit Data In
20	VeeT	Transmitter Ground

## EEPROM

The serial interface uses the 2-wire serial CMOS EEPROM protocol defined for the ATMEL AT24C02/04 family of components. When the serial protocol is activated, the host generates the serial clock signal (SCL). The positive edge clocks data into those segments of the EEPROM that are not write protected within the SFP transceiver. The negative edge clocks data from the SFP transceiver. The serial data signal (SDA) is bi-directional for serial data transfer. The host uses SDA in conjunction with SCL to mark the start and end of serial protocol activation. The memories are organized as a series of 8-bit data words that can be addressed individually or sequentially.

The Module provides diagnostic information about the present operating conditions. The transceiver generates this diagnostic data by digitization of internal analog signals. Calibration and alarm/warning threshold data is written during device manufacture. Received power monitoring, transmitted power monitoring, bias current monitoring, supply voltage monitoring and temperature monitoring all are implemented. If the module is defined as external calibrated, the diagnostic data are raw A/D values and must be converted to real world units using calibration constants stored in EEPROM locations 56 – 95 at wire serial bus address A2H. The digital diagnostic memory map specific data field define as following .For detail EEPROM information, please refer to the related document of SFF 8472 Rev 9.3.

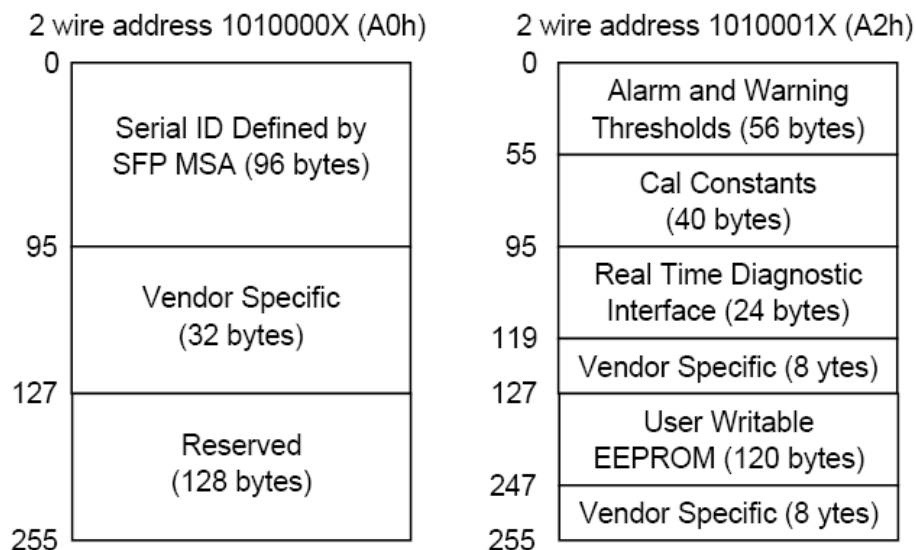

## EEPROM Serial ID Memory Contents

Accessing Serial ID Memory uses the 2 wire address 1010000X(A0H). Memory Contents of Serial ID are shown in Table 1.

**Table 1 Serial ID Memory Contents**

Addr.	Size (Bytes)	Name of Field	Hex	Description
<b>BASE ID FIELDS</b>				
0	1	Identifier	03	SFP
1	1	Ext. Identifier	04	SFP function is defined by serial ID only
2	1	Connector	07	LC Connector
3-10	8	Transceiver	00 10 04 00 00 00 00	OC 3, Single mode, long reach
			00	
11	1	Encoding	03	NRZ
12	1	BR, Nominal	01	155Mbps
13	1	Reserved	00	
14	1	Length (9μm)km	28	Transceiver transmit distance
15	1	Length(9μm)100m	FF	
16	1	Length (50μm) 10m	00	
17	1	Length(62.5μm)10m	00	
18	1	Length (Copper)	00	Not compliant
19	1	Reserved	00	
20-35	16	Vendor name	XX XX XX XX XX XX XX XX XX XX XX XX XX XX XX XX <sup>(note11)</sup>	Vendor name
36	1	Reserved	00	
37-39	3	Vendor OUI	XX XX XX <sup>(note11)</sup>	
40-55	16	Vendor PN	XX XX XX XX XX XX XX XX XX XX XX XX XX XX XX XX <sup>(note11)</sup>	PN
56-59	4	Vendor rev	XX XX XX XX <sup>(note11)</sup>	
60-61	2	Wavelength	XX XX <sup>(note11)</sup>	Wavelength
62	1	Reserved	00	
63	1	CC_BASE	Check Sum (Variable)	Check code for Base ID Fields
<b>EXTENDED ID FIELDS</b>				
64-65	2	Options	00 1A	TX_DISABLE, TX_FAULT and Loss of Signal implemented.
66	1	BR, max	00	
67	1	BR, min	00	

68-83	16	Vendor SN	XX XX XX XX XX XX XX XX 20 20 20 20 20 20 20 20 <sup>(note11)</sup>	Serial Number of transceiver (ASCII). For example "B000822".
84-91	8	Date code	XX XX XX XX XX XX XX XX <sup>(note11)</sup>	Manufactory date code. For example "080405".
92	1	Diagnostic Monitoring Type	XX <sup>(note11)</sup>	Digital diagnostic monitoring implemented
93	1	Enhanced Options	XX <sup>(note11)</sup>	Optional flags
94	1	SFF_8472 Compliance	01	01 for diagnostics (Rev9.3 SFF-8472).
95	1	CC_EXT	Check Sum (Variable)	Check sum for Extended ID Field.
<b>VENDOR SPECIFIC ID FIELDS</b>				
96-127	32	Vendor Specific	Read only	Depends on customer information
128-255	128	Reserved	Read only	

Note10: The "XX" byte should be filled in according to practical case. For more information, please refer to the related document of SFP Multi-Source Agreement (MSA).

## Digital Diagnostic Monitoring Interface (2-Wire Address A2H)

### Alarm and Warning Thresholds (2 Wire Address A2H)

Address	# Bytes	Name of Field	Real Value	Unit
00-01	2	Temp High Alarm	105	Degree C
02-03	2	Temp Low Alarm	-45	Degree C
04-05	2	Temp High Warning	95	Degree C
06-07	2	Temp Low Warning	-42	Degree C
08-09	2	Voltage High Alarm	3.60	V
10-11	2	Voltage Low Alarm	2.90	V
12-13	2	Voltage High Warning	3.50	V
14-15	2	Voltage Low Warning	3.00	V
16-17	2	Bias High Alarm	90	mA
18-19	2	Bias Low Alarm	2	mA
20-21	2	Bias High Warning	80	mA
22-23	2	Bias Low Warning	3	mA
24-25	2	TX Power High Alarm	6	dBm
26-27	2	TX Power Low Alarm	1	dBm
28-29	2	TX Power High Warning	5	dBm
30-31	2	TX Power Low Warning	2	dBm
32-33	2	RX Power High Alarm	-9	dBm
34-35	2	RX Power Low Alarm	-36	dBm
36-37	2	RX Power High Warning	-10	dBm
38-39	2	RX Power Low Warning	-35	dBm

40-55	16	Reserved		
-------	----	----------	--	--

### Calibration Constants (2 Wire Address A2H)

Address	# Bytes	Name of Field	HEX	Description
56-59	4	RX_PWR (4)	00 00 00 00	Set to zero for “internally calibrated” devices.
60-63	4	RX_PWR (3)	00 00 00 00	Set to zero for “internally calibrated” devices.
64-67	4	RX_PWR (2)	00 00 00 00	Set to zero for “internally calibrated” devices.
68-71	4	RX_PWR (1)	3F 80 00 00	Set to 1 for “internally calibrated” devices.
72-75	4	RX_PWR (0)	00 00 00 00	Set to zero for “internally calibrated” devices.
76-77	2	TX_I (Slope)	01 00	Set to 1 for “internally calibrated” devices.
78-79	2	TX_I (Offset)	00 00	Set to zero for “internally calibrated” devices.
80-81	2	TX_PWR (Slope)	01 00	Set to 1 for “internally calibrated” devices.
82-83	2	TX_PWR (Offset)	00 00	Set to zero for “internally calibrated” devices.
84-85	2	T (Slope)	01 00	Set to 1 for “internally calibrated” devices.
86-87	2	T (Offset)	00 00	Set to zero for “internally calibrated” devices.
88-89	2	V (Slope)	01 00	Set to 1 for “internally calibrated” devices.
90-91	2	V (Offset)	00 00	Set to zero for “internally calibrated” devices.
92-94	3	Reserved	00 00 00	Reserved
95	1	Checksum	XX	Checksum of bytes 0 – 94.

### A/D Value (2 Wire Address A2H)

Address	# Bytes	Name of Field	Description
96-97	2	Temperature (MSB, LSB)	Internally measured module temperature
98-99	2	Supply Voltage (MSB, LSB)	Internally measured supply voltage in module
100-101	2	TX Bias Current (MSB, LSB)	Internally measured TX Bias current
102-103	2	TX Optical Power (MSB, LSB)	Internally measured TX Optical Power
104-105	2	RX Received Power (MSB, LSB)	Measured Rx input power
106-109	4	Reserved	

\*Temperature (Signed twos complement value)

A2H Byte 96 (Temperature MSB)								A2H Byte 97 (Temperature LSB)							
S	2 <sup>6</sup>	2 <sup>5</sup>	2 <sup>4</sup>	2 <sup>3</sup>	2 <sup>2</sup>	2 <sup>1</sup>	2 <sup>0</sup>	2 <sup>1</sup>	2 <sup>2</sup>	2 <sup>3</sup>	2 <sup>4</sup>	2 <sup>5</sup>	2 <sup>6</sup>	2 <sup>7</sup>	2 <sup>8</sup>

Supply Voltage, TX Bias Current, TX Optical Power, RX Received Power (Unsigned values)

A2H Byte 98 (Vcc MSB)								A2H Byte 99 (Vcc LSB)							
A2H Byte 100 (TX Bias MSB)								A2H Byte 101 (TX Bias LSB)							
A2H Byte 102 (TX Power MSB)								A2H Byte 103 (TX Power LSB)							
A2H Byte 104 (RX Power MSB)								A2H Byte 105 (RX Power LSB)							
2 <sup>15</sup>	2 <sup>14</sup>	2 <sup>13</sup>	2 <sup>12</sup>	2 <sup>11</sup>	2 <sup>10</sup>	2 <sup>9</sup>	2 <sup>8</sup>	2 <sup>7</sup>	2 <sup>6</sup>	2 <sup>5</sup>	2 <sup>4</sup>	2 <sup>3</sup>	2 <sup>2</sup>	2 <sup>1</sup>	2 <sup>0</sup>

The digital value conversions are updated every 13ms (nominal) or 20ms (max) in rotation. After getting digital value, each measurement could be obtained by multiplying digital value by corresponding LSB value:

Temperature = Temp (Digital Value) × LSB<sub>Temp</sub> = Temp (Digital Value) × 1/256; when Temperature < 128

Temperature = Temp (Digital Value) × LSB<sub>Temp</sub> = [Temp (Digital Value) × 1/256] - 256; when Temperature ≥ 128

V<sub>cc</sub> = V<sub>cc</sub>(Digital Value) × LSB<sub>Vcc</sub> = V<sub>cc</sub>(Digital Value) × 100μV

TX Bias Current = TX Bias Current (Digital Value) × LSB<sub>TX,Bias</sub> = TX Bias Current (Digital Value) × 2μA

TX Power = TX Power (Digital Value) × LSB<sub>TXPower</sub> = TX Power (Digital Value) × 0.1μW

RX Power = RX Power (Digital Value) × LSB<sub>RXPower</sub> = RX Power (Digital Value) × 0.1μW

### Status Bits and Alarm/Warning Flag Bits (2 Wire Address A2H)

Address	Bit	Name	Description
110	7	TX Disable State	Digital state of TX disable (1) and enabled (0)
110	6	Soft TX Disable	Not implemented
110	5-3	Reserved	
110	2	TX Fault State	1=TX failure state, 0=TX normal state
110	1	LOS	Digital state of LOS output pin. 0=optical signal detected, 1=no optical signal detected
110	0	Data_Ready_Bar	Not implemented.
111	7-0	Reserved	Reserved
112	7	Temp High Alarm	Set when internal temperature exceeds high alarm level.
112	6	Temp Low Alarm	Set when internal temperature is below low alarm level.
112	5	Vcc-High Alarm	Set when internal supply voltage exceeds high alarm level.
112	4	Vcc Low Alarm	Set when internal supply voltage is below low alarm level.
112	3	TX Bias High Alarm	Set when TX Bias current exceeds high alarm level.
112	2	TX Bias Low Alarm	Set when TX Bias current is below low alarm level.
112	1	TX Power High Alarm	Set when TX Power exceeds high alarm level.
112	0	TX Power Low Alarm	Set when TX Power is below low alarm level.
113	7	RX Power High Alarm	Set when Received Power exceeds high alarm level.
113	6	RX Power Low Alarm	Set when Received Power is below low alarm level.
113	5-0	Reserved Alarm	
114-115	All	Reserved	
116	7	Temp High Warning	Set when internal temperature exceeds high warning level.



## Mechanical Specifications

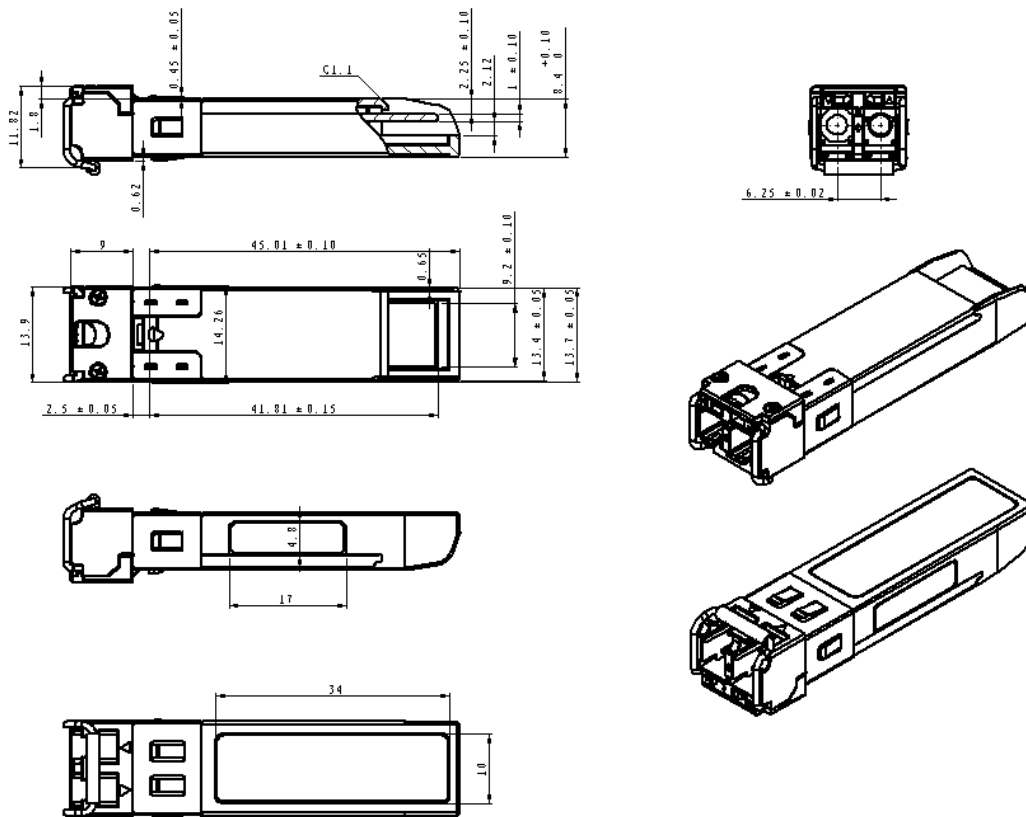

## Obtaining Document

You can visit our website:

<http://www.eoptolink.com>

Or contact Eoptolink Technology Inc., Ltd. listed at the end of the documentation to get the latest documents.

## Revision History

Revision	Initiated	Reviewed	Approved	DCN	Release Date
V2.a	Tim.Liang	Kelly.Cao		Released.	Oct 24, 2009
V2.b	Kelly			Revise the A2H.	Nov 24, 2009
V2.c	Kelly			Complete the CWDM wavelength.	Jan 18, 2010

### Notice:

Eoptolink reserves the right to make changes to or discontinue any optical link product or service identified in this publication, without notice, in order to improve design and/or performance. Applications that are described herein for any of the optical link products are for illustrative purposes only. Eoptolink makes no representation or warranty that such applications will be suitable for the specified use without further testing or modification.

### Contact:

Add: Floor 5, Building 2, No. 21 Gaopeng Avenue, High-Tech District, CHENGDU, SICHUAN  
610041 P.R. CHINA

Tel: (+86) 028-85122709 ext 816 & 809

Fax: (+86) 028-85121912

Postal: 610041

E-mail: [sales@eoptolink.com](mailto:sales@eoptolink.com)

<http://www.eoptolink.com>