

EOLS-1612-40-X Series

Single-Mode CWDM SFP 1.25Gbps FC/GBE
 Duplex SFP Transceiver
 RoHS6 Compliant

Features

- ◆ Operating Data Rate up to 1.25Gbps
- ◆ 18-Wavelength CWDM DFB LD Transmitter
 from 1270nm to 1610nm, with Step 20nm
- ◆ 17dB Power Budget at Least
- ◆ 40km with 9/125 μm SMF
- ◆ Single 3.3V Power Supply and TTL Control Logic
 Interface
- ◆ Hot-Pluggable SFP Footprint Duplex LC
 Connector Interface
- ◆ Class 1 FDA and IEC60825-1 Laser Safety
 Compliant
- ◆ Operating Case Temperature
 Standard: 0°C~+70°C
 Extended: -20°C~+70°C
- ◆ Compliant with SFP MSA Specification
- ◆ Compliant with SFF-8472 Digital Diagnostic
 Monitor Interface



Applications

- ◆ Gigabit Ethernet Switches and Routers
- ◆ Fiber Channel Switch Infrastructure
- ◆ Other Optical Links

Ordering Information

| Part No. | Data Rate | Fiber | Distance ^{*(note2)} | Interface | Temperature | DDMI |
|------------------------------------|-----------|-------|------------------------------|-----------|-------------|------|
| EOLS-1612-40-X ^{*(note1)} | 1.25Gbps | SMF | 40km | LC | Standard | NO |
| EOLS-1612-40-XI | 1.25Gbps | SMF | 40km | LC | Extended | NO |
| EOLS-1612-40-XD | 1.25Gbps | SMF | 40km | LC | Standard | YES |
| EOLS-1612-40-XDI | 1.25Gbps | SMF | 40km | LC | Extended | YES |

Note1: Standard version, X refer to CWDM Wavelength range 1270nm to 1610nm, A=27, B=29...Q=59, R=61;

Note2: 40km with 9/125 μm SMF

CWDM* Wavelength(0~70 °C)

| Band | Nomenclature | Wavelength(nm) | | |
|-------------------------|--------------|----------------|------|--------|
| | | Min. | Typ. | Max. |
| O-band Original | A | 1264 | 1270 | 1277.5 |
| | B | 1284 | 1290 | 1297.5 |
| | C | 1304 | 1310 | 1317.5 |
| | D | 1324 | 1330 | 1337.5 |
| | E | 1344 | 1350 | 1357.5 |
| E-band Extended | F | 1364 | 1370 | 1377.5 |
| | G | 1384 | 1390 | 1397.5 |
| | H | 1404 | 1410 | 1417.5 |
| | I | 1424 | 1430 | 1437.5 |
| | J | 1444 | 1450 | 1457.5 |
| S-band Short Wavelength | K | 1464 | 1470 | 1477.5 |
| | L | 1484 | 1490 | 1497.5 |
| | M | 1504 | 1510 | 1517.5 |
| | N | 1524 | 1530 | 1537.5 |
| C-band Conventional | O | 1544 | 1550 | 1557.5 |
| L-band Long Wavelength | P | 1564 | 1570 | 1577.5 |
| | Q | 1584 | 1590 | 1597.5 |
| | R | 1604 | 1610 | 1617.5 |

CWDM*: 18 Wavelengths from 1270 nm to 1610 nm, with 20 nm span.

Regulatory Compliance

| Feature | Standard | Performance |
|--|--|--|
| Electrostatic Discharge (ESD) to the Electrical Pins | MIL-STD-883G Method 3015.7 | Class 1C (>1000V) |
| Electrostatic Discharge to the Enclosure | EN 55024:1998+A1+A2 IEC-61000-4-2 GR-1089-CORE | Compliant with standards |
| Electromagnetic Interference (EMI) | FCC Part 15 Class B EN55022:2006 CISPR 22B :2006 | Compliant with standards Noise frequency range: 30MHz to 6GHz. Good system EMI design |

| | | |
|-----------------------|--|---|
| | VCCI Class B | practice required to achieve Class B margins. System margins are dependent on customer host board and chassis design. |
| Immunity | EN 55024:1998+A1+A2 IEC 61000-4-3 | Compliant with standards. 1KHz sine-wave, 80% AM, from 80MHz to 1GHz. No effect on transmitter/receiver performance is detectable between these limits. |
| Laser Eye Safety | FDA 21CFR 1040.10 and 1040.11 EN (IEC) 60825-1:2007 EN (IEC) 60825-2:2004+A1 | CDRH compliant and Class I laser product. TüV Certificate No. 50135086 |
| Component Recognition | UL and CUL EN60950-1:2006 | UL file E317337 TüV Certificate No. 50135086 (CB scheme) |
| RoHS6 | 2002/95/EC 4.1&4.2 2005/747/EC 5&7&13 | Compliant with standards ^{*note3} |

Note3: For update of the equipments and strict control of raw materials, EOPTOLINK has the ability to supply the customized products since Jan 1st, 2007, which meet the requirements of RoHS6 (Restrictions on use of certain Hazardous Substances) of European Union.

In light of item 5 in RoHS exemption list of RoHS Directive 2002/95/EC, Item 5: Lead in glass of cathode ray tubes, electronic components and fluorescent tubes.

In light of item 13 in RoHS exemption list of RoHS Directive 2005/747/EC, Item 13: Lead and cadmium in optical and filter glass. The three exemptions are being concerned for Eoptolink's transceivers, because Eoptolink's transceivers use glass, which may contain Pb, for components such as lenses, windows, isolators, and other electronic components.

Product Description

The EOLS-1612-40-X series single mode transceiver is small form factor pluggable module for duplex optical data communications such as Gigabit Ethernet 1000BASE-ZX and Fiber Channel 1x SM-LC-L FC-PI. It is with the SFP 20-pin connector to allow hot plug capability.

This module is designed for single mode fiber and operates at a nominal wavelength of CWDM wavelength. There are eighteen center wavelengths available from 1270nm to 1610nm, with each step 20nm. A guaranteed minimum optical link budget of 17dB is offered.

The transmitter section uses a multiple quantum well CWDM DFB laser and is a class 1 laser compliant according to International Safety Standard IEC-60825. The receiver section uses an integrated InGaAs detector preamplifier (IDP) mounted in an optical header and a limiting post-amplifier IC.

The EOLS-1612-40-XD series are designed to be compliant with SFF-8472.

Absolute Maximum Ratings

| Parameter | Symbol | Min. | Max. | Unit |
|-----------------------------|--------|------|------|------|
| Storage Temperature | Ts | -40 | +85 | °C |
| Supply Voltage | Vcc | -0.5 | 3.6 | V |
| Operating Relative Humidity | | - | 95 | % |

*Exceeding any one of these values may destroy the device immediately.

Recommended Operating Conditions

| Parameter | Symbol | Min. | Typical | Max. | Unit | |
|----------------------------|----------------|-----------------|---------|------|------|----|
| Operating Case Temperature | T _A | EOLS-1612-40-X | 0 | | +70 | °C |
| | | EOLS-1612-40-XI | -20 | | +70 | |
| Power Supply Voltage | Vcc | 3.15 | 3.3 | 3.45 | V | |
| Power Supply Current | Icc | | | 300 | mA | |
| Data Rate | GBE | | 1.25 | | Gbps | |
| | FC | | 1.063 | | | |

Performance Specifications - Electrical

| Parameter | Symbol | Min. | Typ. | Max | Unit | Notes |
|---------------------------------|------------------|------|------|---------|------|---------------------------------|
| Transmitter | | | | | | |
| LVPECL Inputs(Differential) | V _{in} | 400 | | 2000 | mVpp | AC coupled inputs*(note5) |
| Input Impedance (Differential) | Z _{in} | 85 | 100 | 115 | ohm | R _{in} > 100 kohm @ DC |
| TX_Dis | Disable | 2 | | Vcc+0.3 | V | |
| | Enable | 0 | | 0.8 | | |
| TX_FAULT | Fault | 2 | | Vcc+0.3 | V | |
| | Normal | 0 | | 0.8 | | |
| Receiver | | | | | | |
| LVPECL Outputs (Differential) | V _{out} | 400 | | 2000 | mVpp | AC coupled outputs*(note5) |
| Output Impedance (Differential) | Z _{out} | 85 | 100 | 115 | ohm | |
| RX_LOS | LOS | 2 | | Vcc+0.3 | V | |
| | Normal | 0 | | 0.8 | V | |
| MOD_DEF (0:2) | VoH | 2.5 | | | V | With Serial ID |
| | VoL | 0 | | 0.5 | V | |

Optical and Electrical Characteristics

(CWDM DFB and PIN, 40km)

| Parameter | Symbol | Min. | Typical | Max. | Unit |
|-----------|--------|------|---------|------|------|
|-----------|--------|------|---------|------|------|

| | | | | | |
|--|---|---------------|-------------|-----------------|------|
| 9μm Core Diameter SMF | L | | 40 | | km |
| Data Rate | | | 1.063/1.25 | | Gbps |
| Transmitter | | | | | |
| Center Wavelength | λ_c | λ_c-6 | λ_c | $\lambda_c+7.5$ | nm |
| Spectral Width (-20dB) | $\Delta\lambda$ | | | 1 | nm |
| Average Output Power ^{*(note3)} | P _{out} | -5 | | 0 | dBm |
| Side Mode Suppression Ratio | SMSR | 30 | | | dB |
| Extinction Ratio ^{*(note4)} | ER | 8.2 | | | dB |
| Rise/Fall Time(20%~80%) | tr/tf | | | 0.26 | ns |
| Total Jitter | TJ | | | 56.5 | ps |
| Output Optical Eye ^{*(note4)} | Compatible with IEEE 802.3ah-2004 ^{*(note8)} | | | | |
| TX_Disable Assert Time | t _{off} | | | 10 | μs |
| P _{out} @TX Disable Asserted | P _{out} | | | -45 | dBm |
| Receiver | | | | | |
| Center Wavelength | λ_c | 1260 | | 1600 | nm |
| Receiver Sensitivity ^{*(note6)} | P _{min} | | -26 | -22 | dBm |
| Receiver Overload | P _{max} | -3 | | 0 | dBm |
| Return Loss | | 12 | | | dB |
| Optical Path Penalty ^{*(note7)} | | | | 1 | dB |
| LOS De-Assert | LOSD | | | -23 | dBm |
| LOS Assert | LOSA | -42 | | | dBm |
| LOS Hysteresis ^{*(note9)} | | 0.5 | | | dB |

Note3: Output is coupled into a 9/125μm single-mode fiber.

Note4: Filtered, measured with a PRBS 2⁷-1 test pattern @1.25Gbps

Note5: LVPECL logic, internally AC coupled.

Note6: Minimum average optical power measured at BER less than 1E-12, with a 2⁷-1 PRBS and ER=9dB.

Note7: Measured with a PRBS 2⁷-1 test pattern @1.25Gbps, over 40km G.652 SMF, BER ≤1×10⁻¹².

Note8: Eye Pattern Mask

Note9: LOS Hysteresis

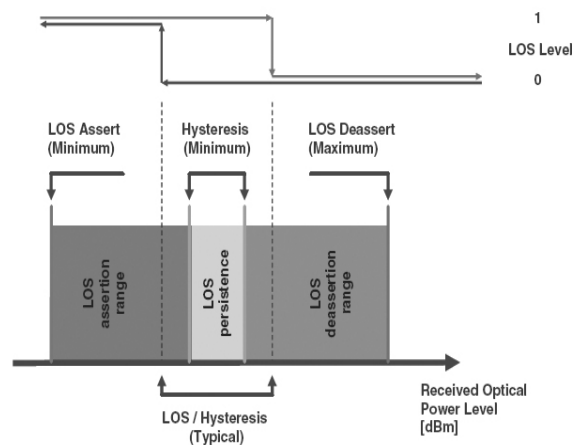
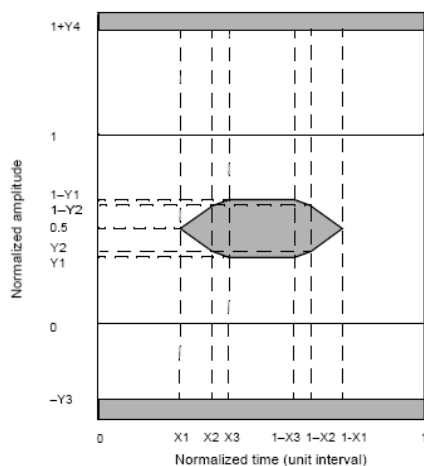

Functional Description of Transceiver

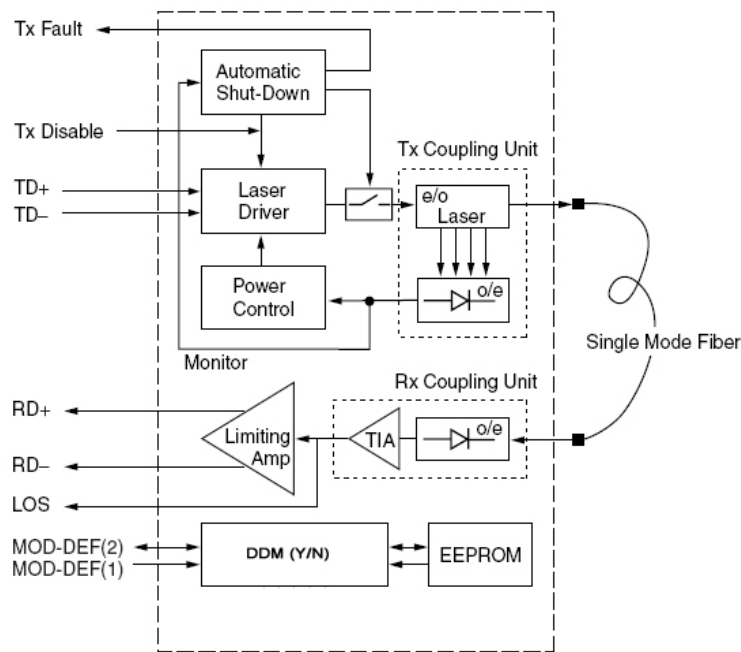

SFP Transceiver Electrical Pad Layout

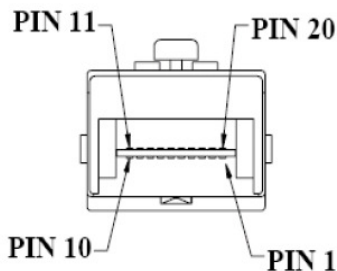
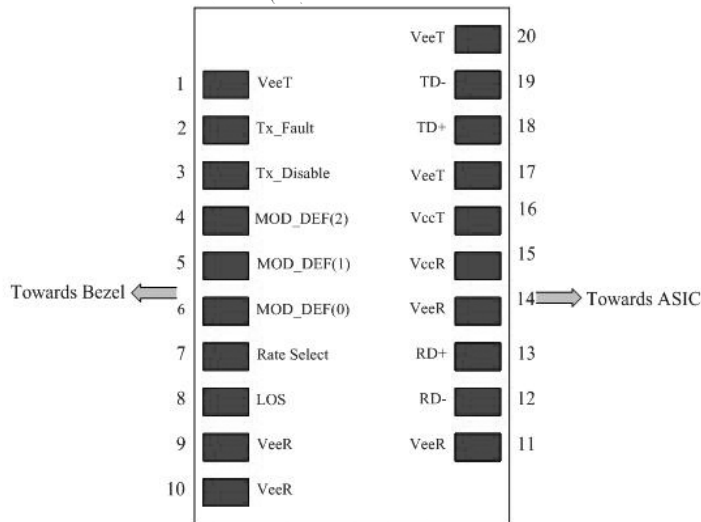

Pin Function Definitions

| Pin Num. | Name | Function | Plug Seq. | Notes |
|----------|-------------|------------------------------|-----------|------------------------------------|
| 1 | VeeT | Transmitter Ground | 1 | 5) |
| 2 | TX Fault | Transmitter Fault Indication | 3 | 1) |
| 3 | TX Disable | Transmitter Disable | 3 | 2) Module disables on high or open |
| 4 | MOD-DEF2 | Module Definition 2 | 3 | 3) Data line for Serial ID. |
| 5 | MOD-DEF1 | Module Definition 1 | 3 | 3) Clock line for Serial ID. |
| 6 | MOD-DEF0 | Module Definition 0 | 3 | 3) Grounded within the module. |
| 7 | Rate Select | Not Connect | 3 | Function not available |
| 8 | LOS | Loss of Signal | 3 | 4) |
| 9 | VeeR | Receiver Ground | 1 | 5) |
| 10 | VeeR | Receiver Ground | 1 | 5) |
| 11 | VeeR | Receiver Ground | 1 | 5) |
| 12 | RD- | Inv. Received Data Out | 3 | 6) |
| 13 | RD+ | Received Data Out | 3 | 6) |
| 14 | VeeR | Receiver Ground | 1 | 5) |
| 15 | VccR | Receiver Power | 2 | 7) $3.3 \pm 5\%$ |
| 16 | VccT | Transmitter Power | 2 | 7) $3.3 \pm 5\%$ |
| 17 | VeeT | Transmitter Ground | 1 | 5) |
| 18 | TD+ | Transmit Data In | 3 | 8) |
| 19 | TD- | Inv. Transmit Data In | 3 | 8) |
| 20 | VeeT | Transmitter Ground | 1 | 5) |

Notes:

1) TX Fault is an open collector/drain output, which should be pulled up with a 4.7K – 10K Ω resistor on the host board. Pull up voltage between 2.0V and VccT, R+0.3V. When high, output indicates a laser fault of some kind. Low indicates normal operation. In the low state, the output will be pulled to < 0.8V.

2) TX disable is an input that is used to shut down the transmitter optical output. It is pulled up within the module with a 4.7 – 10 K Ω resistor. Its states are:

Low (0 – 0.8V): Transmitter on

(>0.8, < 2.0V): Undefined

High (2.0 – 3.465V): Transmitter Disabled

Open: Transmitter Disabled

3) Modulation Absent, connected to VEET or VEER in the module.

4) LOS (Loss of Signal) is an open collector/drain output, which should be pulled up with a 4.7K –

10K Ω resistor. Pull up voltage between 2.0V and VccT, R+0.3V. When high, this output indicates the received optical power is below the worst-case receiver sensitivity (as defined by the standard in use). Low indicates normal operation. In the low state, the output will be pulled to < 0.8V.

5) VeeR and VeeT may be internally connected within the SFP module.

6) RD-/+ : These are the differential receiver outputs. They are AC coupled 100 Ω differential lines which should be terminated with 100 Ω (differential) at the user SERDES. The AC coupling is done inside the module and is thus not required on the host board. The voltage swing on these lines will be between 400 and 2000mV differential (200 –1000mV single ended) when properly terminated.

7) VccR and VccT are the receiver and transmitter power supplies. They are defined as 3.3V \pm 5% at the SFP connector pin. Maximum supply current is 300mA. Recommended host board power supply filtering is shown below. Inductors with DC resistance of less than 1 ohm should be used in order to maintain the required voltage at the SFP input pin with 3.3V supply voltage. When the recommended supply-filtering network is used, hot plugging of the SFP transceiver module will result in an inrush current of no more than 30mA greater than the steady state value. VccR and VccT may be internally connected within the SFP transceiver module.

8) TD-/+ : These are the differential transmitter inputs. They are AC-coupled, differential lines with 100 Ω differential termination inside the module. The AC coupling is done inside the module and is thus not required on the host board. The inputs will accept differential swings of 400 – 2000mV (200 – 1000mV single-ended).

EEPROM

The serial interface uses the 2-wire serial CMOS EEPROM protocol defined for the ATMEL AT24C02/04 family of components. When the serial protocol is activated, the host generates the serial clock signal (SCL). The positive edge clocks data into those segments of the EEPROM that are not write protected within the SFP transceiver. The negative edge clocks data from the SFP transceiver. The serial data signal (SDA) is bi-directional for serial data transfer. The host uses SDA in conjunction with SCL to mark the start and end of serial protocol activation. The memories are organized as a series of 8-bit data words that can be addressed individually or sequentially.

The Module provides diagnostic information about the present operating conditions. The transceiver generates this diagnostic data by digitization of internal analog signals. Calibration and alarm/warning threshold data is written during device manufacture. Received power monitoring, transmitted power monitoring, bias current monitoring, supply voltage monitoring and temperature monitoring all are implemented. If the module is defined as external calibrated, the diagnostic data are raw A/D values and must be converted to real world units using calibration constants stored in EEPROM locations 56 – 95 at wire serial bus address A2H. The digital diagnostic memory map specific data field define as following .For detail EEPROM information, please refer to the related document of SFF 8472 Rev 9.3.

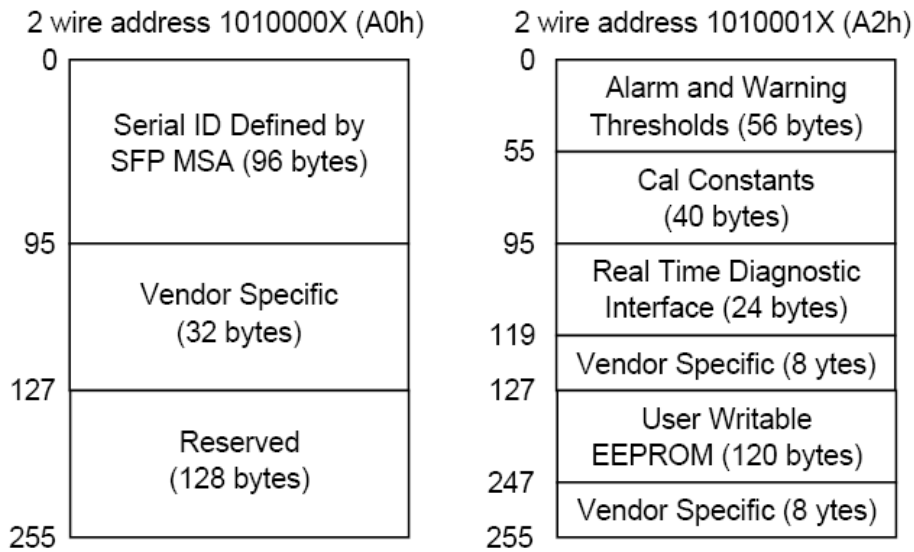

EEPROM Serial ID Memory Contents

Accessing Serial ID Memory uses the 2 wire address 1010000X(A0H). Memory Contents of Serial ID are shown in Table 1. The following information is according to EOLS-1612-40-ND.

Table 1 Serial ID Memory Contents

| Addr. | Size (Bytes) | Name of Field | Hex | Description |
|-----------------------|--------------|-------------------|--|---|
| BASE ID FIELDS | | | | |
| 0 | 1 | Identifier | 03 | SFP |
| 1 | 1 | Ext. Identifier | 04 | SFP function is defined by serial ID only |
| 2 | 1 | Connector | 07 | LC Connector |
| 3-10 | 8 | Transceiver | 00 00 00 02 12 00 0D 01 | Transmitter Code |
| 11 | 1 | Encoding | 01 | 8B10B |
| 12 | 1 | BR, Nominal | 0D | 1.25Gbps |
| 13 | 1 | Reserved | 00 | |
| 14 | 1 | Length (9μm)km | 28 | Transceiver transmit distance |
| 15 | 1 | Length(9μm)100m | FF | |
| 16 | 1 | Length (50μm) 10m | 00 | |
| 17 | 1 | Length(62.5μm)10m | 00 | |
| 18 | 1 | Length (Copper) | 00 | Not compliant |
| 19 | 1 | Reserved | 00 | |
| 20-35 | 16 | Vendor name | 45 4F 50 54 4F 4C 49 4E 4B 20 20 20 20 20 20 20 20 | EOPTOLINK (ASCII) |

| | | | | |
|----------------------------------|-----|-------------------------------|---|--|
| 36 | 1 | Reserved | 00 | |
| 37-39 | 3 | Vendor OUI | 00 00 00 | |
| 40-55 | 16 | Vendor PN | 45 4F 4C 53 2D 31 36 31 32 2D 34 30 2D 4E 44 20 20 20 | EOLS-1612-40-ND |
| 56-59 | 4 | Vendor rev | 31 2E 30 20 | 1.0 |
| 60-61 | 2 | Wavelength | 05 FA | CWDM, 1530nm |
| 62 | 1 | Reserved | 00 | |
| 63 | 1 | CC_BASE | Check Sum (Variable) | Check code for Base ID Fields |
| EXTENDED ID FIELDS | | | | |
| 64-65 | 2 | Options | 00 1A | TX_DISABLE, TX_FAULT and Loss of Signal implemented. |
| 66 | 1 | BR, max | 00 | |
| 67 | 1 | BR, min | 00 | |
| 68-83 | 16 | Vendor SN | XX XX XX XXXX XX XX XX 20 20 20 20 20 20 20 20 ^(note9) | Serial Number of transceiver (ASCII). For example "B000822". |
| 84-91 | 8 | Date code | XX XX XX XX XX XX XX XX ^(note9) | Manufactory date code. For example "080405". |
| 92 | 1 | Diagnostic Monitoring Type | XX ^(note9) | Digital diagnostic monitoring implemented |
| 93 | 1 | Enhanced Options | XX ^(note9) | Optional flags |
| 94 | 1 | SFF_8472 Compliance | XX ^(note9) | 01 for Rev9.3 SFF-8472. |
| 95 | 1 | CC_EXT | Check Sum (Variable) | Check sum for Extended ID Field. |
| VENDOR SPECIFIC ID FIELDS | | | | |
| 96-127 | 32 | Vendor Specific | Read only | Depends on customer information |
| 128-255 | 128 | Reserved | Read only | |

Note9: The "xx" byte should be filled in according to practical case. For more information, please refer to the related document of SFP Multi-Source Agreement (MSA).

Digital Diagnostic Monitoring Interface (2-Wire Address A2H)

Alarm and Warning Thresholds (2 Wire Address A2H)

| Address | # Bytes | Name of Field | HEX | Real Value | Unit |
|---------|---------|-------------------|-------|------------|----------|
| 00-01 | 2 | Temp High Alarm | 6E 00 | 110 | Degree C |
| 02-03 | 2 | Temp Low Alarm | F6 00 | -10 | Degree C |
| 04-05 | 2 | Temp High Warning | 55 00 | 85 | Degree C |
| 06-07 | 2 | Temp Low Warning | EC 00 | -20 | Degree C |

| | | | | | |
|-------|----|-----------------------|-------|-----|-----|
| 08-09 | 2 | Voltage High Alarm | 8C A0 | 3.6 | V |
| 10-11 | 2 | Voltage Low Alarm | 71 48 | 2.9 | V |
| 12-13 | 2 | Voltage High Warning | 88 B8 | 3.5 | V |
| 14-15 | 2 | Voltage Low Warning | 75 30 | 3.0 | V |
| 16-17 | 2 | Bias High Alarm | AF C8 | 90 | mA |
| 18-19 | 2 | Bias Low Alarm | 03 E8 | 2 | mA |
| 20-21 | 2 | Bias High Warning | 9C 40 | 80 | mA |
| 22-23 | 2 | Bias Low Warning | 05 DC | 3 | mA |
| 24-25 | 2 | TX Power High Alarm | 31 2D | 1 | dBm |
| 26-27 | 2 | TX Power Low Alarm | 09 D0 | -6 | dBm |
| 28-29 | 2 | TX Power High Warning | 27 10 | 0 | dBm |
| 30-31 | 2 | TX Power Low Warning | 0C 5A | -5 | dBm |
| 32-33 | 2 | RX Power High Alarm | 13 94 | -3 | dBm |
| 34-35 | 2 | RX Power Low Alarm | 00 32 | -23 | dBm |
| 36-37 | 2 | RX Power High Warning | 0F 8D | -4 | dBm |
| 38-39 | 2 | RX Power Low Warning | 00 3F | -22 | dBm |
| 40-55 | 16 | Reserved | | | |

Calibration Constants (2 Wire Address A2H)

| Address | # Bytes | Name of Field | HEX | Description |
|---------|---------|-----------------|-------------|--|
| 56-59 | 4 | RX_PWR (4) | 00 00 00 00 | Set to zero for “internally calibrated” devices. |
| 60-63 | 4 | RX_PWR (3) | 00 00 00 00 | Set to zero for “internally calibrated” devices. |
| 64-67 | 4 | RX_PWR (2) | 00 00 00 00 | Set to zero for “internally calibrated” devices. |
| 68-71 | 4 | RX_PWR (1) | 3F 80 00 00 | Set to 1 for “internally calibrated” devices. |
| 72-75 | 4 | RX_PWR (0) | 00 00 00 00 | Set to zero for “internally calibrated” devices. |
| 76-77 | 2 | TX_I (Slope) | 01 00 | Set to 1 for “internally calibrated” devices. |
| 78-79 | 2 | TX_I (Offset) | 00 00 | Set to zero for “internally calibrated” devices. |
| 80-81 | 2 | TX_PWR (Slope) | 01 00 | Set to 1 for “internally calibrated” devices. |
| 82-83 | 2 | TX_PWR (Offset) | 00 00 | Set to zero for “internally calibrated” devices. |
| 84-85 | 2 | T (Slope) | 01 00 | Set to 1 for “internally calibrated” devices. |
| 86-87 | 2 | T (Offset) | 00 00 | Set to zero for “internally calibrated” devices. |
| 88-89 | 2 | V (Slope) | 01 00 | Set to 1 for “internally calibrated” devices. |
| 90-91 | 2 | V (Offset) | 00 00 | Set to zero for “internally calibrated” devices. |

| | | | | |
|-------|---|----------|----------|---------------------------|
| 92-94 | 3 | Reserved | 00 00 00 | Reserved |
| 95 | 1 | Checksum | XX | Checksum of bytes 0 – 94. |

A/D Value (2 Wire Address A2H)

| Address | # Bytes | Name of Field | Description |
|---------|---------|------------------------------|--|
| 96-97 | 2 | Temperature (MSB, LSB) | Internally measured module temperature |
| 98-99 | 2 | Supply Voltage (MSB, LSB) | Internally measured supply voltage in module |
| 100-101 | 2 | TX Bias Current (MSB, LSB) | Internally measured TX Bias current |
| 102-103 | 2 | TX Optical Power (MSB, LSB) | Internally measured TX Optical Power |
| 104-105 | 2 | RX Received Power (MSB, LSB) | Measured Rx input power |
| 106-109 | 4 | Reserved | |

*Temperature (Signed twos complement value)

| A2H Byte 96 (Temperature MSB) | | | | | | | | A2H Byte 97 (Temperature LSB) | | | | | | | |
|-------------------------------|----------------|----------------|----------------|----------------|----------------|----------------|----------------|-------------------------------|-----------------|-----------------|-----------------|-----------------|-----------------|-----------------|-----------------|
| S | 2 ⁶ | 2 ⁵ | 2 ⁴ | 2 ³ | 2 ² | 2 ¹ | 2 ⁰ | 2 ⁻¹ | 2 ⁻² | 2 ⁻³ | 2 ⁻⁴ | 2 ⁻⁵ | 2 ⁻⁶ | 2 ⁻⁷ | 2 ⁻⁸ |

Supply Voltage, TX Bias Current, TX Optical Power, RX Received Power (Unsigned Values)

| A2H Byte 98 (Vcc MSB) | | | | | | | | A2H Byte 99 (Vcc LSB) | | | | | | | |
|-----------------------------|-----------------|-----------------|-----------------|-----------------|-----------------|----------------|----------------|-----------------------------|----------------|----------------|----------------|----------------|----------------|----------------|----------------|
| A2H Byte 100 (TX Bias MSB) | | | | | | | | A2H Byte 101 (TX Bias LSB) | | | | | | | |
| A2H Byte 102 (TX Power MSB) | | | | | | | | A2H Byte 103 (TX Power LSB) | | | | | | | |
| A2H Byte 104 (RX Power MSB) | | | | | | | | A2H Byte 105 (RX Power LSB) | | | | | | | |
| 2 ¹⁵ | 2 ¹⁴ | 2 ¹³ | 2 ¹² | 2 ¹¹ | 2 ¹⁰ | 2 ⁹ | 2 ⁸ | 2 ⁷ | 2 ⁶ | 2 ⁵ | 2 ⁴ | 2 ³ | 2 ² | 2 ¹ | 2 ⁰ |

The digital value conversions are updated every 13ms (nominal) or 20ms (max) in rotation. After getting digital value, each measurement could be obtained by multiplying digital value by corresponding LSB value:

Temperature = Temp (Digital Value) × LSB_{Temp} = Temp (Digital Value) × 1/256; when Temperature < 128

Temperature = Temp (Digital Value) × LSB_{Temp} = [Temp (Digital Value) × 1/256] - 256; when Temperature ≥ 128

V_{cc} = V_{cc}(Digital Value) × LSB_{Vcc} = V_{cc}(Digital Value) × 100μV

TX Bias Current = TX Bias Current (Digital Value) × LSB_{TX,Bias} = TX Bias Current (Digital Value) × 2μA

TX Power = TX Power (Digital Value) × LSB_{TXPower} = TX Power (Digital Value) × 0.1μW

RX Power = RX Power (Digital Value) × LSB_{RXPower} = RX Power (Digital Value) × 0.1μW

Status Bits and Alarm/Warning Flag Bits (2 Wire Address A2H)

| Address | Bit | Name | Description |
|---------|-----|------------------|--|
| 110 | 7 | TX Disable State | Digital state of TX disable (1) and enabled (0) |
| 110 | 6 | Soft TX Disable | Not implemented |
| 110 | 5-3 | Reserved | |
| 110 | 2 | TX Fault State | 1=TX failure state, 0=TX normal state |
| 110 | 1 | LOS | Digital state of LOS output pin. 0=optical signal detected, 1=no optical signal detected |
| 110 | 0 | Data_Ready_Bar | Not implemented. |
| 111 | 7-0 | Reserved | Reserved |
| 112 | 7 | Temp High Alarm | Set when internal temperature exceeds high alarm |

| | | | |
|---------|-----|-----------------------|--|
| | | | level. |
| 112 | 6 | Temp Low Alarm | Set when internal temperature is below low alarm level. |
| 112 | 5 | Vcc High Alarm | Set when internal supply voltage exceeds high alarm level. |
| 112 | 4 | Vcc Low Alarm | Set when internal supply voltage is below low alarm level. |
| 112 | 3 | TX Bias High Alarm | Set when TX Bias current exceeds high alarm level. |
| 112 | 2 | TX Bias Low Alarm | Set when TX Bias current is below low alarm level. |
| 112 | 1 | TX Power High Alarm | Set when TX Power exceeds high alarm level. |
| 112 | 0 | TX Power Low Alarm | Set when TX Power is below low alarm level. |
| 113 | 7 | RX Power High Alarm | Set when Received Power exceeds high alarm level. |
| 113 | 6 | RX Power Low Alarm | Set when Received Power is below low alarm level. |
| 113 | 5-0 | Reserved Alarm | |
| 114-115 | All | Reserved | |
| 116 | 7 | Temp High Warning | Set when internal temperature exceeds high warning level. |
| 116 | 6 | Temp Low Warning | Set when internal temperature is below low warning level. |
| 116 | 5 | Vcc High Warning | Set when internal supply voltage >high warning level. |
| 116 | 4 | Vcc Low Warning | Set when internal supply voltage < low warning level. |
| 116 | 3 | TX Bias High Warning | Set when TX Bias current exceeds high warning level. |
| 116 | 2 | TX Bias Low Warning | Set when TX Bias current is below low warning level. |
| 116 | 1 | TX Power High Warning | Set when TX Power exceeds high warning level. |
| 116 | 0 | TX Power Low Warning | Set when TX Power is below low warning level. |
| 117 | 7 | RX Power High Warning | Set when Received Power exceeds high warning level. |
| 117 | 6 | RX Power Low Warning | Set when Received Power is below low warning level. |
| 117 | 5-0 | Reserved Warning | |
| 118-119 | All | Reserved | |

Vendor Specific and User Accessible EEPROM (2 Wire Address A2H)

| Address | # Bytes | Name | Description |
|---------|---------|----------------------|--------------|
| 120-127 | 8 | Vendor Specific | Don't Access |
| 128-247 | 120 | User writable EEPROM | |
| 248-255 | 8 | Vendor Specific | Don't Access |

Recommend Circuit Schematic

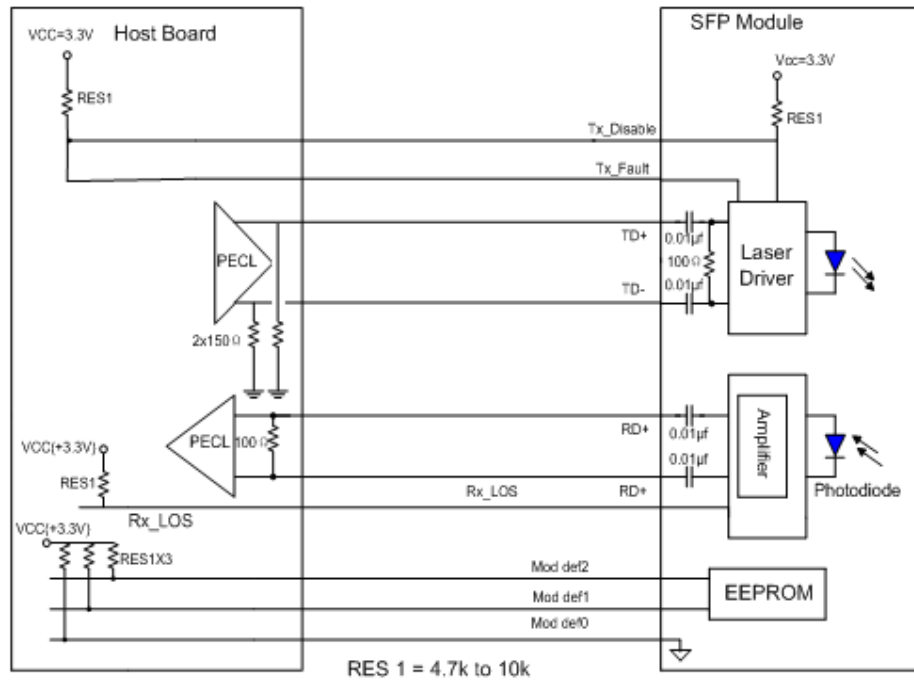

Mechanical Specifications

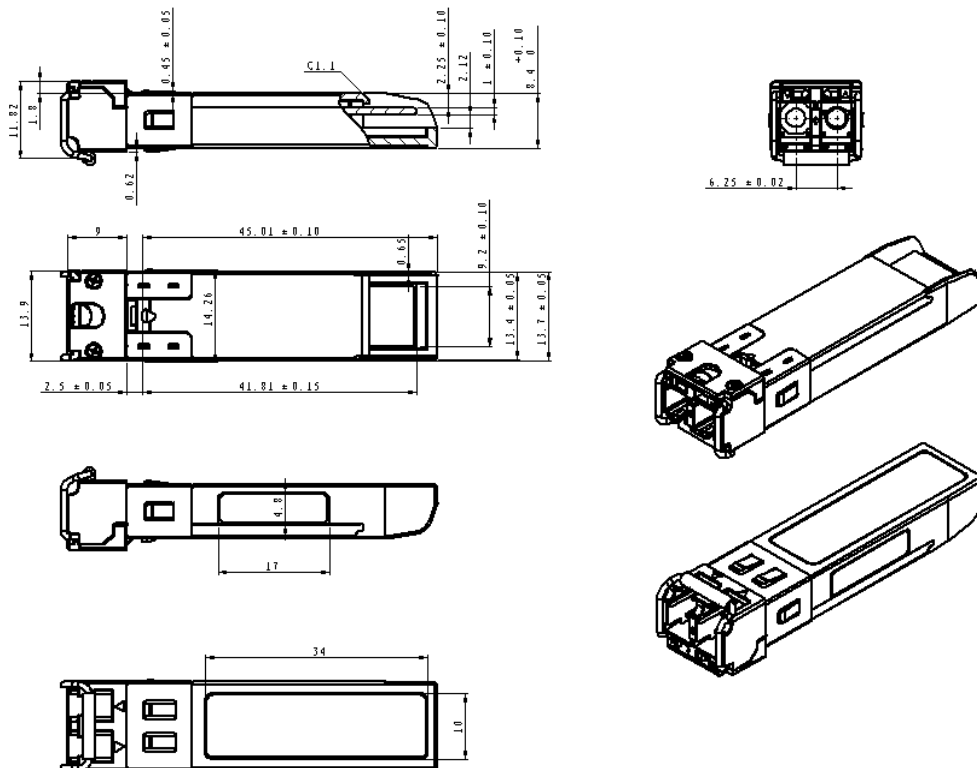

Class 1 Labels

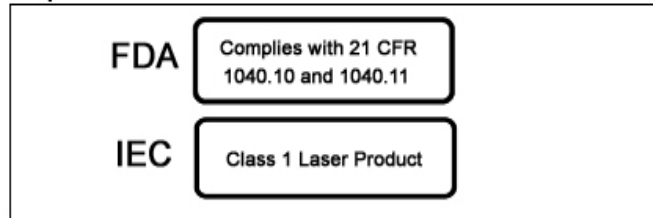

Laser Emission Data

| | |
|---|---------|
| Wavelength | >1260nm |
| Total output power (as defined by FDA: 7mm aperture at 20cm distance) | <0.79mW |
| Total output power (as defined by IEC: 7mm aperture at 10cm distance) | <10mW |
| Beam divergence | 12.5° |

Laser Emission

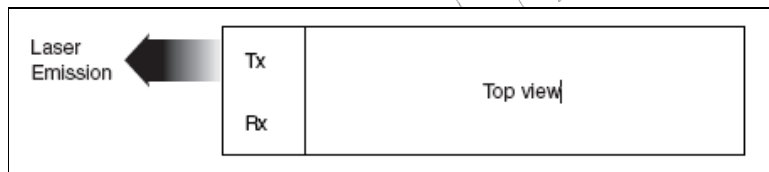

Obtaining Document

You can visit our website:

<http://www.eoptolink.com>

Or contact Eoptolink Technology Inc., Ltd. Listed at the end of the documentation to get the latest documents.

Revision History

| Revision | Initiated | Reviewed | Approved | Revision History | Release Date |
|----------|-----------|----------|----------|---|--------------|
| V1.a | Jacky | Kelly | | Released. | Sep 26, 2009 |
| V1.b | Jacky | Kelly | | Correct the PN in ordering information. | Sep 27, 2009 |
| V1.c | Kelly | | | Complete the CWDM wavelength & change logo. | Jan 20, 2010 |

Notice:

Eoptolink reserves the right to make changes to or discontinue any optical link product or service identified in this publication, without notice, in order to improve design and/or performance. Applications that are described herein for any of the optical link products are for illustrative purposes only. Eoptolink makes no representation or warranty that such applications will be suitable for the specified use without further testing or modification.

Contact:

Add: Floor 5, Building 2, No. 21 Gaopeng Avenue, High-Tech District, CHENGDU, SICHUAN
610041 P.R. CHINA

Tel: (+86) 028-85122709 ext 808 & 809

Fax: (+86) 028-85121912

Postal: 610041

E-mail: sales@eoptolink.com

<http://www.eoptolink.com>