

EOL2-1696-70-X Series

CWDM 10Gbit/s X2 Transceiver

RoHS6 Compliant

Features

- ◆ Compatible with X2 MSA Rev.2.0b
- ◆ Support of IEEE 802.3ae 10GBASE-LR at 10.3125Gbit/s
- ◆ Compliance to Fibre Channel 1200-SM-LL-L at 10.51875Gbit/s
- ◆ 8-Wavelengths CWDM EML Transmitter from 1470nm to 1610nm, with Step 20nm
- ◆ Low Power Consumption 2.0 W (typ.)
- ◆ Case Temperature Range:Standard: -5°C - 70°C
- ◆ Laser Class 1 compliant
- ◆ Duplex SC connector
- ◆ Hot pluggable 70-pin connector with XAU1 electrical interface
- ◆ Management and control via MDIO 2-wire interface
- ◆ Complaint with the EU RoHS 6 Environmental requirements



Applications

- ◆ 10G Ethernet

Ordering Information

Part No.	Data Rate	Laser	Fiber	Max. Distance ^{*(note2)}	Interface
EOL2-1696-70-X ₁ ^{*(note1)}	10G	CWDM EML	SMF	70km	SC

Note1: X₁ refers to CWDM Wavelength range 1470nm to 1610nm, X₂=47, 49, ... and 61;

Note2: The distance was measured at lab.

CWDM* Wavelength (0~70°C)

Band	Nomenclature	Wavelength(nm)		
		Min.	Typ.	Max.
S-band Short Wavelength	K	1464	1470	1477.5
	L	1484	1490	1497.5
	M	1504	1510	1517.5
	N	1524	1530	1537.5
C-band Conventional	O	1544	1550	1557.5
L-band Long Wavelength	P	1564	1570	1577.5
	Q	1584	1590	1597.5
	R	1604	1610	1617.5

CWDM*: 8 Wavelengths from 1470nm to 1610nm, each step 20nm.

Regulatory Compliance

Feature	Standard	Performance
Electrostatic Discharge (ESD) to the Electrical Pins	MIL-STD-883G Method 3015.7	Class 1C (>1000V)
Electrostatic Discharge to the Enclosure	EN 55024:1998+A1+A2 IEC-61000-4-2 GR-1089-CORE	Compliant with standards
Electromagnetic Interference (EMI)	FCC Part 15 Class B EN55022:2006 CISPR 22B :2006 VCCI Class B	Compliant with standards Noise frequency range: 30MHz to 6GHz. Good system EMI design practice required to achieve Class B margins. System margins are dependent on customer host board and chassis design.
Immunity	EN 55024:1998+A1+A2 IEC 61000-4-3	Compliant with standards. 1KHz sine-wave, 80% AM, from 80MHz to 1GHz. No effect on transmitter/receiver performance is detectable between these limits.
Laser Eye Safety	FDA 21CFR 1040.10 and 1040.11 EN (IEC) 60825-1:2007 EN (IEC) 60825-2:2004+A1	CDRH compliant and Class I laser product. TüV Certificate No. 50135086

Component Recognition	UL and CUL EN60950-1:2006	UL file E317337 TüV Certificate No. 50135086 (CB scheme)
RoHS6	2002/95/EC 4.1&4.2 2005/747/EC 5&7&13	Compliant with standards ^{*note3}

Note3: For update of the equipments and strict control of raw materials, EOPTOLINK has the ability to supply the customized products since Jan 1, 2007, which meet the requirements of RoHS6 (Restrictions on use of certain Hazardous Substances) of European Union.

In light of item 5 in RoHS exemption list of RoHS Directive 2002/95/EC, Item 5: Lead in glass of cathode ray tubes, electronic components and fluorescent tubes.

In light of item 13 in RoHS exemption list of RoHS Directive 2005/747/EC, Item13: Lead and cadmium in optical and filter glass. The three exemptions are being concerned for Eoptolink's transceivers, because Eoptolink's transceivers use glass, which may contain Pb, for components such as lenses, windows, isolators, and other electronic components.

Description

The EOL2-1696-70-X Series is highly integrated, serial optical transponder module for high-speed, 10Gbit/s data transmission applications. The module is fully compliant to IEEE 802.3ae standard for Ethernet, making it ideally suited for 10GbE datacom (rack to-rack, client interconnection) applications. The transponder module comprises a transmitter with a directly modulated CWDM EML laser, a receiver with a APD photodiode, a XAUI-Attachment Interface, an integrated Coder /Decoder and multiplexer / de-multiplexer (SERDES: Serializer/Deserializer).

The transponder operates within a wide case temperature range of -5°C to +70°C and offers optimum heat dissipation and excellent electromagnetic shielding which enables high port densities for 10GbE systems. A 70 pin electrical connector and a duplex SC connector optical interface assure that connectivity is compliant to the X2 and XENPAK MSA.

This module is designed for single mode fiber and operates at a nominal wavelength of CWDM wavelength. There are eight center wavelengths available from 1470nm to 1610nm, with each step 20nm. The maximum distance in lab is 70km.

Digital diagnostic monitoring (DDM) is implemented and fully compliant with X2 DDM architecture. The unit monitors temperature, receive optical power, transmit optical power, and laser bias current.

Absolute Maximum Ratings*

Rating	Symbol	Min	Max	Units
Storage Ambient Temperature	T _s	-40	+85	°C
Powered Case Temperature	T _c	-5	+70	°C
Supply Voltage 3.3V	V _{CC3}	-0.3	4.0	V
Supply Voltage 5V	V _{CC5}	-0.5	7.0	V
Input Voltage Low Speed Signals	V _I	-0.5	3.3	V
Clamp Currents Low Speed Signals	I _{IK}	-50		mA

XAUI Input Level	V_{IXAUI}	-0.4	2.3	V
Differential XAUI Input Amplitude	$ V_{IDXAUI} $		1000	mV
Optical Receiver Input Power	P_{Rx}		+1.5	dBm
Static Discharge Voltage			500	V

*Any stress beyond the maximum ratings can result in permanent damage permanently. The device specifications are guaranteed only under the recommended operating conditions.

Recommended Operating Conditions

Parameter	Symbol	Min	Typ	Max	Units
Operating Case Temperature Range	T_c	-5		+70	°C
Operating Humidity		8		80	%
Power Supply Voltage @ 3.3V	V_{CC3}	3.135	3.3	3.465	V
Power Supply Voltage @ 5.0V	V_{CC5}	4.75	5.00	5.25	V

Electrical Characteristics

Parameter	Symbol	Min	Typ	Max	Units
5V Supply Current	I_{VCC5}			350	mA
3.3V Supply Current	I_{VCC3}	310	360	576	mA

XAUI Input Characteristics ^{*Note4}

Parameter	Conditions	Symbol	Min	Typ	Max	Units
Data Rate	10GBASE-LR module			3.125		GBd
	1200-SM-LL-L module			3.1875		GBd
	Relative Tolerance		-100		+100	ppm
Differential Input Voltage Swing	8B/10B Coded Input Signal	V_{ID}	175		2,000	mV _{P-P}
Differential Return Loss	100MHz — 2.5GHz	SDD11	10			dB
Common Mode Return Loss	100MHz — 2.5GHz	SCC11	6			dB
Total Peak-to-Peak Jitter Tolerance	Sinusoidal Jitter @ 0~20MHz	T_{JRDS}	0.32			UI
Differential Input Impedance		R_{IND}	80	100	120	Ω

Note4: XAUI-input-Lanes are ac-inputs.

XAUI Output Characteristics ^{*Note5}

Parameter	Conditions	Symbol	Min	Typ	Max	Units
XAUI Data Rate	10GBASE-LR module			3.125		GBd
	1200-SM-LL-L module			3.1875		GBd
	XAUI Data Rate Tolerance		-100		+100	ppm

Differential Output Voltage Swing	$R_{LOAD}=100 \pm 5\%$	V_{out}	800		1,600	mV _{P-P}
Differential Output Impedance		Z_{out}	80	100	120	Ω
Differential Transition Time	20% - 80%	tr/tf	50		130	ps
Total Output Jitter					0.17	UI
Total Deterministic Output Jitter					0.08	UI

Note5: XAUI-output-Lanes are ac-outputs.

Optical Interface

Recommended Operating Conditions

Parameter	Remark	Symbol	Min	Typ	Max	Units
Input Data Rate	10GBASE-LR module	DRo		10.3125		Gbd
	1200-SM-LL-L module			10.51875		GBd
	relative tolerance	ADR/DRtyp	-100		+100	ppm
Receiver Input Signal	Center Wavelength	λ_c	1260		1600	nm
	Average Input Power	P_{IN}	1		3	dBm

Transmitter Characteristics

(If not otherwise mentioned under recommended operating conditions and standard compliant single mode fiber.)

Characteristic	Conditions	Symbol	Min	Typ	Max	Units
Data Rate	10GBASE-LR module			10.3125		Gbps
	1200-SM-LL-L module			10.51875		Gbps
	Relative tolerance to nominal DR	ADR/DRtyp p	-100		100	ppm
SMSR		SMSR	32			dB
Optical Output Power		P_{out}	1		5	dBm
Extinction Ratio	EOL	ER	3.5			dB
Optical Modulation Amplitude		OMA	500			pW
Transmitter Penalty	Bessel-Thompson Filter	TP			3	dB
Overshoot	Bessel-Thompson Filter	O_s			40	%

Receiver Characteristics ^{*Note6}

(If not otherwise mentioned under recommended operating conditions and standard compliant single mode fiber.)

Parameter	Conditions	Symbol	Min	Typ	Max	Units
Data Rate	10GBASE-LR module			10.3125		Gbps
	1200-SM-LL-L module			10.51875		Gbps
	Relative tolerance to nominal DR	ADR/DR _{typ}	-100		100	ppm
Receiver Sensitivity	OMA, BER 10^{-12} @ $2^{31}-1$	P _{min,OMA}			-23	dBm
Saturation Input Power		P _{max}	-9			dBm

Note6: The specified characteristics are met within the recommended range of operating conditions and under the default settings of output power and modulation amplitude. Changing the settings of the optical output power will affect the dynamic behavior of the output signal. Unless otherwise noted, typical data is quoted at nominal voltages and +25°C ambient temperature.

MDIO Interface

DC Characteristics

(If not otherwise mentioned under the recommended operating conditions.)

Characteristic	Condition	Symbol	Minimum	Maximum	Unit
Input high voltage		V _H	0.84	1.5	V
Input low voltage		V _L	-0.3	0.36	V
MDIO Input current	MMD Driver in tri-state	I _{MDIO}	-10	8	pA
MDC Input current		I _{MDC}	-5	5	pA
Output low voltage	I _{OL} = 100pA	V _{QL}	-0.3		V
	I _{OL} = 4mA	V _{QL}		0.2	V
Output high voltage	R _{PULL-Up} = 357Ω ±1% V _{PULL-Up} = 1.14~1.5V	V _{QH}	1.136	1.5	V
Output low current	V _I = 0.2V	I _{QL}	+4		mA
MDIO Input capacitance	V _I = 0~1.5V	C _{in}		10	pF

AC Characteristics

If not otherwise mentioned under the recommended operating conditions. Furthermore it's recommended that clock period time T_{MDC} is not less than 310ns and the sum of input currents of loads on the bus does not exceed 256pA at high and at low not below -320pA.

Characteristic	Condition	Symbol	Minimum	Maximum	Unit
Set Up Time		t _{set}		10	ns
Hold Time		t _{hold}		10	ns
Clock to Data Time	R _{PULL-Up} = 357Ω ±1%, C _{BUS} ≤ 470pF	t _{C2D}	0	300	ns

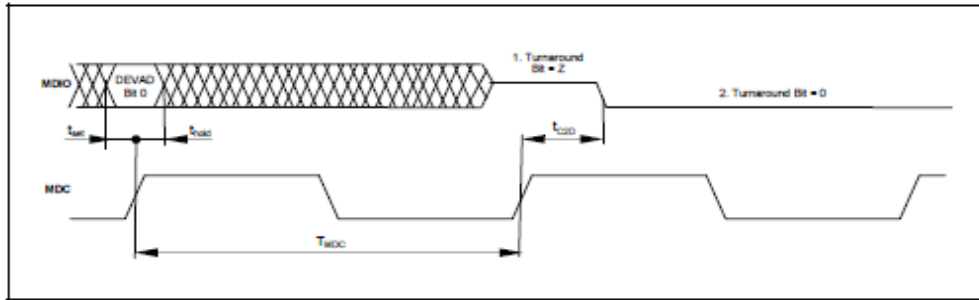

Example Timing Diagram: Turnover Timing at Read Cycle

Electro Static Discharge (ESD)

The maximum electrostatic charge based on a human body model and the conditions as outlined below is:

Parameter	Conditions	Symbol	Min	Typ	Max	Units
Static Discharge Voltage	MIL STD 883 Method				500	V

Thermal Management

The transponder is designed for an operation within a case temperature range between -5 to +70°C at an altitude of < 3km. The built in heatsink provides an optimized thermal performance. The user needs to guarantee per system design not to exceed this temperature range. It has to be considered that in case of usage of multiple modules on a single hostboard that there is a temperature rise among the modules hosted side by side (see figure below). Airflow direction and air speed needs to be chosen accordingly. For further information it is referred to the MSA document.

DDM Monitoring Specification

Parameter	Range	Accuracy	Calibration
Temperature	-10 to +80°C	± 3°C	Internal
Bias Current	0 to 100mA	±10%	Internal
TX Power	0 to +4dBm	± 3dB	Internal
RX Power	-24 to -8dBm	± 3dB	Internal

Card-Edge-Connector-Pinning and Layout



Top view - Top side

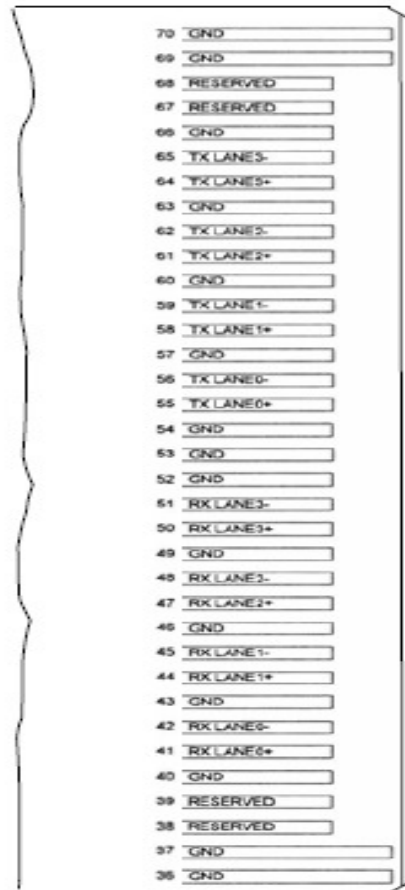

Top view - Bottom row

Electrical Pin Definition

Symbol	Logic	PIN	Name/Description	Note
3.3V		5, 6, 30, 31	Power Supply of Optical Receiver and Transmitter and Control Circuits	2
5.0V		4, 32	Power Supply of Optical Receiver Frontend	2
APS		7, 8, 28, 29	Adaptive Power Supply, Supply of PHY XS and PCS Layer Devices	2
APS SENSE		27	APS Sense Output for APS Control Circuit	
APS SET		25	Feedback Input for APS, Input of APS Setting Resistor	
GND		1, 2, 3, 33, 34, 35, 36, 37, 40, 43, 46, 49, 52,	Common Electrical Ground	1

		53, 54, 57, 60, 63, 66, 69, 70		
LASI	1.2V CMOS Open Drain Output	9	Link Alarm Status Interrupt, low active, Open Drain Output Supposed to operate with 10K Ω - 22K Ω pull upon host. Logic High: Normal Operation Logic Low: Link Alarm is indicated	
MDC		18	Management Clock Input	3
MDIO		17	Management Data IO	3
MOD DETECT		14	1k Ω to Ground for APS Circuit Environment	
PRTADO	1.2V CMOS Input	23	Port Address Bit 0 (Low = 0), internally pulled up by 18k Ω	
PRTAD1	1.2V CMOS Input	22	Port Address Bit 1 (Low = 0), internally pulled up by 18k Ω	
PRTAD2	1.2V CMOS Input	21	Port Address Bit 2 (Low = 0), internally pulled up by 18k Ω	
PRTAD3	1.2V CMOS Input	20	Port Address Bit 3 (Low = 0), internally pulled up by 18k Ω	
PRTAD4	1.2V CMOS Input	19	Port Address Bit 4 (Low = 0), internally pulled up by 18k Ω	
RESERVED		13, 38, 39, 67, 68	Reserved by MSA, internally not connected	
RESERVED		26	Reserved for Avalanche Photodiode use, internally not connected	5
RESET	1.2V CMOS Input	10	Low active Reset Input 10K Ω pull-up on Transceiver Logic high = Normal Operation Logic Low = Reset asserted	
TX ON/OFF	1.2V CMOS Input	12	High active Transmitter Enable Input 10K Ω pull-up on Transceiver Logic high = Transmitter active (normal Operation) And Register Bit 1.9.0 set to low as well Logic Low = shut down of Transmitter	
VENDSPECIFIC		11, 15, 16, 24	Vendor Specific Pin,. for proper operation leave unconnected	5

RX LANE0+		41	Module XAUI Output Lane 0+	4
RX LANE0-		42	Module XAUI Output Lane 0-	4
RXLANE1+		44	Module XAUI Output Lane 1+	4
RXLANE1-		45	Module XAUI Output Lane 1-	4
RX LANE2+		47	Module XAUI Output Lane 2+	4
RX LANE2-		48	Module XAUI Output Lane 2-	4
RX LANE3+		50	Module XAUI Output Lane 3+	4
RX LANE3-		51	Module XAUI Output Lane 3-	4
TX LANE0+		55	Module XAUI Input Lane 0+	4
TX LANE0-		56	Module XAUI Input Lane 0-	4
TXLANE1+		58	Module XAUI Input Lane 1+	4
TXLANE1-		59	Module XAUI Input Lane 1-	4
TX LANE2+		61	Module XAUI Input Lane 2+	4
TX LANE2-		62	Module XAUI Input Lane 2-	4
TX LANE3+		64	Module XAUI Input Lane 3+	4
TX LANE3-		65	Module XAUI Input Lane 3-	4

- 1) Ground connections are common for TX and RX.
- 2) Each connector contact is rated at 0.5A.
- 3) MDIO and MDC timing must comply with IEEE 802.3ae clause 45.3.
- 4) XAUI output characteristics comply with IEEE 802.3ae clause 47.
- 5) Transceivers will be MSA compliant when no signals are present on the vendor specific pins.

Eye Safety

This laser based multimode transceiver is a Class **1** product. It complies with IEC 60825-1: 2007 and FDA performance standards for laser products (21 CFR 1040.10 and 1040.11) except for deviations pursuant to Laser Notice 50, dated June 24, 2007.

Laser Emission Data

Wavelength	>1460nm
Total output power (as defined by IEC: 7mm aperture at 70mm distance)	15.6mW
Beam divergence	14°

Laser Emission

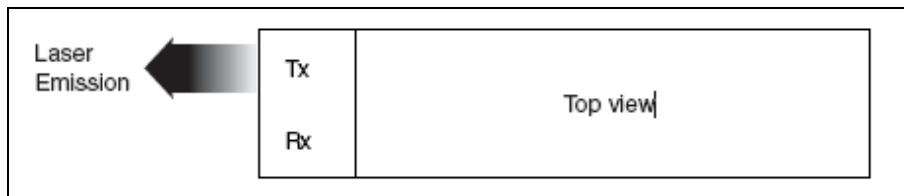

Mechanical Drawing

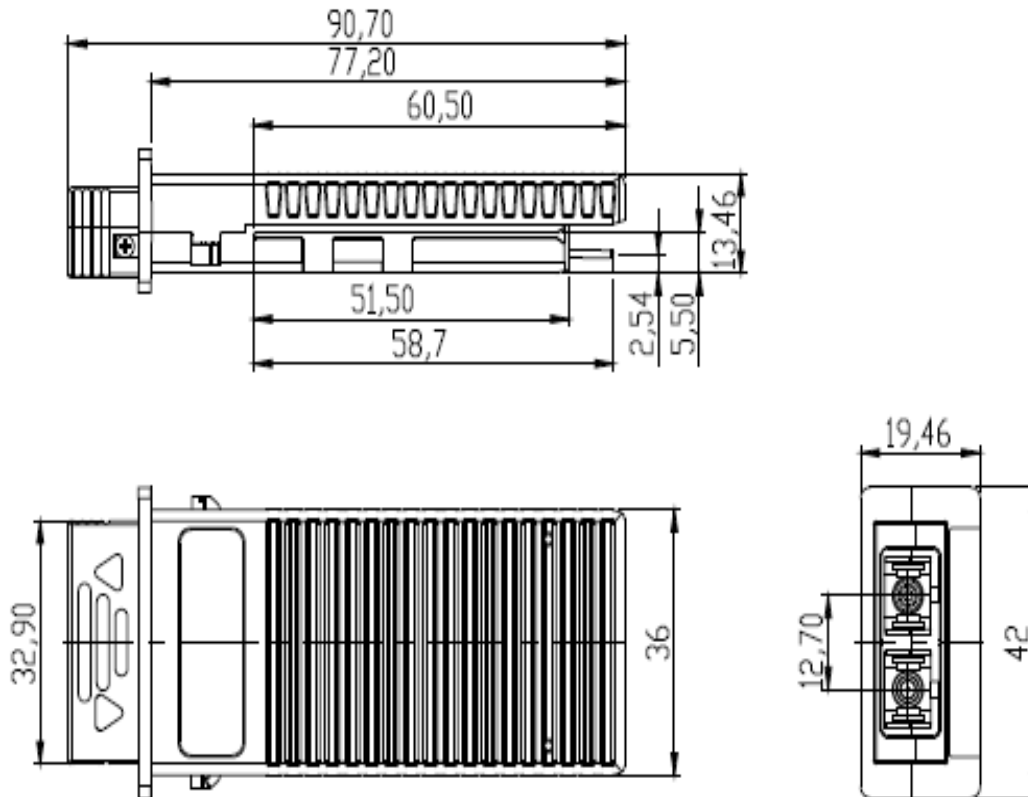

Obtaining Document

You can visit our website:

<http://www.eoptolink.com>

Or contact Eoptolink Technology Inc., Ltd. listed at the end of the documentation to get the latest documents.

Revision History

Revision	Initiated	Reviewed	Approved	Revision History	Release Date
V1.a	Jacky cheng	Kelly Cao		Released.	July 9, 2009
V1.b	Kelly.Cao			Updating PN & laser type.	Apr 22, 2010

Notice:

Eoptolink reserves the right to make changes to or discontinue any optical link product or service identified in this publication, without notice, in order to improve design and/or performance. Applications that are described herein for any of the optical link products are for illustrative purposes only. Eoptolink makes no representation or warranty that such applications will be suitable for the specified use without further testing or modification.

Contact:

Add: Floor 5, Building 2, No. 21 Gaopeng Avenue, High-Tech District, CHENGDU, SICHUAN
610041 P.R. CHINA

Tel: (+86) 028-85122709 ext 816 & 809

Fax: (+86) 028-85121912

Postal: 610041

E-mail: sales@eoptolink.com

<http://www.eoptolink.com>