

EOLX-1696-23X

CWDM XFP Single-Mode for 10GbE/10GFC/SDH/SONET
Duplex XFP Transceiver
RoHS6 Compliant

Features

- ◆ Supports 9.95Gb/s to 11.1Gb/s Bit Rates
- ◆ Hot-Pluggable XFP Footprint
- ◆ Compliant with XFP MSA
- ◆ 4-Wavelengths CWDM DFB Transmitter
from 1270nm to 1330nm, with Step 20nm
- ◆ 23dB Power Budget
- ◆ Duplex LC Connector
- ◆ Power Dissipation < 2.5W
- ◆ Case Operation Temperature Range
-5°C to 70°C
- ◆ 2-Wire Interface for Integrated Digital
Diagnostic Monitoring



Applications

- ◆ SONET OC-192 ER-1, SDH STM L-64.1
at 9.953Gbps
- ◆ 10GBASE-LR/LW 10G Ethernet
- ◆ 1200-SM-LL-L 10G Fiber Channel
- ◆ 10GE over G.709 at 11.09Gbps
- ◆ OC192 over FEC at 10.709Gbps

Ordering Information

Part No.	Data Rate	Laser	Fiber	Power Budget	Interface
EOLX-1696-23X ^{*(note1)}	10G	CWDM DFB	SMF	≥23dB	LC

Note1: X refers to CWDM Wavelength range 1470nm to 1610nm, X=A, B,C and D;

CWDM* Wavelength (0~70°C)

Nomenclature	Wavelength(nm)		
	Min.	Typ.	Max.
A	1264	1270	1277.5
B	1284	1290	1297.5
C	1304	1310	1317.5
D	1324	1330	1337.5

CWDM*: 4 Wavelengths from 1270nm to 1330nm, each step 20nm.

Regulatory Compliance

Feature	Standard	Performance
Electrostatic Discharge (ESD) to the Electrical Pins	MIL-STD-883G Method 3015.7	Class 1C (>1000 V)
Electrostatic Discharge to the Enclosure	EN 55024:1998+A1+A2 IEC-61000-4-2 GR-1089-CORE	Compliant with standards
Electromagnetic Interference (EMI)	FCC Part 15 Class B EN55022: 2006 CISPR 22B: 2006 VCCI Class B	Compliant with standards Noise frequency range: 30MHz to 6GHz. Good system EMI design practice required to achieve Class B margins. System margins are dependent on customer host board and chassis design.
Immunity	EN 55024:1998+A1+A2 IEC 61000-4-3	Compliant with standards. 1KHz sine-wave, 80% AM, from 80MHz to 1GHz. No effect on transmitter/receiver performance is detectable between these limits.
Laser Eye Safety	FDA 21CFR 1040.10 and 1040.11 EN (IEC) 60825-1: 2007 EN (IEC) 60825-2: 2004+A1	CDRH compliant and Class I laser product. TüV Certificate No. 50135086
Component Recognition	UL and CUL EN60950-1: 2006	UL file E317337 TüV Certificate No. 50135086 (CB scheme)
RoHS6	2002/95/EC 4.1&4.2 2005/747/EC 5&7&13	Compliant with standards ^{*note3}

Note3: For update of the equipments and strict control of raw materials, EOPTOLINK has the ability to supply the customized products since Jan 1st, 2007, which meet the requirements of RoHS6 (Restrictions on use of certain Hazardous Substances) of European Union.

In light of item 5 in RoHS exemption list of RoHS Directive 2002/95/EC, Item 5: Lead in glass of cathode ray tubes, electronic components and fluorescent tubes.

In light of item 13 in RoHS exemption list of RoHS Directive 2005/747/EC, Item 13: Lead and cadmium in optical and filter glass. The three exemptions are being concerned for Eoptolink's transceivers, because Eoptolink's transceivers use glass, which may contain Pb, for components such as lenses, solators, and other components.

Product Description

The EOLX-1696-23X series optical transceiver is designed for fiber communications application such as SONET OC-192, STM-64, 10G Ethernet (10GBASE-ER/EW) and 10G Fiber Channel (1200-SM-LL-L), which fully compliant with the specification of XFP MSA Rev 4.5.

This module is designed for single mode fiber and operates at a nominal wavelength of CWDM wavelength. There are four center wavelengths available from 1270nm to 1330nm, with each step 20nm.

The module is with the XFP 30-pin connector to allow hot plug capability. Only single 3.3V power supply is needed. The optical output can be disabled by LVTTTL logic high-level input of TX_DIS. Loss of signal (RX_LOS) output is provided to indicate the loss of an input optical signal of receiver.

This module provides digital diagnostic functions via a 2-wire serial interface as defined by the XFP MSA Rev 4.5.

Absolute Maximum Ratings

Parameter	Symbol	Min	Typical	Max	Unit	Note
Maximum Supply Voltage	V _{CC}	-0.5		4.0	V	
Storage Temperature	T _S	-40		85	°C	
Case Operating Temperature	T _{OP}	-5		70	°C	
Maximum Input Power	P _m			-8	dBm	

Recommend Operating Condition

Parameter	Symbol	Min	Typical	Max	Units	Note
Operating Temperature	T _{OP}	-5		70	°C	
Supply Voltage	V _{CC}	3.13	3.3	3.45	V	
Supply Current	I _{CC}			750	mA	
Module Total Power	P			2.5	W	

Electrical Characteristics

($T_{OP} = -5$ to $70^{\circ}C$, $V_{CC} = 3.15$ to $3.45V$)

Parameter	Symbol	Min	Typical	Max	Unit	Note	
Transmitter							
Input Differential Impedance	R _{in}		100		Ω	1	
Differential Data Input Swing	V _{in} , pp	180		820	mV		
Transmit Disable Voltage	V _{DIS}	2.0		V _{CC}	V		
Transmit Enable Voltage	V _{EN}	GND		GND+ 0.8	V		
Transmit Disable Assert Time				10	us		
Receiver							
Differential Data Output Swing	V _{out} , pp	340	650	850	mV		
Data Output Rise Time	t _r			38	ps	2	
Data Output Fall Time	t _f			38	ps	2	
LOS Fault	V _{LOS fault}	V _{CC} -0.5		V _{CC HOST}	V	3	
LOS Normal	V _{LOS norm}	GND		GND+0.5	V	3	
Power Supply Rejection	PSR	See Note 4 below					4

Notes:

1. After internal AC coupling.
2. 20 – 80 %.
3. Loss of Signal is open collector to be pulled up with a 4.7k – 10kohm resistor to 3.15 – 3.6V.
Logic 0 indicates normal operation; logic 1 indicates no signal detected.
4. Reference the Section 2.7 of the XFP MSA Rev 4.5.

Optical Characteristics

($T_{OP} = -5$ to $70^{\circ}C$, $V_{CC} = 3.15$ to $3.45V$)

Parameter	Symbol	Min	Typical	Max	Unit	Note
Transmitter						
Output Opt. Pwr: 9/125 SMF	P _{out}	0		4	dBm	1
Optical Extinction Ratio	ER	3.5			dB	
Optical Wavelength	λ	λ _C -6	λ _C	λ _C +7.5	nm	2
-20dB Spectrum Width	Δλ			1	nm	
Side Mode Suppression Ratio	SMSR	32			dB	
Average Launch Power of OFF Transmitter	P _{OFF}			-30	dBm	
TX Jitter	TX _j	Per 802.3ae requirements				
Relative Intensity Noise	RIN			-135	dB/Hz	
Receiver						

Receiver Sensitivity @ 10.3125Gb/s	Pmin			-23	dBm	3
Overload Power	Pmax	-10			dBm	
Optical Center Wavelength	λ	1260		1600	nm	
Receiver Reflectance	Rrf			-12	dB	
LOS De-Assert	LOS _D			-23	dBm	
LOS Assert	LOS _A	-28			dBm	
LOS Hysteresis		1			dB	

Notes:

1. Output power is coupled into a 9/125 μ m SMF.
2. ITU-T G.694.2 CWDM wavelength from 1270nm to 1330nm, each step 20nm.
3. Average received power; BER less than 1E-12 and PRBS 2³¹-1 test pattern.

Pin Descriptions

Pin	Logic	Symbol	Name/Description	Notes
1		GND	Module Ground	1
2		VEE5	Optional -5.2 Power Supply – Not Required	
3	LVTTL-I	Mod-Desel	Module De-select; When held low allows the module to respond to 2-wire serial interface commands	
4	LVTTL-O	/Interrupt	/Interrupt; Indicates presence of an important condition which can be read over the serial 2-wire interface	2
5	LVTTL-I	TX_DIS	Transmitter Disable; Transmitter laser source turned off	
6		VCC5	+5 Power Supply - Not Required	
7		GND	Module Ground	1
8		VCC3	+3.3V Power Supply	
9		VCC3	+3.3V Power Supply	
10	LVTTL-I	SCL	Serial 2-wire interface clock	2
11	LVTTL-I/O	SDA	Serial 2-wire interface data line	2
12	LVTTL-O	Mod_Abs	Module Absent; Indicates module is not present. Grounded in the module.	2
13	LVTTL-O	Mod_NR	Module Not Ready;	2
14	LVTTL-O	RX_LOS	Receiver Loss of Signal indicator	2
15		GND	Module Ground	1
16		GND	Module Ground	1
17	CML-O	RD-	Receiver inverted data output	
18	CML-O	RD+	Receiver non-inverted data output	

19		GND	Module Ground	1
20		VCC2	+1.8V Power Supply – Not required	
21	LVTTTL-I	P_Down/RST	Power Down; When high, places the module in the low power stand-by mode and on the falling edge of P_Down initiates a module reset	
			Reset; The falling edge initiates a complete reset of the module including the 2-wire serial interface, equivalent to a power cycle.	
22		VCC2	+1.8V Power Supply – Not required	
23		GND	Module Ground	1
24	PECL-I	RefCLK+	Reference Clock non-inverted input, AC coupled on the host board – Not required	3
25	PECL-I	RefCLK-	Reference Clock inverted input, AC coupled on the host board – Not required	3
26		GND	Module Ground	1
27		GND	Module Ground	1
28	CML-I	TD-	Transmitter inverted data input	
29	CML-I	TD+	Transmitter non-inverted data input	
30		GND	Module Ground	1

Notes:

1. Module circuit ground is isolated from module chassis ground within the module.
2. Open connect should be pulled up with 4.7k – 10k ohm on host board to a voltage between 3.15V and 3.6V.
3. A Reference Clock input is not required.

Pin Arrangement

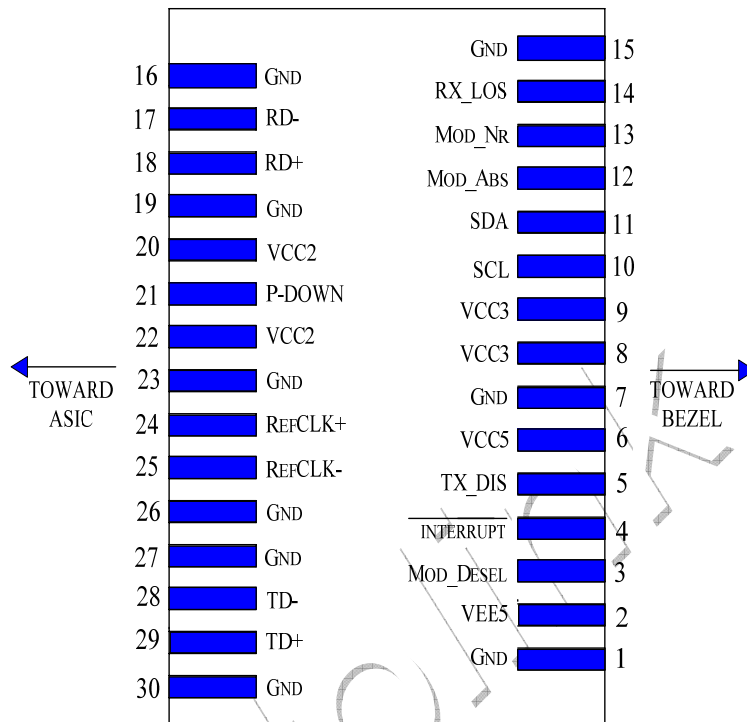

General Specifications

Parameter	Symbol	Min	Typical	Max	Units	Note
Bit Rate	BR	9.95		11.1	Gb/s	
Bit Error Ratio	BER			10 ⁻¹²		1

Notes:

1. Tested 9.95G with 2³¹ – 1 PRBS pattern.

Digital Diagnostic Functions

Eoptolink's Small Form Factor 10Gbps (XFP) transceiver is compliant with the current XFP Multi-Source Agreement (MSA) Specification Rev 4.5.

As defined by the XFP MSA, Eoptolink XFP transceivers provide digital diagnostic functions via a 2-wire serial interface, which allows real-time access to the following operating parameters:

- ◆ Transceiver temperature
- ◆ Laser bias current
- ◆ Transmitted optical power
- ◆ Received optical power
- ◆ Aux Monitoring

It also provides a sophisticated system of alarm and warning flags, which may be used to alert

end-users when particular operating parameters are outside of a factory-set normal range.

The operating and diagnostics information is monitored and reported by a Digital Diagnostics Transceiver Controller inside the transceiver, which is accessed through the 2-wire serial interface. The serial data signal (SDA pin) is bi-directional for serial data transfer. The host uses SDA in conjunction with SCL to mark the start and end of serial protocol activation. The memories are organized as a series of 8-bit data words that can be addressed individually or sequentially. The 2-wire serial interface provides sequential or random access to the 8 bit parameters, addressed from 00h to the maximum address of the memory.

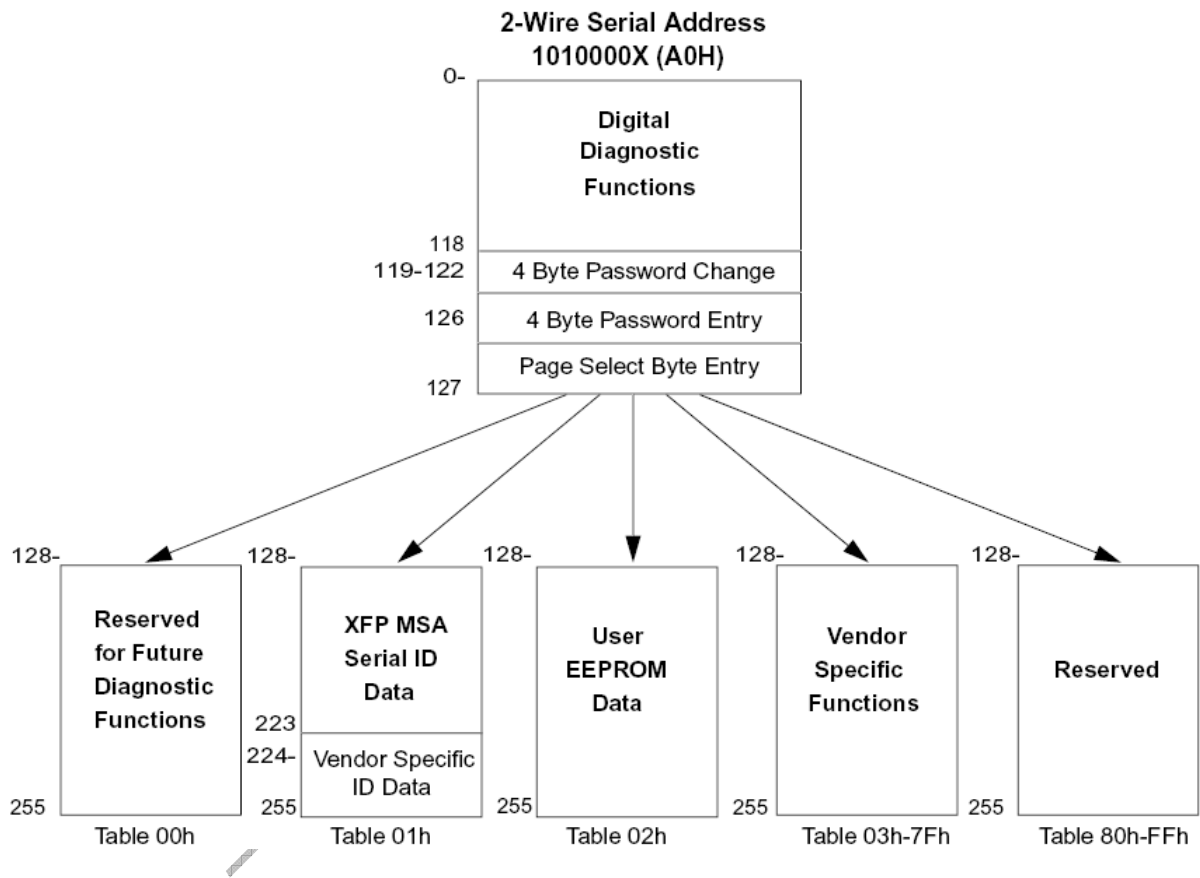

Recommended Host Board Power Supply Circuit

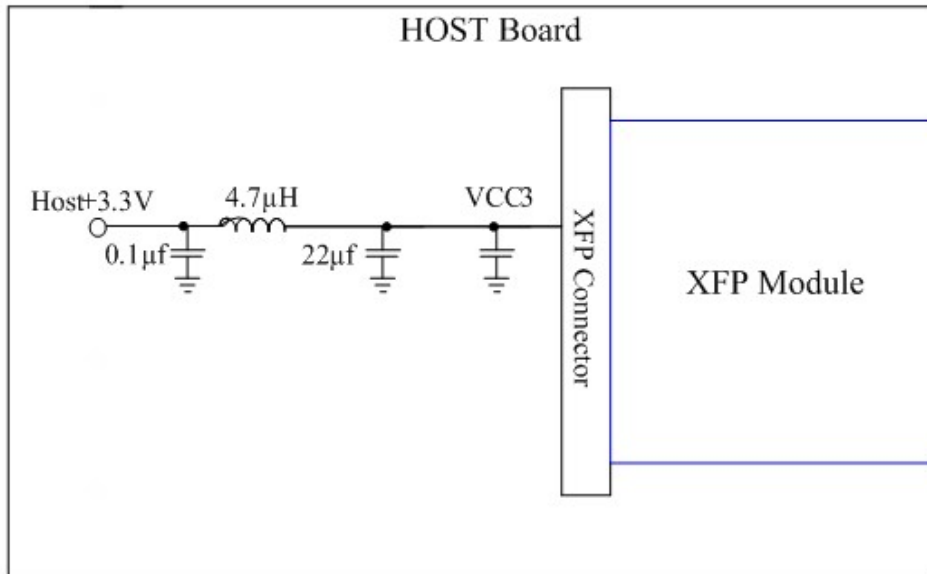

Recommended High-Speed Interface Circuit

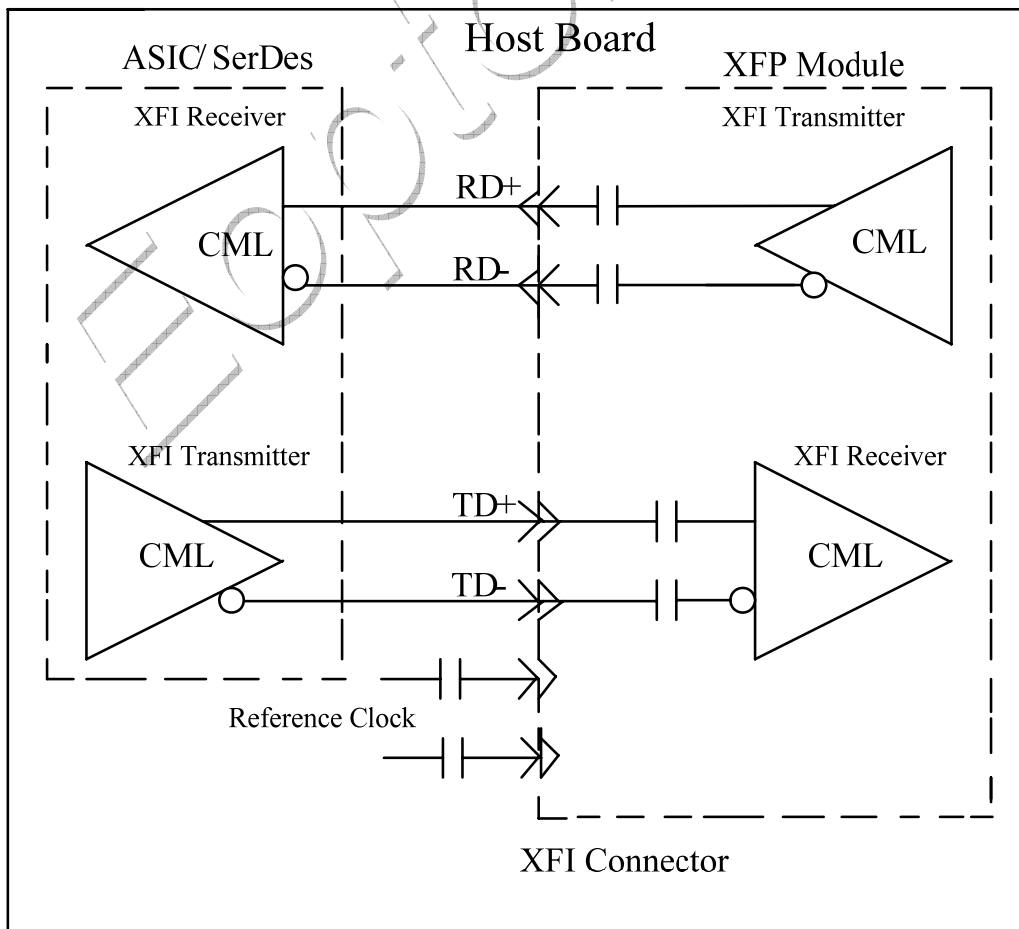

Mechanical Specifications

Eoptolink's XFP transceivers are compliant with the dimensions defined by the XFP Multi-Sourcing Agreement (MSA).

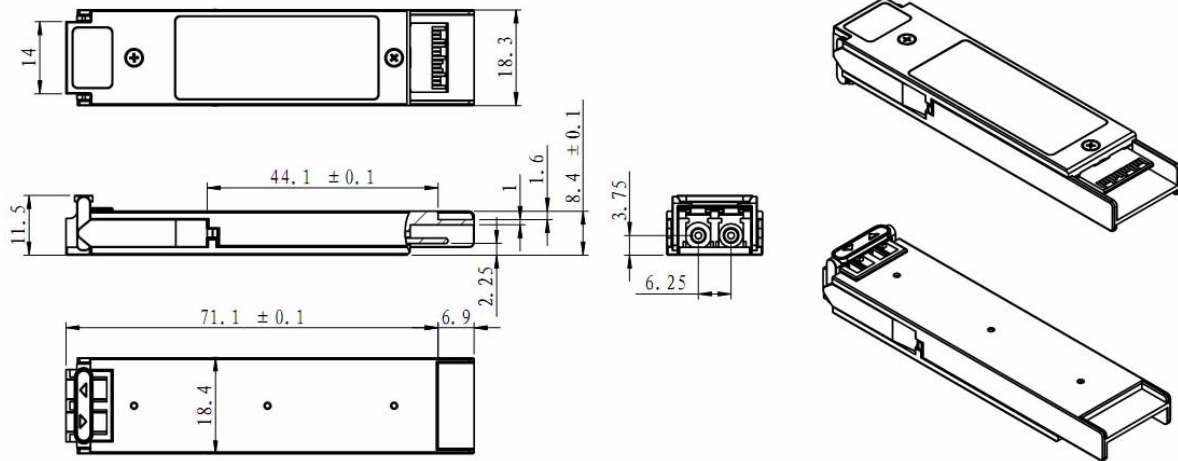

Eye Safety

This single-mode transceiver is a Class 1 laser product. It complies with IEC-60825 and FDA 21 CFR 1040.10 and 1040.11. The transceiver must be operated within the specified temperature and voltage limits. The optical ports of the module shall be terminated with an optical connector or with a dust plug.

Obtaining Document

You can visit our website:

<http://www.eoptolink.com>

Or contact Eoptolink Technology Inc., Ltd. listed at the end of the documentation to get the latest documents.

Revision History

Revision	Initiated	Reviewed	Approved	Revision History	Release Date
V1.a	Kelly.Cao			Released.	July 22, 2011

Notice:

Eoptolink reserves the right to make changes to or discontinue any optical link product or service identified in this publication, without notice, in order to improve design and/or performance. Applications that are described herein for any of the optical link products are for illustrative purposes only. Eoptolink makes no representation or warranty that such applications will be suitable for the specified use without further testing or modification.

Contact:

Add: Floor 5, Building 2, No. 21 Gaopeng Avenue, High-Tech District, CHENGDU, SICHUAN
610041 P.R. CHINA

Tel: (+86) 028-85122709 ext 816 & 809

Fax: (+86) 028-85121912

Postal: 610041

E-mail: sales@eoptolink.com

<http://www.eoptolink.com>