

EOLX-1696-10-X

**CWDM XFP Single-Mode for 10GbE/10GFC/SDH/SONET
Duplex XFP Transceiver
RoHS6 Compliant**

Features

- ◆ Supports 9.95Gb/s to 11.1Gb/s Bit Rates
- ◆ Hot-Pluggable XFP Footprint
- ◆ Compliant with XFP MSA
- ◆ 18-Wavelengths CWDM DFB Transmitter
from 1270nm to 1610nm, with Step 20nm
- ◆ 10dB power budget at least
- ◆ Duplex LC Connector
- ◆ Power Dissipation < 2.5W
- ◆ Case Operation Temperature Range
-5°C to 70°C
- ◆ 2-Wire Interface for Integrated Digital
Diagnostic Monitoring



Applications

- ◆ SONET OC-192 LR-1, SDH STM L-64.1
at 9.953Gbps
- ◆ 10GBASE-LR/LW 10G Ethernet
- ◆ 1200-SM-LL-L 10G Fiber Channel
- ◆ 10GE over G.709 at 11.09Gbps
- ◆ OC192 over FEC at 10.709Gbps

Ordering Information

| Part No. | Data Rate | Laser | Fiber | Distance | Interface |
|------------------------------------|-----------|-------------|-------|-------------------|-----------|
| EOLX-1696-10-X ^{*(note1)} | 10G | CWDM DFB | SMF | 10dB power budget | LC |

Note1: X refers to CWDM Wavelength range 1270nm to 1610nm, X=A, B, ... and R, for detailed definition, please refer the following table.

CWDM Wavelength (0~70C)

| Band | Nomenclature | Wavelength(nm) | | |
|-------------------------|--------------|----------------|------|--------|
| | | Min. | Typ. | Max. |
| O-band Original | A | 1264 | 1270 | 1277.5 |
| | B | 1284 | 1290 | 1297.5 |
| | C | 1304 | 1310 | 1317.5 |
| | D | 1324 | 1330 | 1337.5 |
| | E* | 1344 | 1350 | 1357.5 |
| E-band Extended | F* | 1364 | 1370 | 1377.5 |
| | G* | 1384 | 1390 | 1397.5 |
| | H* | 1404 | 1410 | 1417.5 |
| | I* | 1424 | 1430 | 1437.5 |
| | J* | 1444 | 1450 | 1457.5 |
| S-band Short Wavelength | K | 1464 | 1470 | 1477.5 |
| | L | 1484 | 1490 | 1497.5 |
| | M | 1504 | 1510 | 1517.5 |
| | N | 1524 | 1530 | 1537.5 |
| C-band Conventional | O | 1544 | 1550 | 1557.5 |
| L-band Long Wavelength | P | 1564 | 1570 | 1577.5 |
| | Q | 1584 | 1590 | 1597.5 |
| | R | 1604 | 1610 | 1617.5 |

*Please contact EOPTOLINK to confirm the six wavelengths from 1350nm to 1450nm, which may be not available.

Regulatory Compliance

| Feature | Standard | Performance |
|--|---|--|
| Electrostatic Discharge (ESD) to the Electrical Pins | MIL-STD-883G Method 3015.7 | Class 1C (>1000 V) |
| Electrostatic Discharge to the Enclosure | EN 55024:1998+A1+A2 IEC-61000-4-2 GR-1089-CORE | Compliant with standards |
| Electromagnetic Interference (EMI) | FCC Part 15 Class B EN55022: 2006 CISPR 22B: 2006 VCCI Class B | Compliant with standards Noise frequency range: 30MHz to 6GHz. Good system EMI design practice required to achieve Class B margins. System margins are dependent on customer host board and chassis design. |

| | | |
|-----------------------|--|--|
| Immunity | EN 55024:1998+A1+A2 IEC 61000-4-3 | Compliant with standards. 1KHz sine-wave, 80% AM, from 80MHz to 1GHz. No effect on transmitter/receiver performance is detectable between these limits. |
| Laser Eye Safety | FDA 21CFR 1040.10 and 1040.11 EN (IEC) 60825-1: 2007 EN (IEC) 60825-2: 2004+A1 | CDRH compliant and Class I laser product. TüV Certificate No. 50135086 |
| Component Recognition | UL and CUL EN60950-1: 2006 | UL file E317337 TüV Certificate No. 50135086 (CB scheme) |
| RoHS6 | 2002/95/EC 4.1&4.2 2005/747/EC 5&7&13 | Compliant with standards* ^{note3} |

Note2: For update of the equipments and strict control of raw materials, EOPTOLINK has the ability to supply the customized products since Jan 1st, 2007, which meet the requirements of RoHS6 (Restrictions on use of certain Hazardous Substances) of European Union.

In light of item 5 in RoHS exemption list of RoHS Directive 2002/95/EC, Item 5: Lead in glass of cathode ray tubes, electronic components and fluorescent tubes.

In light of item 13 in RoHS exemption list of RoHS Directive 2005/747/EC, Item 13: Lead and cadmium in optical and filter glass. The three exemptions are being concerned for Eoptolink's transceivers, because Eoptolink's transceivers use glass, which may contain Pb, for components such as lenses, solators, and other components.

Product Description

The EOLX-1696-10-X series optical transceiver is designed for fiber communications application such as 10G Ethernet (10GBASE-ER/EW) and 10G Fiber Channel (1200-SM-LL-L), which fully compliant with the specification of XFP MSA Rev 4.5.

This module is designed for single mode fiber and operates at a nominal wavelength of CWDM wavelength. There are twelve center wavelengths available from 1270nm to 1330nm and 1470nm to 1610nm, with each step 20nm. A guaranteed optical link budget of 10dB is offered.

The module is with the XFP 30-pin connector to allow hot plug capability. Only single 3.3V power supply is needed. The optical output can be disabled by LVTTTL logic high-level input of TX_DIS. Loss of signal (RX_LOS) output is provided to indicate the loss of an input optical signal of receiver. This module provides digital diagnostic functions via a 2-wire serial interface as defined by the XFP MSA Rev 4.5.

Absolute Maximum Ratings

| Parameter | Symbol | Min | Typical | Max | Unit | Note |
|------------------------|-----------------|------|---------|-----|------|------|
| Maximum Supply Voltage | V _{CC} | -0.5 | | 4.0 | V | |
| Storage Temperature | T _S | -40 | | 85 | °C | |
| Case Operating | T _{OP} | -20 | | 80 | °C | |

| | | | | | | |
|-------------|--|--|--|--|--|--|
| Temperature | | | | | | |
|-------------|--|--|--|--|--|--|

Recommend Operating Condition

| Parameter | Symbol | Min | Typical | Max | Units | Note |
|-----------------------|-----------------|------|---------|------|-------|------|
| Operating Temperature | T _{OP} | -5 | | 70 | °C | |
| Supply Voltage | V _{CC} | 3.13 | 3.3 | 3.45 | V | |
| Supply Current | I _{CC} | | | 750 | mA | |
| Module Total Power | P | | | 2.5 | W | |

Electrical Characteristics

(T_{OP} = -5 to 70°C, V_{CC} = 3.15 to 3.45V)

| Parameter | Symbol | Min | Typical | Max | Unit | Note |
|--------------------------------|------------------------|-----------------------|------------------|----------------------|------|------|
| Transmitter | | | | | | |
| Input Differential Impedance | R _{in} | | 100 | | Ω | 1 |
| Differential Data Input Swing | V _{in, pp} | 180 | | 820 | mV | |
| Transmit Disable Voltage | V _{DIS} | 2.0 | | V _{CC} | V | |
| Transmit Enable Voltage | V _{EN} | GND | | GND+ 0.8 | V | |
| Transmit Disable Assert Time | | | | 10 | us | |
| Receiver | | | | | | |
| Differential Data Output Swing | V _{out, pp} | 340 | 650 | 850 | mV | |
| Data Output Rise Time | t _r | | | 38 | ps | 2 |
| Data Output Fall Time | t _f | | | 38 | ps | 2 |
| LOS Fault | V _{LOS fault} | V _{CC} - 0.5 | | V _{CC HOST} | V | 3 |
| LOS Normal | V _{LOS norm} | GND | | GND+0.5 | V | 3 |
| Power Supply Rejection | PSR | | See Note 4 below | | | 4 |

Notes:

1. After internal AC coupling.
2. 20 – 80 %.
3. Loss of Signal is open collector to be pulled up with a 4.7k – 10kohm resistor to 3.15 – 3.6V.
Logic 0 indicates normal operation; logic 1 indicates no signal detected.
4. Reference the Section 2.7 of the XFP MSA Rev 4.5.

Optical Characteristics

(T_{OP} = -5 to 70°C, V_{CC} = 3.15 to 3.45V)

| Parameter | Symbol | Min | Typical | Max | Unit | Note |
|-----------------------------|------------------|-------------------|----------------|---------------------|------|------|
| Transmitter | | | | | | |
| Output Opt. Pwr: 9/125 SMF | P _{out} | -3 | | +1.0 | dBm | 1 |
| Optical Extinction Ratio | ER | 3.5 | | | dB | |
| Optical Wavelength | λ | λ _c -6 | λ _c | λ _c +7.5 | nm | 2 |
| -20dB Spectrum Width | Δλ | | | 1 | nm | |
| Side Mode Suppression Ratio | SMSR | 30 | | | dB | |

| | | | | | | |
|---|------------------|--------------------------|--|------|-------|---|
| Path Penalty | Pp | | | 2 | dB | |
| Average Launch Power of OFF Transmitter | P _{OFF} | | | -30 | dBm | |
| TX Jitter | TXj | Per 802.3ae requirements | | | | |
| Relative Intensity Noise | RIN | | | -128 | dB/Hz | |
| Receiver | | | | | | |
| Receiver Sensitivity @ 10.3125Gb/s | P _{min} | | | -13 | dBm | 3 |
| Maximum Input Power | P _{max} | +0.5 | | | dBm | |
| Optical Center Wavelength | λ | 1260 | | 1600 | nm | |
| Receiver Reflectance | R _{rf} | | | -12 | dB | |
| LOS De-Assert | LOS _D | | | -20 | dBm | |
| LOS Assert | LOS _A | -28 | | | dBm | |
| LOS Hysteresis | | 1 | | | dB | |

Notes:

1. Output is coupled into a 9/125μm SMF.
2. ITU-T G.694.2 CWDM wavelength from 1270nm to 1610nm, each step 20nm.
3. Average received power; BER less than 1E-12 and PRBS 2³¹-1 test pattern.

Pin Descriptions

| Pin | Logic | Symbol | Name/Description | Notes |
|-----|-----------|------------|---|-------|
| 1 | | GND | Module Ground | 1 |
| 2 | | VEE5 | Optional -5.2 Power Supply – Not Required | |
| 3 | LVTTL-I | Mod-Desel | Module De-select; When held low allows the module to respond to 2-wire serial interface commands | |
| 4 | LVTTL-O | /Interrupt | /Interrupt; Indicates presence of an important condition which can be read over the serial 2-wire interface | 2 |
| 5 | LVTTL-I | TX_DIS | Transmitter Disable; Transmitter laser source turned off | |
| 6 | | VCC5 | +5 Power Supply - Not Required | |
| 7 | | GND | Module Ground | 1 |
| 8 | | VCC3 | +3.3V Power Supply | |
| 9 | | VCC3 | +3.3V Power Supply | |
| 10 | LVTTL-I | SCL | Serial 2-wire interface clock | 2 |
| 11 | LVTTL-I/O | SDA | Serial 2-wire interface data line | 2 |
| 12 | LVTTL-O | Mod_Abs | Module Absent; Indicates module is not present. Grounded in the module. | 2 |

| | | | | |
|----|----------|----------------|--|---|
| 13 | LVTTTL-O | Mod_NR | Module Not Ready; | 2 |
| 14 | LVTTTL-O | RX_LOS | Receiver Loss of Signal indicator | 2 |
| 15 | | GND | Module Ground | 1 |
| 16 | | GND | Module Ground | 1 |
| 17 | CML-O | RD- | Receiver inverted data output | |
| 18 | CML-O | RD+ | Receiver non-inverted data output | |
| 19 | | GND | Module Ground | 1 |
| 20 | | VCC2 | +1.8V Power Supply – Not required | |
| 21 | LVTTTL-I | P_Down/R ST | Power Down; When high, places the module in the low power stand-by mode and on the falling edge of P_Down initiates a module reset | |
| | | | Reset; The falling edge initiates a complete reset of the module including the 2-wire serial interface, equivalent to a power cycle. | |
| 22 | | VCC2 | +1.8V Power Supply – Not required | |
| 23 | | GND | Module Ground | 1 |
| 24 | PECL-I | RefCLK+ | Reference Clock non-inverted input, AC coupled on the host board – Not required | 3 |
| 25 | PECL-I | RefCLK- | Reference Clock inverted input, AC coupled on the host board – Not required | 3 |
| 26 | | GND | Module Ground | 1 |
| 27 | | GND | Module Ground | 1 |
| 28 | CML-I | TD- | Transmitter inverted data input | |
| 29 | CML-I | TD+ | Transmitter non-inverted data input | |
| 30 | | GND | Module Ground | 1 |

Notes:

1. Module circuit ground is isolated from module chassis ground within the module.
2. Open connect should be pulled up with 4.7k – 10k ohm on host board to a voltage between 3.15V and 3.6V.
3. A Reference Clock input is not required.

Host Board Connector Pin Out

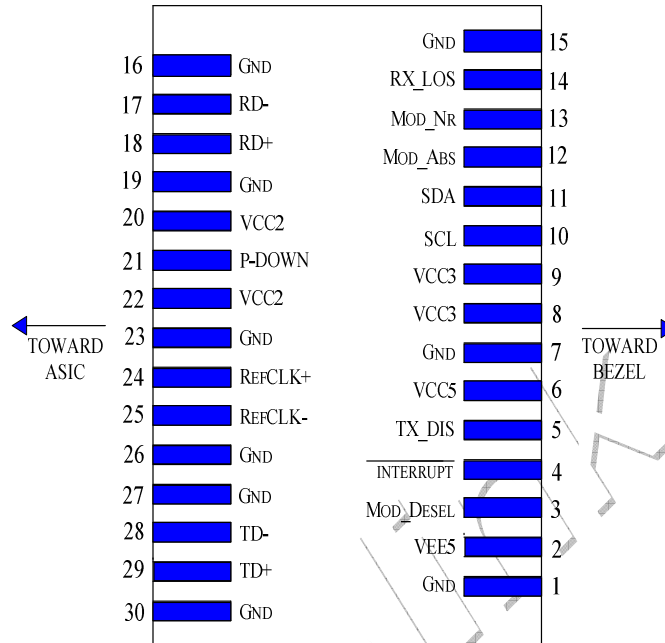

Diagram of Host Board Connector Block Pin Numbers and Name

General Specifications

| Parameter | Symbol | Min | Typical | Max | Units | Note |
|-----------------|--------|------|---------|------------|-------|------|
| Bit Rate | BR | 9.95 | | 11.1 | Gb/s | |
| Bit Error Ratio | BER | | | 10^{-12} | | 1 |

Notes:

1. Tested 9.95G with $2^{31} - 1$ PRBS pattern.

Digital Diagnostic Functions

Eoptolink's Small Form Factor 10Gbps (XFP) transceiver is compliant with the current XFP Multi-Source Agreement (MSA) Specification Rev 4.5.

As defined by the XFP MSA, Eoptolink XFP transceivers provide digital diagnostic functions via a 2-wire serial interface, which allows real-time access to the following operating parameters:

- ◆ Transceiver temperature
- ◆ Laser bias current
- ◆ Transmitted optical power
- ◆ Received optical power
- ◆ Aux Monitoring

It also provides a sophisticated system of alarm and warning flags, which may be used to alert end-users when particular operating parameters are outside of a factory-set normal range.

The operating and diagnostics information is monitored and reported by a Digital Diagnostics

Transceiver Controller inside the transceiver, which is accessed through the 2-wire serial interface. The serial data signal (SDA pin) is bi-directional for serial data transfer. The host uses SDA in conjunction with SCL to mark the start and end of serial protocol activation. The memories are organized as a series of 8-bit data words that can be addressed individually or sequentially. The 2-wire serial interface provides sequential or random access to the 8 bit parameters, addressed from 00h to the maximum address of the memory.

Recommended Host Board Power Supply Circuit

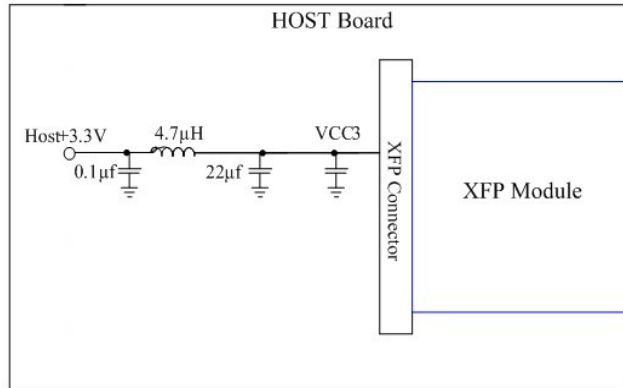

Recommended High-Speed Interface Circuit

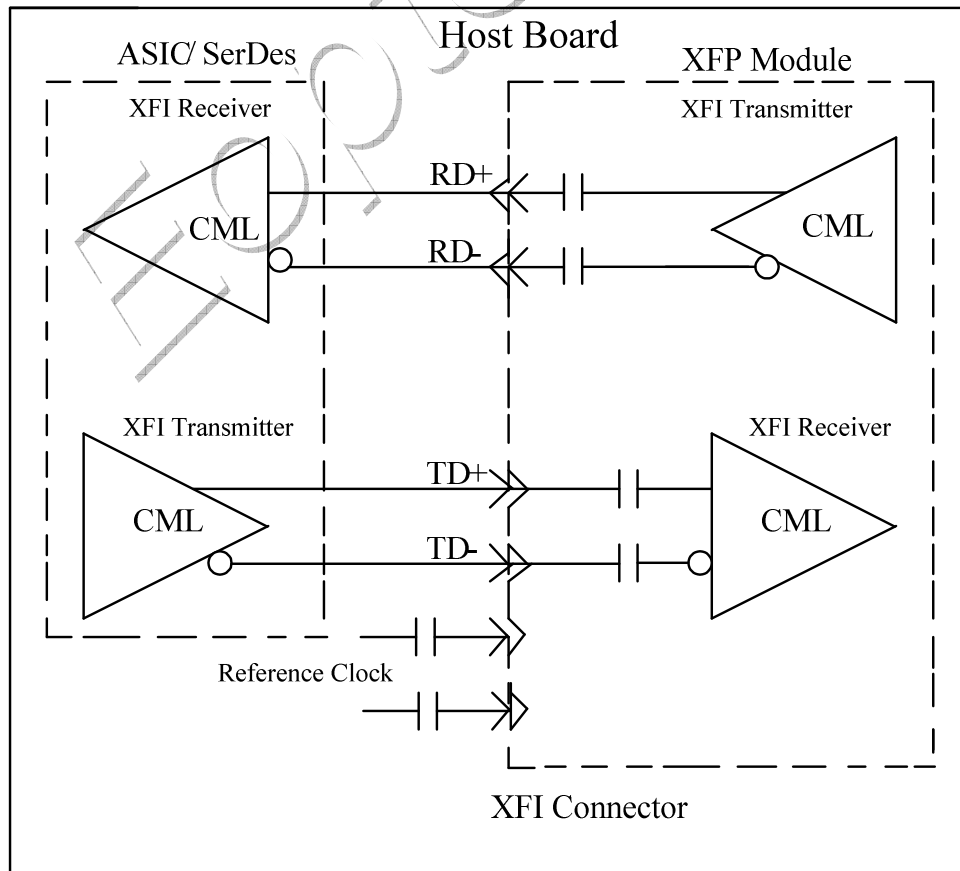

Mechanical Specifications

Eoptolink's XFP transceivers are compliant with the dimensions defined by the XFP Multi-Sourcing Agreement (MSA).

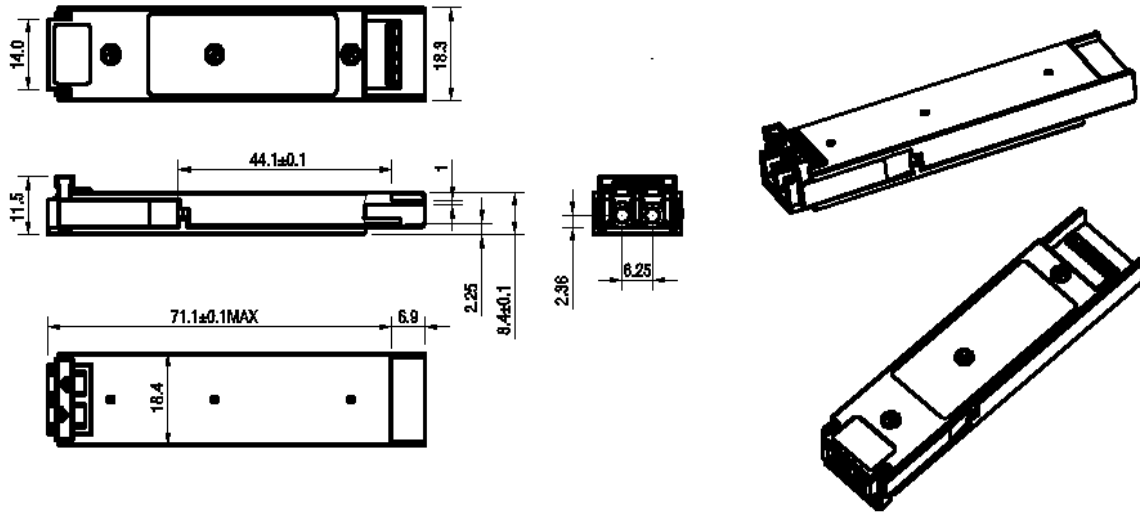

Eye Safety

This single-mode transceiver is a Class 1 laser product. It complies with IEC-60825 and FDA 21 CFR 1040.10 and 1040.11. The transceiver must be operated within the specified temperature and voltage limits. The optical ports of the module shall be terminated with an optical connector or with a dust plug.

Obtaining Document

You can visit our website:

<http://www.eoptolink.com>

Or contact Eoptolink Technology Inc., Ltd. listed at the end of the documentation to get the latest documents.

Revision History

| Revision | Initiated | Reviewed | Approved | Revision History | Release Date |
|----------|-----------|--------------|----------|---|---------------|
| V1.a | Kelly.Cao | Florence.Dai | | Released. | Jan 12, 2009 |
| V1.b | Kelly.Cao | | | Adding the complete CWDM wavelength. | June 24, 2009 |
| V1.c | Kelly.Cao | | | Revise the component and CWDM wavelength information. | Oct 10, 2009 |

| | | | | | |
|------|-----------|--|--|--|--------------|
| V1.d | Kelly.Cao | | | Add the application description. | Nov 6, 2009 |
| V1.e | Kelly.Cao | | | Add the CWDM wavelength and revise the laser type. | Dec 8, 2009 |
| V1.f | Kelly.Cao | | | Delete item7 in note2. | Dec 30, 2009 |
| V1.g | Kelly.Cao | | | Change the logo. | Jan 4, 2010 |

Notice:

Eoptolink reserves the right to make changes to or discontinue any optical link product or service identified in this publication, without notice, in order to improve design and/or performance. Applications that are described herein for any of the optical link products are for illustrative purposes only. Eoptolink makes no representation or warranty that such applications will be suitable for the specified use without further testing or modification.

Contact:

Add: Floor 5, Building 2, No. 21 Gaopeng Avenue, High-Tech District, CHENGDU, SICHUAN 610041 P.R. CHINA

Tel: (+86) 028-85122709 ext 816 & 809

Fax: (+86) 028-85121912

Postal: 610041

E-mail: sales@eoptolink.com

<http://www.eoptolink.com>