

EOLS-1626-B-X series

SFP Single-Mode for DWDM Application
Multi-rate from 100M to 2.67Gbps
Duplex SFP Transceiver
Digital Diagnostic Function
RoHS6 Compliant



Features

- ◆ Available in all C-Band Wavelengths on the 100GHz DWDM ITU Grid
- ◆ Data rates from 100Mbps to 2.67Gbps
- ◆ Temperature-Stabilized DWDM DFB Transmitter
- ◆ Duplex LC Connector
- ◆ Hot-Pluggable SFP Footprint
- ◆ Built-in Digital Diagnostic Functions as Specified in the SFF-8472 MSA
- ◆ Operating Case Temperature:
Extended: -5°C to 70°C

Applications

- ◆ SONET OC-48/SDH STM-16
- ◆ Amplified DWDM networks
- ◆ Ring topologies with fixed and reconfigurable OADMs
- ◆ Fast Ethernet, Giga Ethernet
- ◆ Fiber Channel

Ordering Information:

Part No.	Data Rate	Laser	Power budget ^{*(note2)}	Interface	Temperature
EOLS-1626-B-X ^{*(note1)}	0.1~2.67Gbps	DWDM DFB	30dB	LC	Extended

Note1: X refers to DWDM Wavelength range as ITU-T specified, please refer the following table for detailed center wavelength information.

Note2: Over the G.652 SMF, the dispersion tolerance is 2400ps/nm.

X- Channel refers to the following table:

Channel (X)	Part NO.	Frequency (THz)	Center Wavelength (nm)
15	EOLS-1626-B-15	191.5	1565.50

16	EOLS-1626-B-16	191.6	1564.68
17	EOLS-1626-B-17	191.7	1563.86
18	EOLS-1626-B-18	191.8	1563.05
19	EOLS-1626-B-19	191.9	1562.23
20	EOLS-1626-B-20	192.0	1561.42
21	EOLS-1626-B-21	192.1	1560.61
22	EOLS-1626-B-22	192.2	1559.79
23	EOLS-1626-B-23	192.3	1558.98
24	EOLS-1626-B-24	192.4	1558.17
25	EOLS-1626-B-25	192.5	1557.36
26	EOLS-1626-B-26	192.6	1556.55
27	EOLS-1626-B-27	192.7	1555.75
28	EOLS-1626-B-28	192.8	1554.94
29	EOLS-1626-B-29	192.9	1554.13
30	EOLS-1626-B-30	193.0	1553.33
31	EOLS-1626-B-31	193.1	1552.52
32	EOLS-1626-B-32	193.2	1551.72
33	EOLS-1626-B-33	193.3	1550.92
34	EOLS-1626-B-34	193.4	1550.12
35	EOLS-1626-B-35	193.5	1549.32
36	EOLS-1626-B-36	193.6	1548.51
37	EOLS-1626-B-37	193.7	1547.72
38	EOLS-1626-B-38	193.8	1546.92
39	EOLS-1626-B-39	193.9	1546.12
40	EOLS-1626-B-40	194.0	1545.32
41	EOLS-1626-B-41	194.1	1544.53
42	EOLS-1626-B-42	194.2	1543.73
43	EOLS-1626-B-43	194.3	1542.94
44	EOLS-1626-B-44	194.4	1542.14
45	EOLS-1626-B-45	194.5	1541.35
46	EOLS-1626-B-46	194.6	1540.56
47	EOLS-1626-B-47	194.7	1539.77
48	EOLS-1626-B-48	194.8	1538.98
49	EOLS-1626-B-49	194.9	1538.19
50	EOLS-1626-B-50	195.0	1537.40
51	EOLS-1626-B-51	195.1	1536.61
52	EOLS-1626-B-52	195.2	1535.82
53	EOLS-1626-B-53	195.3	1535.04
54	EOLS-1626-B-54	195.4	1534.25
55	EOLS-1626-B-55	195.5	1533.47
56	EOLS-1626-B-56	195.6	1532.68
57	EOLS-1626-B-57	195.7	1531.90

58	EOLS-1626-B-58	195.8	1531.12
59	EOLS-1626-B-59	195.9	1530.33
60	EOLS-1626-B-60	196.0	1529.55
61	EOLS-1626-B-61	196.1	1528.77

Regulatory Compliance

Feature	Standard	Performance
Electrostatic Discharge (ESD) to the Electrical Pins	MIL-STD-883G Method 3015.7	Class 1C (>1000V)
Electrostatic Discharge to the Enclosure	EN 55024:1998+A1+A2 IEC-61000-4-2 GR-1089-CORE	Compliant with standards
Electromagnetic Interference (EMI)	FCC Part 15 Class B EN55022: 2006 CISPR 22B: 2006 VCCI Class B	Compliant with standards Noise frequency range: 30MHz to 6GHz. Good system EMI design practice required to achieve Class B margins. System margins are dependent on customer host board and chassis design.
Immunity	EN 55024:1998+A1+A2 IEC 61000-4-3	Compliant with standards. 1KHz sine-wave, 80% AM, from 80MHz to 1GHz. No effect on transmitter/receiver performance is detectable between these limits.
Laser Eye Safety	FDA 21CFR 10X.10 and 10X.11 EN (IEC) 60825-1: 2007 EN (IEC) 60825-2: 2004+A1	CDRH compliant and Class I laser product. TüV Certificate No. 50135086
Component Recognition	UL and CUL EN60950-1: 2006	UL file E317337 TüV Certificate No. 50135086 (CB scheme)
RoHS6	2002/95/EC 4.1&4.2 2005/747/EC 5&7&13	Compliant with standards ^{*note3}

Note3: For update of the equipments and strict control of raw materials, EOPTOLINK has the ability to supply the customized products since Jan 1st, 2007, which meet the requirements of RoHS6 (Restrictions on use of certain Hazardous Substances) of European Union.

In light of item 5 in RoHS exemption list of RoHS Directive 2002/95/EC, Item 5: Lead in glass of cathode ray tubes, electronic components and fluorescent tubes.

In light of item 13 in RoHS exemption list of RoHS Directive 2005/747/EC, Item 13: Lead and cadmium in optical and filter glass. The three exemptions are being concerned for Eoptolink's transceivers, because Eoptolink's transceivers use glass, which may contain Pb, for components such as lenses, isolators, and other components.

Product Description

The EOLS-1626-B-X series single mode transceiver is small form factor pluggable module for duplex optical data communications. This module is designed for single mode fiber and operates at a nominal DWDM wavelength from 1528.77nm to 1563.86nm as specified by the ITU-T. It is designed to deploy in the DWDM networking equipment in metropolitan access and core networks.

It is with the SFP 20-pin connector to allow hot plug capability. The transmitter section uses a DWDM multiple quantum well DFB laser and is a class 1 laser compliant according to International Safety Standard IEC-60825. The receiver section uses a high sensitivity APD detector and a limiting post-amplifier IC.

The EOLS-1626-B-XD series are designed to be compliant with SFF-8472 Multi-Source Agreement (MSA).

Absolute Maximum Ratings

Parameter	Symbol	Min.	Max.	Unit
Storage Temperature	Ts	-40	+85	°C
Supply Voltage	Vcc	-0.5	3.6	V
Operating Relative Humidity		-	95	%

*Exceeding any one of these values may destroy the device immediately.

Recommended Operating Conditions

Parameter	Symbol	Min.	Typical	Max.	Unit
Operating Case Temperature	T _A EOLS-1626-B-X	-5		+70	°C
Power Supply Voltage	Vcc	3.15	3.3	3.45	V
Power Supply Current	Icc			380	mA
Date Rate		100M		2.67G	bps

Performance Specifications – Electrical

(T_{OP} = -5 to 70°C, V_{CC} = 3.15 to 3.45V)

Parameter	Symbol	Min.	Typ.	Max	Unit	Notes
Transmitter						
LVPECL Inputs(Differential)	Vin	400		2000	mVpp	AC coupled input ^{*(note3)}
Input Impedance (Differential)	Zin	85	100	115	ohm	Rin > 100 kohm @ DC
TX_Dis	Disable	2		Vcc+0.3	V	
	Enable	0		0.8		

TX_FAULT	Fault		2		V _{CC} +0.3	V	
	Normal		0		0.5		
Receiver							
CML Outputs (Differential)		V _{out}	400	800	1200	mV _{pp}	AC coupled output ^{*(note4)}
Output Impedance (Differential)		Z _{out}	85	100	115	ohm	
RX_LOS	LOS		2		V _{CC} +0.3	V	
	Normal		0		0.8	V	
MOD_DEF (0:2)		VoH	2.5			V	With Serial ID
		VoL	0		0.5	V	

Performance Specifications – Optical

(T_{OP} = -5 to 70°C, V_{CC} = 3.15 to 3.45V)

Parameter	Symbol	Min.	Typical	Max.	Unit
Data Rate		100M		2.67G	bps
Transmitter					
Center Wavelength	λ	1528		1564	nm
Spectral Width (-20dB)	$\Delta\lambda$			0.3	nm
Channel Spacing	Δf		100		GHz
Deviation From Central Frequency@EOL		-12		12	GHz
Side Mode Suppression Ratio	SMSR	30			dB
Average Output Power ^{*(note5)}	P _{out}	0		5	dBm
Average Launch Power (Tx: OFF)	P _{off}			-45	dBm
Extinction Ratio ^{*(note6)}	ER	8.2			dB
Rise/Fall Time(20%~80%)	tr/tf			160	ps
Output Optical Eye ^{*(note6)}	Compatible with ITU-T G.957 ^{*(note8)}				
TX_Disable Assert Time	t _{off}			10	us
P _{out} @TX Disable Asserted	P _{out}			-45	dBm
Optical Signal Noise Ratio @ 0.1nm	OSNR		40		dB
Relative Intensity Noise	RIN			-135	dB/Hz
Receiver					
Center Wavelength	λ	1528		1664	nm
Receiver Sensitivity ^{*(note7)}	P _{min}		-32	-30	dBm
Receiver Overload	P _{max}	-8			dBm
LOS De-Assert	LOSD			-31	dBm
LOS Assert	LOSA	-40			dBm
LOS Hysteresis ^{*(note9)}		0.5			dB

Note3: LVPECL logic, internally AC coupled and terminated to 100 differential loads.

Note4: CML logic, internally AC coupled.

Note5: Output is coupled into a 9/125 μ m single-mode fiber.

Note6: Filtered, measured with a PRBS 2²³-1 test pattern @2.488Gbps

Note7: Minimum average optical power measured at the BER less than 1E-12. The measure pattern is 2^{23} -1 NRZ PRBS and the ER of measure optical source is 9dB.

Note8: Eye Pattern Mask

Note9: LOS Hysteresis

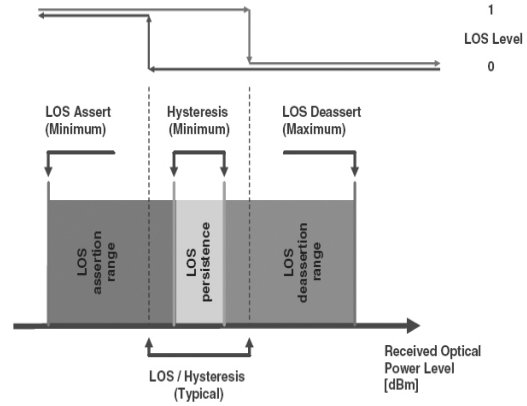
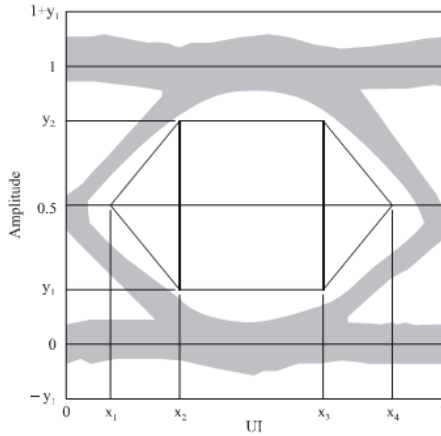

Functional Description of Transceiver

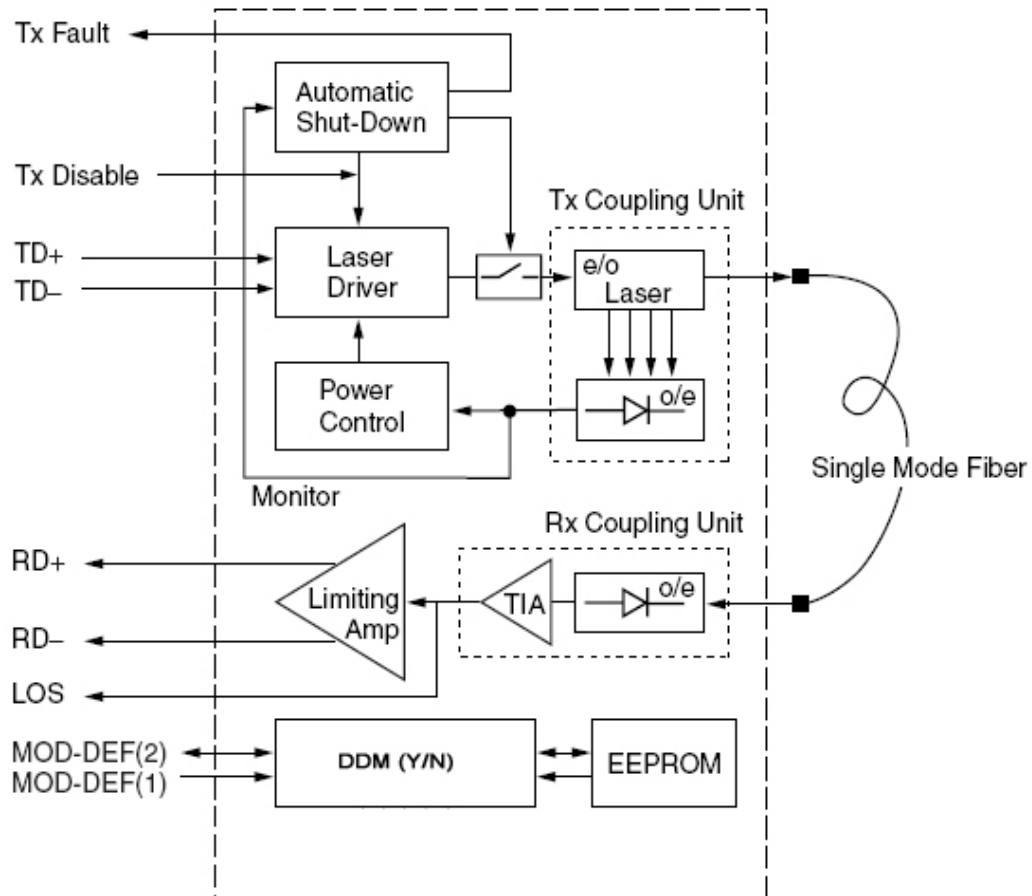

SFP Transceiver Electrical Pad Layout

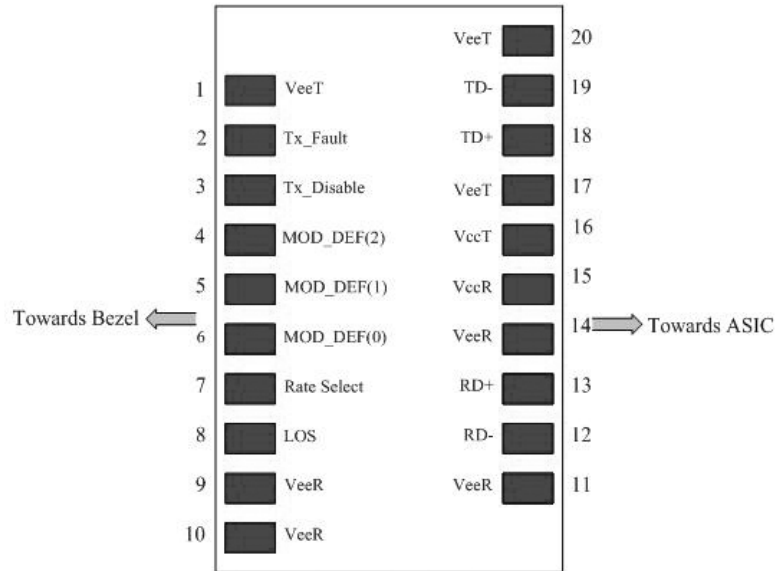
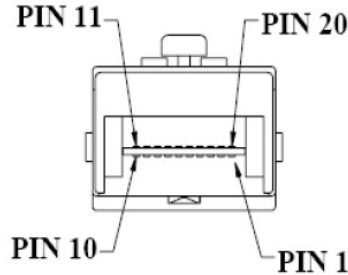

Pin Function Definition

Pin Num.	Name	Function	Plug Seq.	Notes
1	VeeT	Transmitter Ground	1	5)
2	TX Fault	Transmitter Fault Indication	3	1)
3	TX Disable	Transmitter Disable	3	2) Module disables on high or open
4	MOD-DEF2	Module Definition 2	3	3) Data line for Serial ID.
5	MOD-DEF1	Module Definition 1	3	3) Clock line for Serial ID.
6	MOD-DEF0	Module Definition 0	3	3) Grounded within the module.
7	Rate Select	Not Connect	3	Function not available
8	LOS	Loss of Signal	3	4)

9	VeeR	Receiver Ground	1	5)
10	VeeR	Receiver Ground	1	5)
11	VeeR	Receiver Ground	1	5)
12	RD-	Inv. Received Data Out	3	6)
13	RD+	Received Data Out	3	6)
14	VeeR	Receiver Ground	1	5)
15	VccR	Receiver Power	2	7) 3.3 ± 5%
16	VccT	Transmitter Power	2	7) 3.3 ± 5%
17	VeeT	Transmitter Ground	1	5)
18	TD+	Transmit Data In	3	8)
19	TD-	Inv. Transmit Data In	3	8)
20	VeeT	Transmitter Ground	1	5)

Notes:

1) TX Fault is an open collector/drain output, which should be pulled up with a 4.7K – 10KΩ resistor on the host board. Pull up voltage between 2.0V and VccT, R+0.3V. When high, output indicates a laser fault of some kind. Low indicates normal operation. In the low state, the output will be pulled to < 0.8V.

2) TX disable is an input that is used to shut down the transmitter optical output. It is pulled up within the module with a 4.7 – 10 KΩ resistor. Its states are:

Low (0 – 0.8V): Transmitter on

(>0.8, < 2.0V): Undefined

High (2.0 – 3.465V): Transmitter Disabled

Open: Transmitter Disabled

3) Modulation Absent, connected to VEET or VEER in the module.

4) LOS (Loss of Signal) is an open collector/drain output, which should be pulled up with a 4.7K – 10KΩ resistor. Pull up voltage between 2.0V and VccT, R+0.3V. When high, this output indicates the received optical power is below the worst-case receiver sensitivity (as defined by the standard in use). Low indicates normal operation. In the low state, the output will be pulled to < 0.8V.

5) VeeR and VeeT may be internally connected within the SFP module.

6) RD-/+: These are the differential receiver outputs. They are AC coupled 100Ω differential lines which should be terminated with 100Ω (differential) at the user SERDES. The AC coupling is done inside the module and is thus not required on the host board. The voltage swing on these lines will be between 400 and 2000mV differential (200 –1000mV single ended) when properly

terminated.

7) VccR and VccT are the receiver and transmitter power supplies. They are defined as 3.3V $\pm 5\%$ at the SFP connector pin. Maximum supply current is 300mA. Recommended host board power supply filtering is shown below. Inductors with DC resistance of less than 1 ohm should be used in order to maintain the required voltage at the SFP input pin with 3.3V supply voltage. When the recommended supply-filtering network is used, hot plugging of the SFP transceiver module will result in an inrush current of no more than 30mA greater than the steady state value. VccR and VccT may be internally connected within the SFP transceiver module.

8) TD-/+ : These are the differential transmitter inputs. They are AC-coupled, differential lines with 100 Ω differential termination inside the module. The AC coupling is done inside the module and is thus not required on the host board. The inputs will accept differential swings of 400 – 2000mV (200 – 1000mV single-ended).

EEPROM

The optical transceiver contains an EEPROM. It provides access to sophisticated identification information that describes the transceiver's capabilities, standard interfaces, manufacturer, and other information.

The serial interface uses the 2-wire serial CMOS EEPROM protocol defined for the ATMEL AT24C01A/02/04 family of components. When the serial protocol is activated, the host generates the serial clock signal (SCL, Mod Def 1). The positive edge clocks data into those segments of the EEPROM that are not writing protected within the SFP transceiver. The negative edge clocks data from the SFP transceiver. The serial data signal (SDA, Mod Def 2) is bi-directional for serial data transfer. The host uses SDA in conjunction with SCL to mark the start and end of serial protocol activation. The memories are organized as a series of 8-bit data words that can be addressed individually or sequentially.

The Module provides diagnostic information about the present operating conditions. The transceiver generates this diagnostic data by digitization of internal analog signals. Alarm/warning threshold data is written during device manufacture. TEC current monitoring, laser temperature monitoring, received power monitoring, transmitted power monitoring, bias current monitoring, supply voltage monitoring and transceiver temperature monitoring all are implemented. The diagnostic data are internal calibration and stored in memory locations 96 – 109 at wire serial bus address A2h. The transceiver memory map specific data field defines as following.

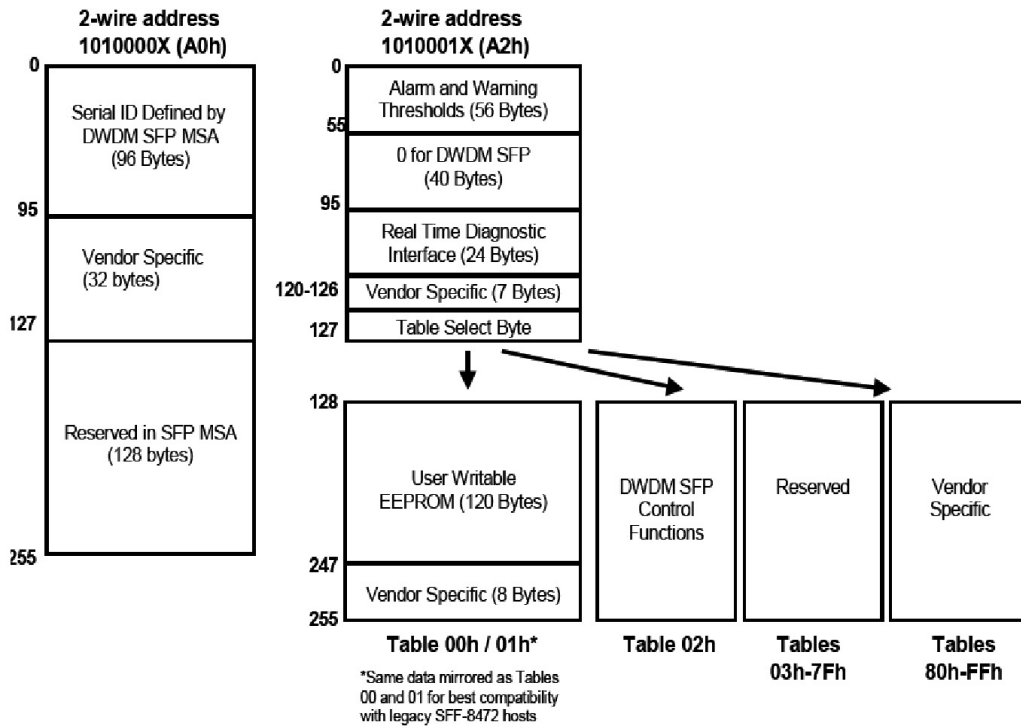

EEPROM Serial ID Memory Contents

Accessing Serial ID Memory uses the 2 wire address 1010000X (A0H). Memory Contents of Serial ID are shown in Table 1.

Table 1 Serial ID Memory Contents

Addr.	Size(bytes)	Name of field	Vaule(Hex)	Description
0	1	Identifier	0B	DWDM SFP
1	1	Ext. Identifier	24	DWDM,Power:1w~1.5w,Class of temp:[-5□-70□]
2	1	Connector	07	LC connector
3-10	8	Transceiver Codes	00	Reserved
			0C	OC-48 long reach , SONET LR-2
			00	-
			02	1000BASE-LX
			80	very long distance (V)
			10	Longwave laser(LL)
			01	Single mode
			05	100/200Mbytes/sec compliant
11	1	Encoding	05	SONET scrambled
12	1	BR, Nominal	19	2500Mb/s
13	1	Reserved	00	-

14	1	Length (9μm)km	78	Transceiver transmit distance
15	1	Length(9μm)100m	FF	
16	1	Length (50μm) 10m	00	
17	1	Length(62.5μm)10m	00	
18	1	Length (Copper)	00	Not compliant
19	1	Reserved	00	
20~35	16	Vendor Name	45 4F 50 54 4F 4C 49 4E 4B 20 49 4E 43 2E 20 20	EOPTOLIN INC.
36	1	Implemented Optional DWDM Features	00	-
37-39	3	Vendor OUI	00 00 00	-
40-55	16	Vendor PN	45 4F 4C 53 2D 31 36 34 38 2D 38 30 2D 58 20 20	“EOLS-1626-B-XXX” (ASCII)
56-59	4	Vendor Rev	31 2E 30 20	Revision 1.0(ASCII)
60-62	3	Wavelength	XX	Laser Wavelength
63	1	CC-BASE	XX	CC for Base ID fields implemented (addresses 0 to62)
64~65	2	Options	00	Reserved
			1A	1.TX_DISABLE is implemented and disables the serial output; 2.TX_FAULT signal implemented; 3.Loss of Signal implemented
66	1	BR, max	00	-
67	1	BR, max	00	-
68~83	16	Vendor SN	XX	Serial number of Transceiver (ASCII)
84~89	6	Date code	XX	The vendor's date code (ASCII)
90~91	2	Vendor specific lot	20 20	-

		code		
92	1	Diagnostic Monitoring Type	68	1. Digital diagnostic monitoring implemented 2. Internally Calibrated; 3. Received power measurement type is Average Power
93	1	Enhanced Options	F0	1. Optional Alarm/warning flags implemented for all monitored quantities 2. Optional Soft TX_DISABLE control and monitoring implemented 3. Optional Soft TX_FAULT monitoring Implemented 4. Optional Soft RX_LOS monitoring Implemented
94	1	SFF-8472 Compliance	01	Includes functionality described in Rev 9.3 of SFF-8472.
95	1	CC_EXT	XX	CC for the extended ID Fields (addresses 64 to 94) implemented.
96~127	32	Vendor Specific	XX	Read only memory
128-255	128	Reserved	Read only	

Note10: The “XX” byte should be filled in according to practical case. For more information, please refer to the related document of SFP Multi-Source Agreement (MSA).

Digital Diagnostic Monitoring Interface (2-Wire Address A2H)

Alarm and Warning Thresholds (2 Wire Address A2H)

Address	# Bytes	Name of Field	Real Value	Unit
00-01	2	Temp High Alarm	100	°C
02-03	2	Temp Low Alarm	-20	°C
04-05	2	Temp High Warning	95	°C
06-07	2	Temp Low Warning	-15	°C
08-09	2	Voltage High Alarm	3.6	V
10-11	2	Voltage Low Alarm	2.9	V
12-13	2	Voltage High Warning	3.5	V
14-15	2	Voltage Low Warning	3.0	V
16-17	2	Bias High Alarm	100	mA
18-19	2	Bias Low Alarm	2	mA
20-21	2	Bias High Warning	90	mA

22-23	2	Bias Low Warning	3	mA
24-25	2	TX Power High Alarm	6	dBm
26-27	2	TX Power Low Alarm	-1	dBm
28-29	2	TX Power High Warning	5	dBm
30-31	2	TX Power Low Warning	0	dBm
32-33	2	RX Power High Alarm	-7	dBm
34-35	2	RX Power Low Alarm	-31	dBm
36-37	2	RX Power High Warning	-8	dBm
38-39	2	RX Power Low Warning	-30	dBm
40-41	2	Laser Temp High Alarm	60	°C
42-43	2	Laser Temp Low Alarm	30	°C
44-45	2	Laser Temp High Warning	55	°C
46-47	2	Laser Temp Low Warning	35	°C
48-49	2	TEC Current High Alarm	300	Ma
50-51	2	TEC Current Low Alarm	-300	Ma
52-53	2	TEC Current High Warning	290	Ma
54-55	2	TEC Current Low Warning	-290	Ma

Calibration Constants (2 Wire Address A2H)

Data Address (dec)	Field size(Bytes)	Name Of Field	Description of Field
A/D Table for Alarm and Warning Thresholds			
56-94	39		Unused in DWDM devices. All Bytes Set to 0.
95	1	Checksum	Low order 8 bits of the sum of bytes 0-94
A/D Values and Status Bits			
96-109	8	A/D Values	Real-time A/D binary values of the following enhanced diagnostics: module temperature, supply voltage, laser bias current, transmits optical power; receive optical power, laser temperature and TEC current. These values are Internally calibrated absolute measurements. All diagnostic parameters implemented in these address locations have a corresponding high and low, alarm and warning thresholds

			assigned in address locations 00-55.
Optional Status/Control Bits			
110	1	Soft Control Signals	“Soft” control signals monitored over the 2-wire access port. Continuously updated real-time status of the following control signals: TX_FAULT, TX_DISABLE, Rate Select, and LOS. Last bit (LSB) indicates transceiver readiness to transmit data.
111	1	Reserved	Reserved
Reserved Optional Alarm and Warning Flag Bits			
112-117	5	Alarm & Warning Flags	Real time, single point bits indicating module parameters that are approaching or outside normal operating limits. Parameters monitored are: module temperature, supply voltage, laser bias current, transmit optical power, receive optical power, laser temperature and TEC current. The flags are internally calibrated thresholds with limits corresponding to levels detailed in addresses 00-39 above.
118-119	2	Warning Mask	Masking bits corresponding to Warning bits of bytes 116 and 117 respectively
Vendor Specific Memory Addresses			
120-126	8	Vendor Specific	Vendor specific data
Table Select Byte (2-wire Address A2h)			
127	1	Table Select	The byte value defines the Table location for subsequent reads and writes to bytes locations 128-255
User EEPROM			
128-247	120	User EEPROM	User writable EEPROM
248-255	8	Vendor Specific	Vendor specific control functions

Recommend Circuit Schematic

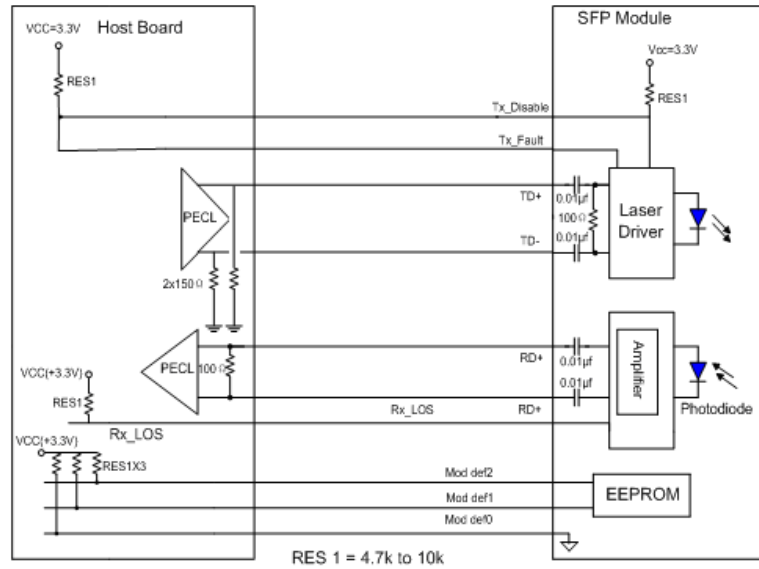

Mechanical Specifications

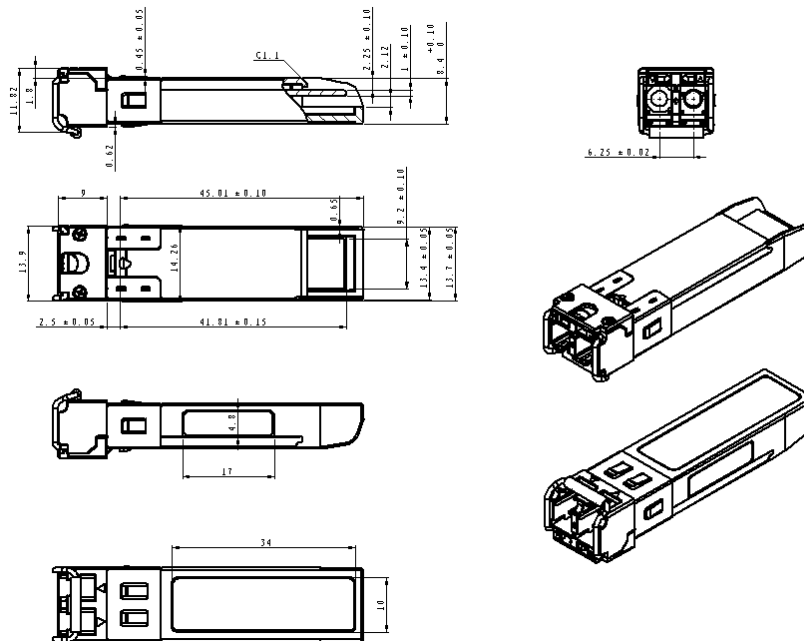

Class 1 Labels

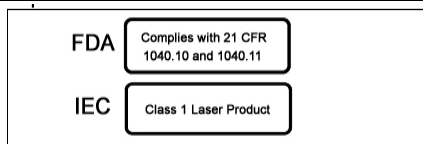

Laser Emission

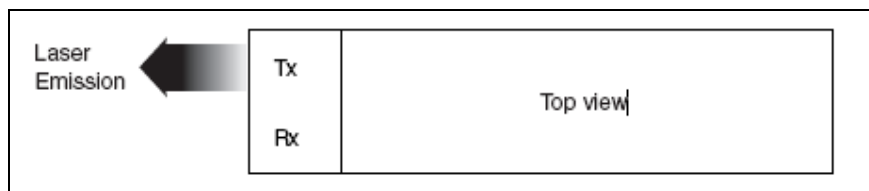

Obtaining Document

You can visit our website:

<http://www.eoptolink.com>

Or contact Eoptolink Technology Inc., Ltd. Listed at the end of the documentation to get the latest documents.

Revision History

Revision	Initiated	Reviewed	Approved	Revision History	Release Date
V1.a	Cathy.Chen	Kelly.Cao		Released.	Dec 3, 2009
V1.b	Cathy.Chen	Kelly.Cao		Complete A0h & add OSNR.	Dec 31, 2009
V1.c	Kelly.Cao			Correct the dispersion tolerance.	Jan 7, 2010
V1.d	Kelly.Cao			Correct the Tx monitor range.	Feb 21, 2010

Notice:

Eoptolink reserves the right to make changes to or discontinue any optical link product or service identified in this publication, without notice, in order to improve design and/or performance.

Applications that are described herein for any of the optical link products are for illustrative

purposes only. Eoptolink makes no representation or warranty that such applications will be suitable for the specified use without further testing or modification.

Contact:

Add: Floor 5, Building 2, No. 21 Gaopeng Avenue, High-Tech District, CHENGDU, SICHUAN
610041 P.R. CHINA

Tel: (+86) 028-85122709 ext 816 & 809

Fax: (+86) 028-85121912

Postal: 610041

E-mail: sales@eoptolink.com

<http://www.eoptolink.com>