

EOLP-1696-14XXX series

SFP+ Single-Mode for DWDM Application
Duplex SFP+ 50GHz Transceiver
Digital Diagnostic Function
RoHS6 Compliant



Features

- ◆ Available in all C-Band Wavelengths on the 50GHz DWDM ITU Grid
- ◆ Data rates from 9.95 to 11.1Gbps
- ◆ Temperature-Stabilized DWDM EML Transmitter
- ◆ Duplex LC Connector
- ◆ Hot-Pluggable SFP+ Footprint
- ◆ Built-in Digital Diagnostic Functions as Specified in the SFF-8431 MSA
- ◆ Operating Case Temperature: 0°C to 70°C

Applications

- ◆ 10GBASE-ER/EW 10G Ethernet
- ◆ 1200-SM-LL-L 10G Fiber Channel
- ◆ SDH STM S-64.2b

Ordering Information:

Part No.	Data Rate	Laser	Power budget ^{*(note2)}	DDMI	Temperature
EOLP-1696-14XXX ^{*(note1)}	9.953~11.1Gbps	DWDM EML	14dB	YES	0°C to 70°C

Note1: XXX refers to DWDM Wavelength channel as ITU-T specified, please refer the following table for detailed center wavelength information.

Note2: Over the G.652 SMF

X- Channel refers to the following table:

*Channel (X)	Part NO.	Frequency (THz)	Center Wavelength (nm)
200	EOLP-1696-14200	192.00	1561.42
205	EOLP-1696-14205	192.05	1561.01
210	EOLP-1696-14210	192.10	1560.61
215	EOLP-1696-14215	192.15	1560.20



DWDM SFP+ Series

220	EOLP-1696-14220	192.20	1559.79
225	EOLP-1696-14225	192.25	1559.39
230	EOLP-1696-14230	192.30	1558.98
235	EOLP-1696-14235	192.35	1558.58
240	EOLP-1696-14240	192.40	1558.17
245	EOLP-1696-14245	192.45	1557.77
250	EOLP-1696-14250	192.50	1557.36
255	EOLP-1696-14255	192.55	1556.96
260	EOLP-1696-14260	192.60	1556.55
265	EOLP-1696-14265	192.65	1556.15
270	EOLP-1696-14270	192.70	1555.75
275	EOLP-1696-14275	192.75	1555.34
280	EOLP-1696-14280	192.80	1554.94
285	EOLP-1696-14285	192.85	1554.54
290	EOLP-1696-14290	192.90	1554.13
295	EOLP-1696-14295	192.95	1553.73
300	EOLP-1696-14300	193.00	1553.33
305	EOLP-1696-14305	193.05	1552.93
310	EOLP-1696-14310	193.10	1552.52
315	EOLP-1696-14310	193.15	1552.12
320	EOLP-1696-14320	193.20	1551.72
325	EOLP-1696-14325	193.25	1551.32
330	EOLP-1696-14330	193.30	1550.92
335	EOLP-1696-14335	193.35	1550.52
340	EOLP-1696-14340	193.40	1550.12
345	EOLP-1696-14345	193.45	1549.72
350	EOLP-1696-14350	193.50	1549.32
355	EOLP-1696-14355	193.55	1548.91
360	EOLP-1696-14360	193.60	1548.51
365	EOLP-1696-14365	193.65	1548.11
370	EOLP-1696-14370	193.70	1547.72
375	EOLP-1696-14375	193.75	1547.32
380	EOLP-1696-14380	193.80	1546.92
385	EOLP-1696-14385	193.85	1546.52
390	EOLP-1696-14390	193.90	1546.12
395	EOLP-1696-14395	193.95	1545.72
400	EOLP-1696-14400	194.00	1545.32
405	EOLP-1696-14405	194.05	1544.92
410	EOLP-1696-14410	194.10	1544.53
415	EOLP-1696-14415	194.15	1544.13
420	EOLP-1696-14420	194.20	1543.73
425	EOLP-1696-14425	194.25	1543.33

430	EOLP-1696-14430	194.30	1542.94
435	EOLP-1696-14435	194.35	1542.54
440	EOLP-1696-14440	194.40	1542.14
445	EOLP-1696-14445	194.45	1541.75
450	EOLP-1696-14450	194.50	1541.35
455	EOLP-1696-14455	194.55	1540.95
460	EOLP-1696-14460	194.60	1540.56
465	EOLP-1696-14465	194.65	1540.16
470	EOLP-1696-14470	194.70	1539.77
475	EOLP-1696-14475	194.75	1539.37
480	EOLP-1696-14480	194.80	1538.98
485	EOLP-1696-14485	194.85	1538.58
490	EOLP-1696-14490	194.90	1538.19
495	EOLP-1696-14495	194.95	1537.79
500	EOLP-1696-14500	195.00	1537.40
505	EOLP-1696-14505	195.05	1537.00
510	EOLP-1696-14510	195.10	1536.61
515	EOLP-1696-14515	195.15	1536.22
520	EOLP-1696-14520	195.20	1535.82
525	EOLP-1696-14525	195.25	1535.43
530	EOLP-1696-14530	195.30	1535.04
535	EOLP-1696-14535	195.35	1534.64
540	EOLP-1696-14540	195.40	1534.25
545	EOLP-1696-14545	195.45	1533.86
550	EOLP-1696-14550	195.50	1533.47
555	EOLP-1696-14555	195.55	1533.07
560	EOLP-1696-14560	195.60	1532.68
565	EOLP-1696-14565	195.65	1532.29
570	EOLP-1696-14570	195.70	1531.90
575	EOLP-1696-14575	195.75	1531.51
580	EOLP-1696-14580	195.80	1531.12
585	EOLP-1696-14585	195.85	1530.72
590	EOLP-1696-14590	195.90	1530.33
595	EOLP-1696-14595	195.95	1529.94

*Please contact with EOPTOLINK for further information about channel whether or not it is available.

Regulatory Compliance

Feature	Standard	Performance
Electrostatic Discharge (ESD) to the Electrical Pins	MIL-STD-883G Method 3015.7	Class 1C (>1000V)

Electrostatic Discharge to the Enclosure	EN 55024:1998+A1+A2 IEC-61000-4-2 GR-1089-CORE	Compliant with standards
Electromagnetic Interference (EMI)	FCC Part 15 Class B EN55022: 2006 CISPR 22B: 2006 VCCI Class B	Compliant with standards Noise frequency range: 30MHz to 6GHz. Good system EMI design practice required to achieve Class B margins. System margins are dependent on customer host board and chassis design.
Immunity	EN 55024:1998+A1+A2 IEC 61000-4-3	Compliant with standards. 1KHz sine-wave, 80% AM, from 80MHz to 1GHz. No effect on transmitter/receiver performance is detectable between these limits.
Laser Eye Safety	FDA 21CFR 10X.10 and 10X.11 EN (IEC) 60825-1: 2007 EN (IEC) 60825-2: 2004+A1	CDRH compliant and Class I laser product. TüV Certificate No. 50135086
Component Recognition	UL and CUL EN60950-1: 2006	UL file E317337 TüV Certificate No. 50135086 (CB scheme)
RoHS6	2002/95/EC 4.1&4.2 2005/747/EC 5&7&13	Compliant with standards ^{*note3}

Note3: For update of the equipments and strict control of raw materials, EOPTOLINK has the ability to supply the customized products since Jan 1st, 2007, which meet the requirements of RoHS6 (Restrictions on use of certain Hazardous Substances) of European Union.

In light of item 5 in RoHS exemption list of RoHS Directive 2002/95/EC, Item 5: Lead in glass of cathode ray tubes, electronic components and fluorescent tubes.

In light of item 13 in RoHS exemption list of RoHS Directive 2005/747/EC, Item 13: Lead and cadmium in optical and filter glass. The three exemptions are being concerned for Eoptolink's transceivers, because Eoptolink's transceivers use glass, which may contain Pb, for components such as lenses, isolators, and other components.

Product Description

The EOLP-1696-14XXX series single mode transceiver is small form factor pluggable module for duplex optical data communications. This module is designed for single mode fiber and operates at a nominal DWDM wavelength from 1529.94nm to 1561.42nm as specified by the ITU-T. It is designed to deploy in the DWDM networking equipment in metropolitan access and core networks.

It is with the SFP+ 20-pin connector to allow hot plug capability. The transmitter section uses a DWDM EML laser and is a class 1 laser compliant according to International Safety Standard IEC-60825. The receiver section uses a PIN detector and a limiting post-amplifier IC.

The EOLP-1696-14XXXD series are designed to be compliant with SFP+ Multi-Source Agreement (MSA) Specification SFF-8431.

Absolute Maximum Ratings

Parameter	Symbol	Min.	Max.	Unit
Storage Temperature	Ts	-40	+85	°C
Supply Voltage	Vcc	-0.5	3.6	V
Operating Relative Humidity		-	95	%

*Exceeding any one of these values may destroy the device immediately.

Recommended Operating Conditions

Parameter	Symbol	Min.	Typical	Max.	Unit
Operating Case Temperature	T _A EOLP-1696-14XXX	0		+70	°C
Power Supply Voltage	Vcc	3.15	3.3	3.45	V
Power Supply Current	Icc			600	mA
Date Rate		9.953		11.1	Gbps

Performance Specifications – Electrical

(T_{OP} = 0 to 70°C, V_{CC} = 3.15 to 3.45V)

Parameter	Symbol	Min.	Typ.	Max	Unit	Notes
Transmitter						
CML Inputs(Differential)	Vin	250		1000	mVpp	AC coupled input*(note3)
Input Impedance (Differential)	Zin	85	100	115	ohm	Rin > 100 kohm @ DC
TX_Dis	Disable	2		Vcc+0.3	V	
	Enable	0		0.8		
TX_FAULT	Fault	2		Vcc+0.3	V	
	Normal	0		0.5		
Receiver						
CML Outputs (Differential)	Vout	350		700	mVpp	AC coupled output*(note3)
Output Impedance (Differential)	Zout	85	100	115	ohm	
RX_LOS	LOS	2		Vcc+0.3	V	
	Normal	0		0.8	V	
MOD_DEF (0:2)	VoH	2.5			V	With Serial ID
	VoL	0		0.5	V	

Performance Specifications – Optical

(T_{OP} = 0 to 70°C, V_{CC} = 3.15 to 3.45V)

Parameter	Symbol	Min.	Typ.	Max.	Unit
Data Rate		9.953		11.1	Gbps
Transmitter					
Frequency Range	-	192.00		195.95	THz
Channel Spacing	-	50			GHz
Wavelength Stability (BOL)	-	λ_C-6		λ_C+6	GHz
Wavelength Stability (EOL)	-	λ_C-10		λ_C+10	GHz
Side Mode Suppression Ratio	SMSR	35			dB
Average Output Power ^{*(note4)}	P _{out}	-2		3	dBm
Average Launch Power (Tx: OFF)	P _{off}			-30	dBm
Extinction Ratio	ER	8.2			dB
P _{out} @TX Disable Asserted	P _{out}			-45	dBm
Relative Intensity Noise	RIN			-128	dB/Hz
TX Jitter	TX _j	Per 802.3ae requirements			
Receiver					
Receiver Sensitivity ^{*(note5)}	P _{min}			-16	dBm
Receiver Overload	P _{max}	+0.5			dBm
Receiver Reflectance	R _{rx}				
LOS De-Assert	LOSD			-17	dBm
LOS Assert	LOSA	-28			dBm
LOS Hysteresis		1			dB

Note3: CML logic, internally AC coupled.

Note4: Output is coupled into a 9/125µm single-mode fiber.

Note5: Minimum average optical power measured at the BER less than 1E-12. The measure pattern is PRBS 2³¹-1.

SFP+ Transceiver Electrical Pad Layout

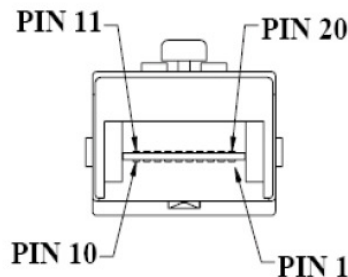

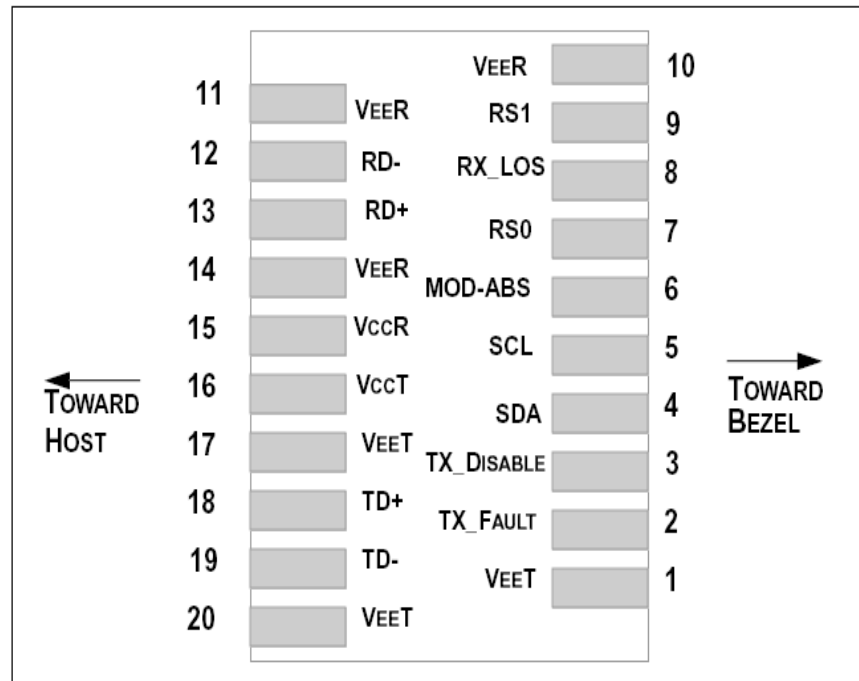

Pin Function Definition

Pin Num.	Name	FUNCTION	Plug Seq.	Notes
1	VeeT	Transmitter Ground	1	Note 5
2	TX Fault	Transmitter Fault Indication	3	Note 1
3	TX Disable	Transmitter Disable	3	Note 2, Module disables on high or open
4	SDA	Module Definition 2	3	Note 3, Data line for Serial ID.
5	SCL	Module Definition 1	3	Note 3, Clock line for Serial ID.
6	MOD-ABS	Module Definition 0	3	Note 3
7	RS0	RX Rate Select (LVTTTL).	3	This pin has an internal 30k pull down to ground. A signal on This pin will not affect module performance.
8	LOS	Loss of Signal	3	Note 4
9	RS1	TX Rate Select (LVTTTL).	1	This pin has an internal 30k pull down to ground. A signal on This pin will not affect module performance.
10	VeeR	Receiver Ground	1	Note 5
11	VeeR	Receiver Ground	1	Note 5

12	RD-	Inv. Received Data Out	3	Note 6
13	RD+	Received Data Out	3	Note 7
14	VeeR	Receiver Ground	1	Note 5
15	VccR	Receiver Power	2	3.3 ± 5%, Note 7
16	VccT	Transmitter Power	2	3.3 ± 5%, Note 7
17	VeeT	Transmitter Ground	1	Note 5
18	TD+	Transmit Data In	3	Note 8
19	TD-	Inv. Transmit Data In	3	Note 8
20	VeeT	Transmitter Ground	1	Note 5

Notes:

1) TX Fault is an open collector/drain output, which should be pulled up with a 4.7K – 10K Ω resistor on the host board. Pull up voltage between 2.0V and VccT, R+0.3V. When high, output indicates a laser fault of some kind. Low indicates normal operation. In the low state, the output will be pulled to < 0.8V.

2) TX disable is an input that is used to shut down the transmitter optical output. It is pulled up within the module with a 4.7 – 10 K Ω resistor. Its states are:

Low (0 – 0.8V): Transmitter on

(>0.8, < 2.0V): Undefined

High (2.0 – 3.465V): Transmitter Disabled

Open: Transmitter Disabled

3) Modulation Absent, connected to VEET or VEER in the module.

4) LOS (Loss of Signal) is an open collector/drain output, which should be pulled up with a 4.7K – 10K Ω resistor. Pull up voltage between 2.0V and VccT, R+0.3V. When high, this output indicates the received optical power is below the worst-case receiver sensitivity (as defined by the standard in use). Low indicates normal operation. In the low state, the output will be pulled to < 0.8V.

5) VeeR and VeeT may be internally connected within the SFP+ module.

6) RD-/+ : These are the differential receiver outputs. They are AC coupled 100 Ω differential lines which should be terminated with 100 Ω (differential) at the user SERDES. The AC coupling is done inside the module and is thus not required on the host board.

7) VccR and VccT are the receiver and transmitter power supplies. They are defined as 3.3V ±5% at the SFP+ connector pin. Maximum supply current is 300Ma. Inductors with DC resistance of less than 1 ohm should be used in order to maintain the required voltage at the SFP+ input pin with 3.3V supply voltage. When the recommended supply-filtering network is used, hot plugging of the SFP+ transceiver module will result in an inrush current of no more than 30Ma greater than the steady state value. VccR and VccT may be internally connected within the SFP+ transceiver

module.

8) TD-/+: These are the differential transmitter inputs. They are AC-coupled, differential lines with 100Ω differential termination inside the module. The AC coupling is done inside the module and is thus not required on the host board.

EEPROM

The optical transceiver contains an EEPROM. It provides access to sophisticated identification information that describes the transceiver’s capabilities, standard interfaces, manufacturer, and other information.

The serial interface uses the 2-wire serial CMOS EEPROM protocol. When the serial protocol is activated, the host generates the serial clock signal (SCL, Mod Def 1). The positive edge clocks data into those segments of the EEPROM that are not writing protected within the SFP+ transceiver. The negative edge clocks data from the SFP+ transceiver. The serial data signal (SDA, Mod Def 2) is bi-directional for serial data transfer. The host uses SDA in conjunction with SCL to mark the start and end of serial protocol activation. The memories are organized as a series of 8-bit data words that can be addressed individually or sequentially.

The module provides diagnostic information about the present operating conditions. The transceiver generates this diagnostic data by digitization of internal analog signals. Alarm/warning threshold data is written during device manufacture. TEC current monitoring, laser temperature monitoring, received power monitoring, transmitted power monitoring, bias current monitoring, supply voltage monitoring and transceiver temperature monitoring all are implemented. The diagnostic data are internal calibration and stored in memory locations 96 – 109 at wire serial bus address A2h. The transceiver memory map specific data field defines as following.

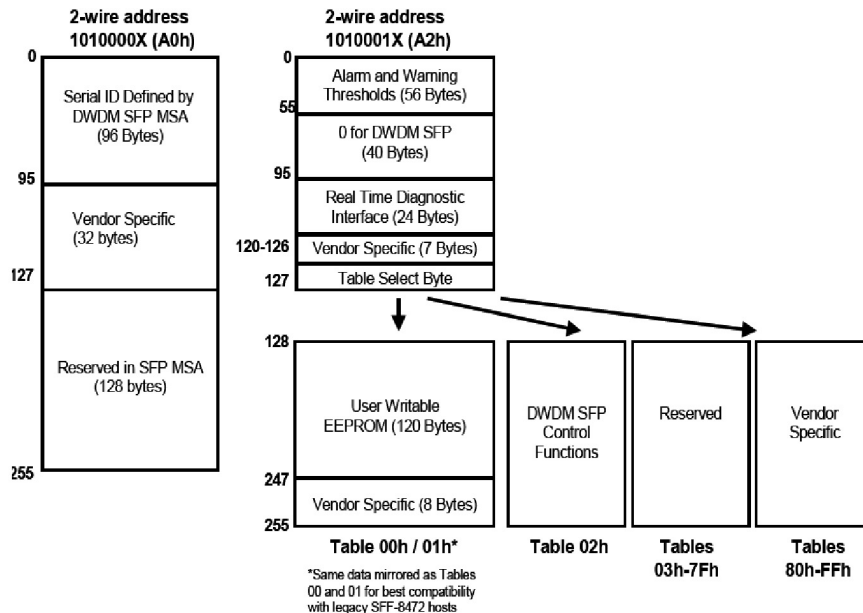

Recommend Circuit Schematic

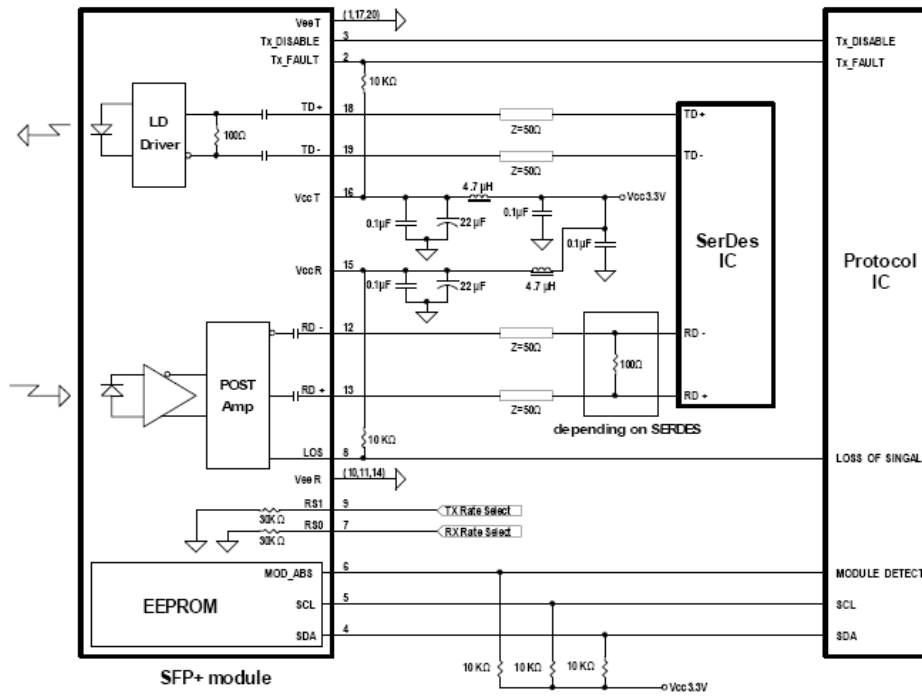

Mechanical Specifications

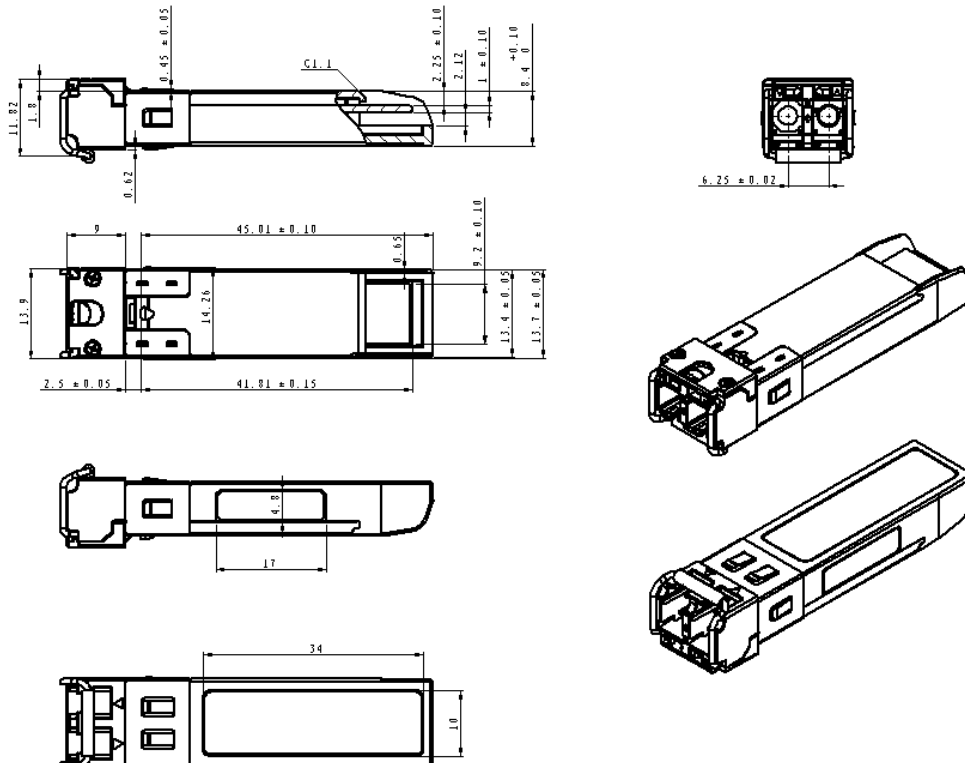

Class 1 Labels

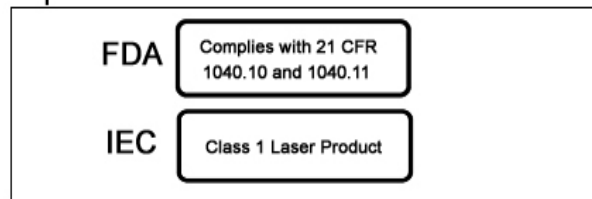

Laser Emission



Obtaining Document

You can visit our website: <http://www.eoptolink.com>

Or contact Eoptolink Technology Inc., Ltd. listed at the end of the documentation to get the latest documents.

Revision History

Revision	Initiated	Reviewed	Approved	DCN	Release Date
V2.a	Kelly.Cao			Add frequency deviation and released.	May 23, 2011

Notice:

Eoptolink reserves the right to make changes to or discontinue any optical link product or service identified in this publication, without notice, in order to improve design and/or performance. Applications that are described herein for any of the optical link products are for illustrative purposes only. Eoptolink makes no representation or warranty that such applications will be suitable for the specified use without further testing or modification.

Contact:

Add: Floor 5, Building 2, No. 21 Gaopeng Avenue, High-Tech District, CHENGDU, SICHUAN
610041 P.R. CHINA

Tel: (+86) 028-85122709 ext 816 & 809

Fax: (+86) 028-85121912

Postal: 610041

E-mail: sales@eoptolink.com

<http://www.eoptolink.com>