

EOLG-1312-X Series

**Single-Mode 1310nm Gigabit Interface Converter
Duplex GBIC Transceiver
RoHS6 Compliant**

Features

- ◆ Operating Data Rate up to 1.25Gbps
- ◆ 1310nm FP Transmitter
- ◆ 10km links with 9/125um SMF
20km links with 9/125um SMF
30km links with 9/125um SMF
- ◆ 3.3/5V Power Supply and TTL Logic Interface
- ◆ Hot Pluggable with Duplex SC Connector Interface
- ◆ Class 1 FDA and IEC60825-1 Laser Safety Compliant
- ◆ Operating Case Temperature
Standard: 0°C~+70°C
Industrial: -40°C~+85°C
- ◆ Compliant with GBIC Specification Rev. 5.5
- ◆ Compliant with IEEE 802.3z Gigabit Ethernet
1000BASE-LX



Applications

- ◆ GBE Links
- ◆ Fiber Channel Links

Ordering Information

Part No.	Data Rate	Fiber	Distance	Interface	Temperature
EOLG-1312-10*(note1)	1.25Gbps	SMF	10km	SC	Standard
EOLG-1312-10I	1.25Gbps	SMF	10km	SC	Industrial
EOLG-1312-20*(note1)	1.25Gbps	SMF	20km	SC	Standard
EOLG-1312-20I	1.25Gbps	SMF	20km	SC	Industrial
EOLG-1312-30*(note1)	1.25Gbps	SMF	30km	SC	Standard
EOLG-1312-30I	1.25Gbps	SMF	30km	SC	Industrial

Note1: Standard version

Regulatory Compliance

Feature	Standard	Performance
Electrostatic Discharge (ESD) to the Electrical Pins	MIL-STD-883G Method 3015.7	Class 1C (>1000 V)
Electrostatic Discharge to the enclosure	EN 55024:1998+A1+A2 IEC-61000-4-2 GR-1089-CORE	Compliant with standards
Electromagnetic Interference (EMI)	FCC Part 15 Class B EN55022:2006 CISPR 22B :2006 VCCI Class B	Compliant with standards Noise frequency range: 30MHz to 6GHz. Good system EMI design practice required to achieve Class B margins. System margins are dependent on customer host board and chassis design.
Immunity	EN 55024:1998+A1+A2 IEC 61000-4-3	Compliant with standards. 1KHz sine-wave, 80% AM, from 80MHz to 1GHz. No effect on transmitter/receiver performance is detectable between these limits.
Laser Eye Safety	FDA 21CFR 1040.10 and 1040.11 EN (IEC) 60825-1:2007 EN (IEC) 60825-2:2004+A1	CDRH compliant and Class I laser product. TüV Certificate No. 50135086
Component Recognition	UL and CUL EN60950-1:2006	UL file E317337 TüV Certificate No. 50135086 (CB scheme)
RoHS6	2002/95/EC 4.1&4.2 2005/747/EC 5&7&13	Compliant with standards ^{*note3}

Note3: For update of the equipments and strict control of raw materials, EOPTOLINK has the ability to supply the customized products since Jan 1st, 2007, which meet the requirements of RoHS6 (Restrictions on use of certain Hazardous Substances) of European Union.

In light of item 5 in RoHS exemption list of RoHS Directive 2002/95/EC, Item 5: Lead in glass of cathode ray tubes, electronic components and fluorescent tubes.

In light of item 13 in RoHS exemption list of RoHS Directive 2005/747/EC, Item 13: Lead and cadmium in optical and filter glass. The three exemptions are being concerned for Eoptolink's transceivers, because Eoptolink's transceivers use glass, which may contain Pb, for components such as lenses, windows, isolators, and other electronic components.

Product Description

The EOLG-1312-30 series optical transceivers meet the Gigabit Interface Converter (GBIC)

specification Rev.5.5. It satisfies the optical interface specifications defined in IEEE 802.3z Drift 5.0 for Gigabit Ethernet. This module is designed for single-mode fiber and operates at a nominal wavelength of 1310nm.

The transmitter section uses a FP laser and is a class 1 laser compliant according to International Safety Standard IEC-60825. The receiver section uses an integrated InGaAs detector preamplifier (IDP) mounted in an optical header and a limiting post-amplifier IC. A PECL input / output logic interface is used. TTL RX-LOS output simplifies interface to external circuitry. A 20-pin SCA-2 host connector is used to connect the converter to the host system.

Absolute Maximum Ratings

Parameter	Symbol	Min.	Max.	Unit
Storage Temperature	Ts	-40	+85	°C
Supply Voltage	Vcc3	-0.5	3.6	V
	Vcc5	-0.5	6.0	
Operating Relative Humidity		-	95	%

*Exceeding any one of these values may destroy the device immediately.

Recommended Operating Conditions

Parameter	Symbol	Min.	Typical	Max.	Unit	
Operating Case Temperature	T _A	EOLG-1312-X	0		+70	°C
		EOLG-1312-XI	-40		+85	
Power Supply Voltage	Vcc		3.15	3.3	3.45	V
			4.5	5	5.5	
Power Supply Current	Icc			300	mA	
Data Rate	GBE		1.25		Gbps	
	FC		1.063			

Performance Specifications - Electrical

Parameter	Symbol	Min.	Typ.	Max	Unit	Notes
Transmitter						
LVPECL Inputs(Differential)	Vin	400		2000	mVpp	AC coupled input*(note5)
Input Impedance (Differential)	Zin	85	100	115	ohm	Rin > 100 kohm @ DC
TX_Dis	Disable	2		Vcc+0.3	V	
	Enable	0		0.8		
TX_FAULT	Fault	2		Vcc+0.3	V	
	Normal	0		0.8		
Receiver						
LVPECL Outputs (Differential)	Vout	370		2000	mVpp	AC coupled output*(note5)
Output Impedance	Zout	85	100	115	ohm	

(Differential)						
RX_LOS	LOS		2		V _{CC} +0.3	V
	Normal		0		0.8	V
MOD_DEF (0:2)		VoH	2.5			V
		VoL	0		0.5	V

With Serial ID

Optical and Electrical Characteristics

(1310nm FP and PIN, 10km)

Parameter	Symbol	Min.	Typical	Max.	Unit
9μm Core Diameter SMF			10		km
Data Rate			1.063/1.25		Gbps
Transmitter					
Center Wavelength	λ_C	1260	1310	1360	nm
Spectral Width (RMS)	$\Delta\lambda$			4	nm
Average Output Power ^{*(note3)}	P _{out}	-9		-3	dBm
Extinction Ratio ^{*(note4)}	ER	9			dB
Rise/Fall Time(20%~80%)	tr/tf			260	ns
Total Jitter	TJ			56.5	ps
Output Optical Eye ^{*(note4)}	IEEE 802.3z and ANSI Fibre Channel compatible ^{*(note7)}				
TX_Disable Assert Time	t _{off}			10	us
P _{out} @TX Disable Asserted	P _{out}			-45	dBm
Receiver					
Center Wavelength	λ_C	1100		1600	nm
Sensitivity ^{*(note6)}	P _{min}			-20	dBm
Receiver Overload	P _{max}	-3			dBm
LOS De-Assert	LOSD			-21	dBm
LOS Assert	LOSA	-42			dBm
LOS Hysteresis ^{*(note8)}		0.5			dB

(1310nm FP and PIN, 20km)

Parameter	Symbol	Min.	Typical	Max.	Unit
9μm Core Diameter SMF			20		km
Data Rate			1.063/1.25		Gbps
Transmitter					
Center Wavelength	λ_C	1260	1310	1360	nm
Spectral Width (RMS)	$\Delta\lambda$			4	nm
Average Output Power ^{*(note3)}	P _{out}	-6		-1	dBm
Extinction Ratio ^{*(note4)}	ER	9			dB
Rise/Fall Time(20%~80%)	tr/tf			260	ns
Total Jitter	TJ			56.5	ps
Output Optical Eye ^{*(note4)}	IEEE 802.3z and ANSI Fibre Channel compatible ^{*(note7)}				
TX_Disable Assert Time	t _{off}			10	us
P _{out} @TX Disable Asserted	P _{out}			-45	dBm

Receiver					
Center Wavelength	λ_C	1100		1600	nm
Sensitivity ^{*(note6)}	P _{min}			-22	dBm
Receiver Overload	P _{max}	-3			dBm
LOS De-Assert	LOSD			-23	dBm
LOS Assert	LOSA	-42			dBm
LOS Hysteresis ^{*(note8)}		0.5			dB

(1310nm FP and PIN, 30km)

Parameter	Symbol	Min.	Typical	Max.	Unit
9 μ m Core Diameter SMF			30		km
Data Rate			1.063/1.25		Gbps
Transmitter					
Center Wavelength	λ_C	1260	1310	1360	nm
Spectral Width (RMS)	$\Delta\lambda$			4	nm
Average Output Power ^{*(note3)}	P _{out}	-5		0	dBm
Extinction Ratio ^{*(note4)}	ER	9			dB
Rise/Fall Time(20%~80%)	tr/tf			260	ns
Total Jitter	TJ			56.5	ps
Output Optical Eye ^{*(note4)}	IEEE 802.3z and ANSI Fibre Channel compatible ^{*(note7)}				
TX_Disable Assert Time	t _{off}			10	us
P _{out} @TX Disable Asserted	P _{out}			-45	dBm
Receiver					
Center Wavelength	λ_C	1100		1600	nm
Sensitivity ^{*(note6)}	P _{min}			-24	dBm
Receiver Overload	P _{max}	-3			dBm
LOS De-Assert	LOSD			-25	dBm
LOS Assert	LOSA	-42			dBm
LOS Hysteresis ^{*(note8)}		0.5			dB

Note3: Output is coupled into a 9/125 μ m single-mode fiber.

Note4: Filtered, measured with a PRBS 2⁷-1 test pattern @1.25Gbps

Note5: LVPECL logic, internally AC coupled.

Note6: Minimum average optical power measured at BER less than 1E-12, with a 2⁷-1 PRBS and ER=9 dB.

Note7: Eye Pattern Mask

Note8: LOS Hysteresis

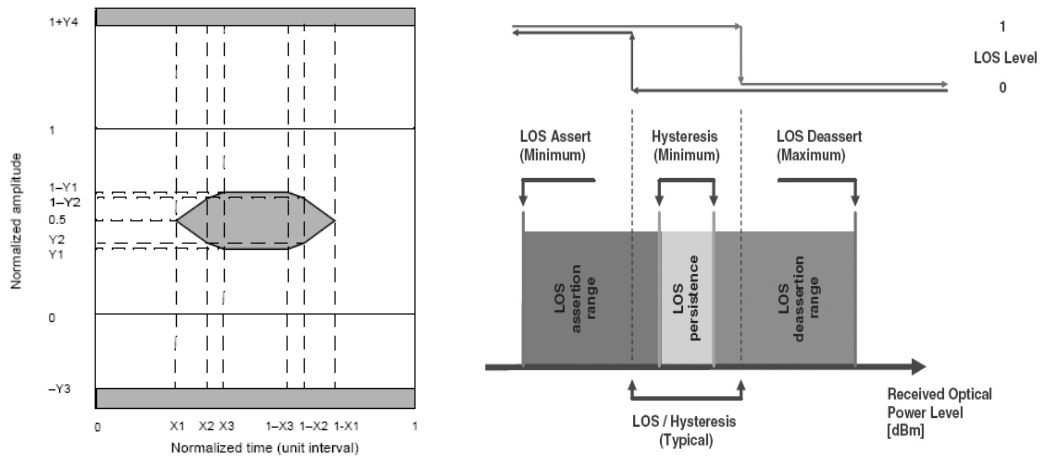

Functional Description of Transceiver

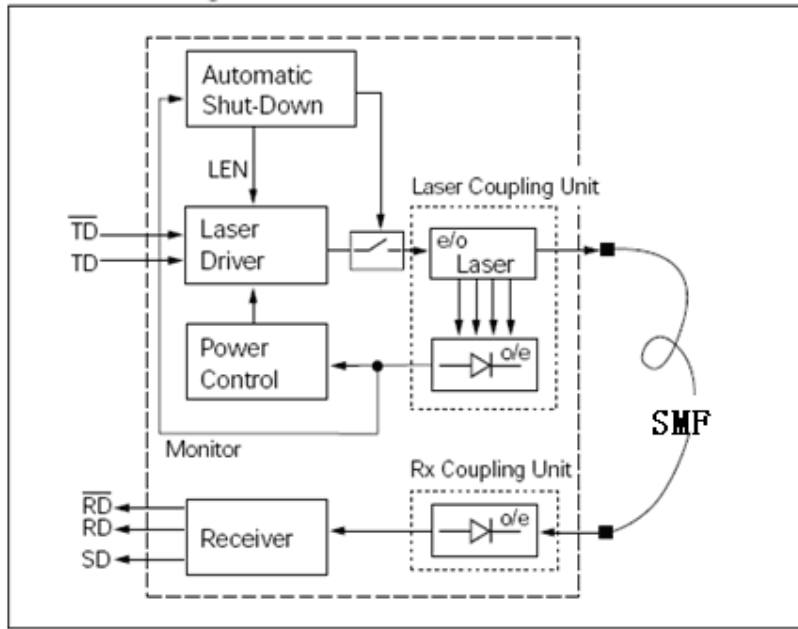

GBIC Transceiver Electrical Pad Layout

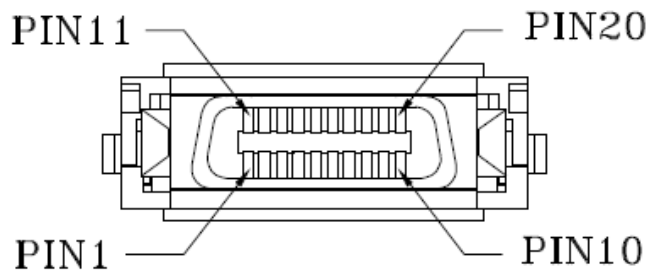

Pin Name	Pin#	Sequence
RX_LOS	1	2
RGND	2	2
RGND	3	2
MOD_DEF(0)	4	2
MOD_DEF(1)	5	2
MOD_DEF(2)	6	2
TX_DISABLE	7	2
TGND	8	2
TGND	9	2
TX_FAULT	10	2
RGND	11	1
-RX_DAT	12	1
+RX_DAT	13	1
RGND	14	1
VDDR	15	2
VDDT	16	2
TGND	17	1
+TX_DAT	18	1
-TX_DAT	19	1
TGND	20	1

Pin Function Definitions

Pin Name	Pin #	Name/Function	Signal Specification
Receiver Signals			
RGND	2,3,11, 14	Receiver Ground(may be connected with TGND in GBIC)	Ground, to GBIC
VDDR	15	Receiver +5 volt (may be connected with VDDT in GBIC)	Power, to GBIC
-RX_DAT	12	Receive Data, Differential PECL	High speed serial, from GBIC
+RX_DAT	13	Receive Data, Differential PECL	High speed serial, from GBIC
RX_LOS	1	Receiver Loss of Signal, logic high, open collector compatible,4.7 K to 10 K Ohm pullup to VDDT on host	Low speed, from GBIC
Transmitter Signals			
TGND	8,9,17, 20	Transmitter Ground (may be connected with RGND internally)	Ground, to GBIC
VDDT	16	Transmitter +5 volt (may be connected with VDDR in GBIC)	Power, to GBIC

+TX_DAT	18	Transmit Data, Differential PECL	High speed serial, to GBIC
-TX_DAT	19	Transmit Data, Differential PECL	High speed serial, to GBIC
TX_DISABLE	7	Transmitter Disable, logic high, open collector compatible, 4.7K to 10 K Ohm pullup to VDDT on GBIC	Low speed, to GBIC
TX_FAULT	10	Transmitter Fault, logic high, open collector compatible, 4.7 Kto 10 K Ohm pullup to VDDT on host	Low speed, from GBIC
Control Signals			
MOD_DEF(0)	4	GBIC module definition and presence, bit 0, 4.7 K to 10 K Ohm pullup to VDDT on host	Low speed, from GBIC
MOD_DEF(1)	5	GBIC module definition and presence, bit 1, 4.7 K to 10 K Ohm pullup to VDDT on host	Low speed, from GBIC
MOD_DEF(2)	6	GBIC module definition and presence, bit 2, 4.7 K to 10 K Ohm pullup to VDDT on host	Low speed, from GBIC

EEPROM

The serial interface uses the 2-wire serial CMOS EEPROM protocol defined for the ATMEL AT24C02/04 family of components. When the serial protocol is activated, the host generates the serial clock signal (SCL). The positive edge clocks data into those segments of the EEPROM that are not writing protected within the GBIC transceiver. The negative edge clocks data from the GBIC transceiver. The serial data signal (SDA) is bi-directional for serial data transfer. The host uses SDA in conjunction with SCL to mark the start and end of serial protocol activation. The memories are organized as a series of 8-bit data words that can be addressed individually or sequentially.

EEPROM Serial ID Memory Contents

Accessing Serial ID Memory uses the 2 wire address 1010000X(A0H). Memory Contents of Serial ID are shown in Table 1.

Table 1 Serial ID Memory Contents

Addr.	Size (Bytes)	Name of Field	Hex	Description
BASE ID FIELDS				
0	1	Identifier	01	GBIC
1	1	Ext. Identifier	04	GBIC function is defined by serial ID only
2	1	Connector	01	SC Connector
3-10	8	Transceiver	00 00 00 22 10 10 01	Transmitter Code

			01	
11	1	Encoding	01	8B10B
12	1	BR, Nominal	0D	1.25Gbps
13	1	Reserved	00	
14	1	Length (9μm)km	0A/14/1E	Transceiver transmit distance
15	1	Length(9μm)100m	64/C8/FF	
16	1	Length (50μm) 10m	00	
17	1	Length(62.5μm)10m	00	
18	1	Length (Copper)	00	Not compliant
19	1	Reserved	00	
20-35	16	Vendor name	XX XX XX XX XX XX XX XX ^(note9) 20 20 20 20 20 20 20 20	Vendor name (ASCII)
36	1	Reserved	00	
37-39	3	Vendor OUI	XX XX XX ^(note9)	
40-55	16	Vendor PN		Transceiver part number
56-59	4	Vendor rev	XX XX XX XX ^(note9)	
60-61	2	Wavelength	05 1E	1310nm
62	1	Reserved	00	
63	1	CC_BASE	Check Sum (Variable)	Check code for Base ID Fields
EXTENDED ID FIELDS				
64-65	2	Options	00 1A	TX_DISABLE, TX_FAULT and Loss of Signal implemented.
66	1	BR, max	00	
67	1	BR, min	00	
68-83	16	Vendor SN	XX XX XX XX XX XX XX XX 20 20 20 20 20 20 20 20 ^(note9)	Serial Number of transceiver (ASCII). For example "B000822".
84-91	8	Date code	XX XX XX XX XX XX XX XX ^(note9)	Manufactory date code. For example "080405".
92	1	Diagnostic Monitoring Type	00	Digital diagnostic monitoring implemented
93	1	Enhanced Options	00	Optional flags
94	1	SFF_8472 Compliance	00	01 for diagnostics (Rev9.3 SFF-8472).
95	1	CC_EXT	Check Sum (Variable)	Check sum for Extended ID Field.
VENDOR SPECIFIC ID FIELDS				
96-127	32	Vendor Specific	Read only	Depends on customer

				information
128-255	128	Reserved	Read only	

Note9: The "XX" byte should be filled in according to practical case. For more information, please refer to the related document of GBIC Multi-Source Agreement (MSA).

Eoptolink

Recommend Circuit Schematic

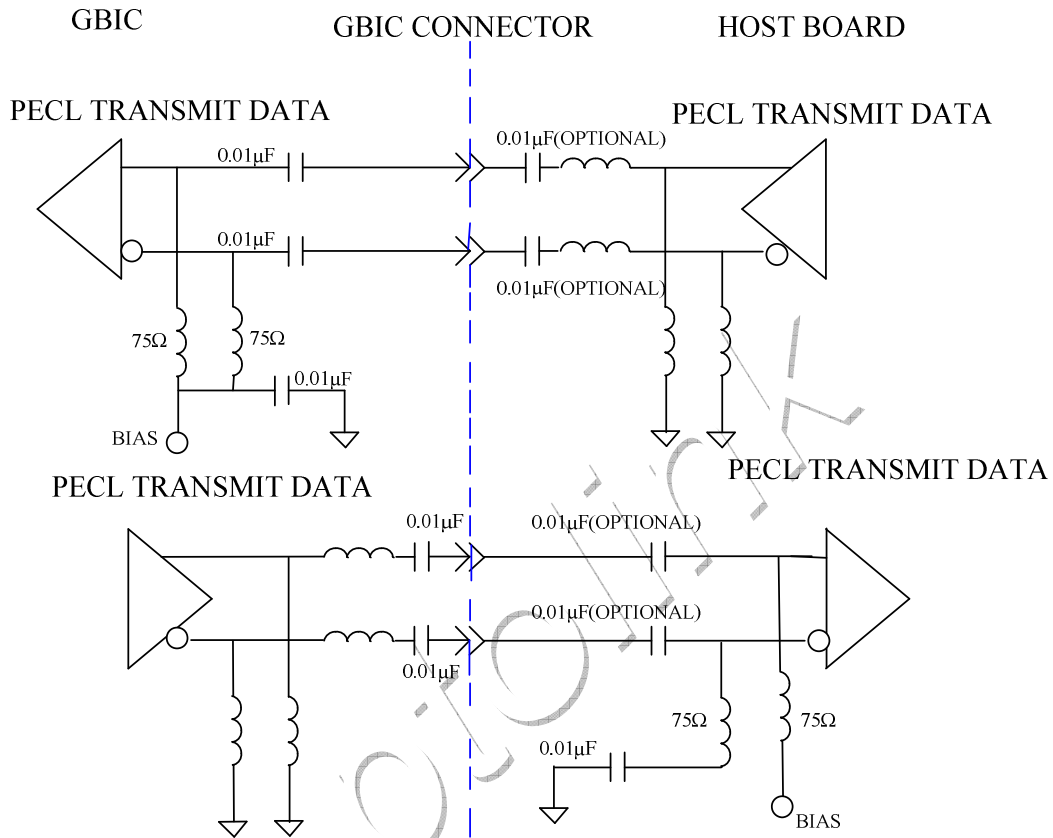

Mechanical Specifications

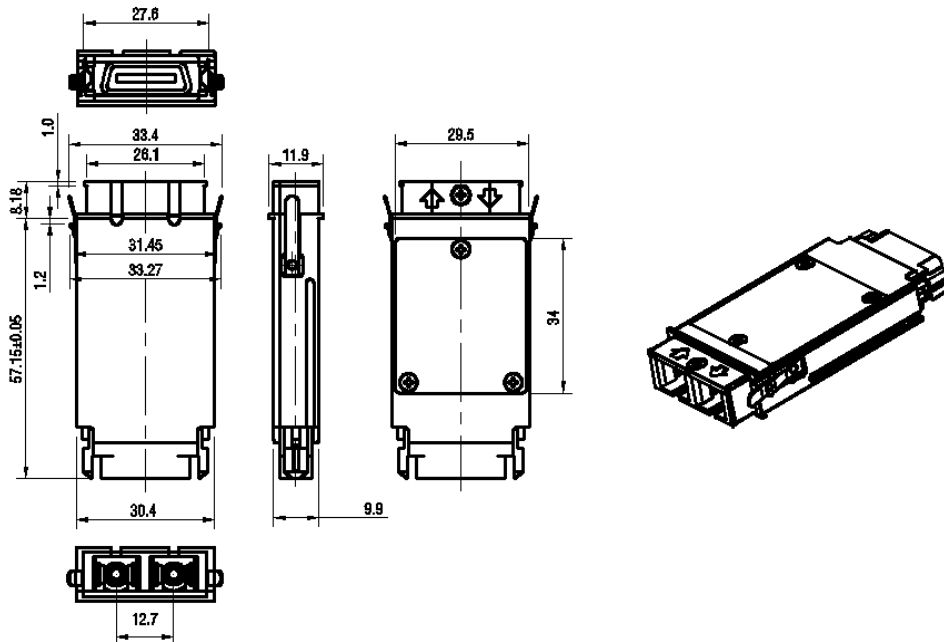

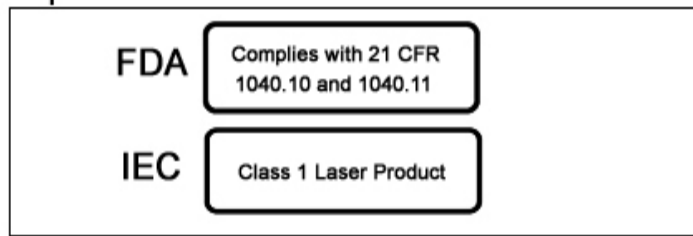
Class 1 Labels

Laser Emission Data

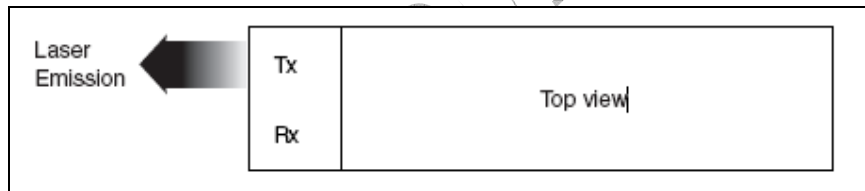
Wavelength	1310nm
Total output power (as defined by FDA: 7mm aperture at 20cm distance)	<0.076mW
Total output power (as defined by IEC: 7mm aperture at 10cm distance)	<0.778mW
Beam divergence	12°

Laser Emission

Obtaining Document

You can visit our website:

<http://www.eoptolink.com>

Or contact Eoptolink Technology Inc., Ltd. listed at the end of the documentation to get the latest documents.

Revision History

Revision	Initiated	Reviewed	Approved	DCN	Release Date
V4.a	Cathy	Kelly.Cao		Released.	Mar 22, 2006

Notice:

Eoptolink reserves the right to make changes to or discontinue any optical link product or service identified in this publication, without notice, in order to improve design and/or performance. Applications that are described herein for any of the optical link products are for illustrative purposes only. Eoptolink makes no representation or warranty that such applications will be suitable for the specified use without further testing or modification.

Contact:

Add: Floor 5, Building 2, No. 21 Gaopeng Avenue, High-Tech District, CHENGDU, SICHUAN
610041 P.R. CHINA

Tel: (+86) 028-13122709 ext 816 & 809

Fax: (+86) 028-13121912

Postal: 610041

E-mail: sales@eoptolink.com

<http://www.eoptolink.com>