

EOLF-GEU5-10X Series

EOLF-GEU5-20X Series

ONU for 1000BASE-PX10/20-U

Single fiber bi-directional Transceiver

1.25Gbps upstream and 1.25Gbps downstream

RoHS6 Compliant

Features

- ◆ 2x5 SFF Package with SC Receptacle/SC Pigtail
- ◆ Single +3.3 V Power Supply
- ◆ 1.25 Gbps / 1310 nm Burst-Mode Transmitter with FP laser
- ◆ 1.25 Gbps / 1490 nm Continuous-Mode Receiver with 2R Output
- ◆ EOLF-GEU5-10X Distance up to 10km
EOLF-GEU5-20X Distance up to 20km
- ◆ LVTTTL transmitter burst-mode control
- ◆ LVTTTL receiver signal-detected indication
- ◆ Operating Case Temperature
Standard: 0°C~+70°C
- ◆ Class 1 FDA and IEC60825-1 laser safety compliant
- ◆ Compliant with IEEE 802.3ah-2004

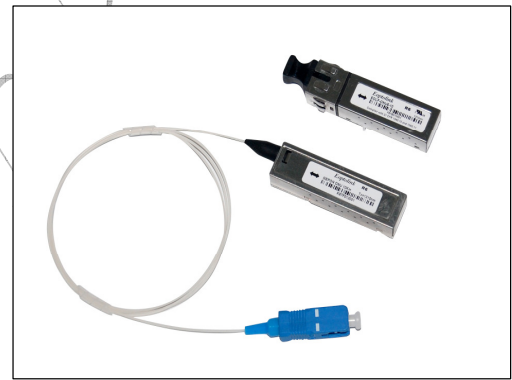

Applications

- ◆ Gigabit Ethernet GE-PON ONU for P2MP application
- ◆ Broadband GE-PON System

Ordering information

Part No.	Input	Output	Burst-mode	Fiber	Interface	Temperature
EOLF-GEU5-101 ^{*note1}	AC	AC	LVTTTL	SMF	SC	Standard
EOLF-GEU5-10P1	AC	AC	LVTTTL	SMF	Pigtail	Standard
EOLF-GEU5-10 ^{*note1}	DC	AC	LVTTTL	SMF	SC	Standard
EOLF-GEU5-10P	DC	AC	LVTTTL	SMF	Pigtail	Standard
EOLF-GEU5-201 ^{*note1}	AC	AC	LVTTTL	SMF	SC	Standard

EOLF-GEU5-20P1	AC	AC	LVTTTL	SMF	Pigtail	Standard
EOLF-GEU5-20* ^{note1}	DC	AC	LVTTTL	SMF	SC	Standard
EOLF-GEU5-20P	DC	AC	LVTTTL	SMF	Pigtail	Standard

Note1: Standard version

Note2: EOLF-GEU5-XP series is with pigtail, the fiber length is customized.

PON Nomenclature

EOL□-□□□-□□□□

A-BCD-EFGH

No.	Description	Option			
A	Package	F= SFF			
B	PON Type	GE=GEPON	G=GPON	B=BPON	
C	Application	U=ONU		T=OLT	
D	Form Type	5=2X5	6=2X6	A=2X10	
E	Distance	10=10km		20=20km	
F	Temp.	Blank=0~70°C		I=-40~+85°C	
G	Interface	Blank=SC		P=Pigtail/SC	
H	Tx coupling/Rx coupling/SD Logic	Blank=DC/AC/TTL	1=AC/AC/TTL	2=DC/DC/TTL	3=AC/DC/TTL

Regulatory Compliance

Feature	Standard	Performance
Electrostatic Discharge (ESD) to the Electrical Pins	MIL-STD-883G Method 3015.7	Class 1C (>1000 V)
Electrostatic Discharge to the enclosure	EN 55024:1998+A1+A2 IEC-61000-4-2 GR-1089-CORE	Compatible with standards
Electromagnetic Interference (EMI)	FCC Part 15 Class B EN55022:2006 CISPR 22B :2006 VCCI Class B	Compatible with standards Noise frequency range: 30 MHz to 6 GHz. Good system EMI design practice required to achieve Class B margins. System margins are dependent on customer host board and chassis design.
Immunity	EN 55024:1998+A1+A2 IEC 61000-4-3	Compatible with standards. 1kHz sine-wave, 80% AM, from 80 MHz to 1 GHz. No effect on transmitter/receiver performance is detectable

		between these limits.
Laser Eye Safety	FDA 21CFR 1040.10 and 1040.11 EN (IEC) 60825-1:2007 EN (IEC) 60825-2:2004+A1	CDRH compliant and Class I laser product. TüV Certificate No. 50135086
Component Recognition	UL and CUL EN60950-1:2006	UL file E317337 TüV Certificate No. 50135086 (CB scheme)
RoHS6	2002/95/EC 4.1&4.2 2005/747/EC 5&7&13	Compliant with standards ^{*note2}

Note2: For update of the equipments and strict control of raw materials, EOPTOLINK has the ability to supply the customized products since Jan 1th, 2007, which meet the requirements of RoHS6 (Restrictions on use of certain Hazardous Substances) of European Union.

In light of item 5 in RoHS exemption list of RoHS Directive 2002/95/EC, Item 5: Lead in glass of cathode ray tubes, electronic components and fluorescent tubes.

In light of item 13 in RoHS exemption list of RoHS Directive 2005/747/EC, Item 13: Lead and cadmium in optical and filter glass. The three exemptions are being concerned for Eoptolink's transceivers, because Eoptolink's transceivers use glass, which may contain Pb, for components such as lenses, windows, isolators, and other electronic components.

Functional Diagram

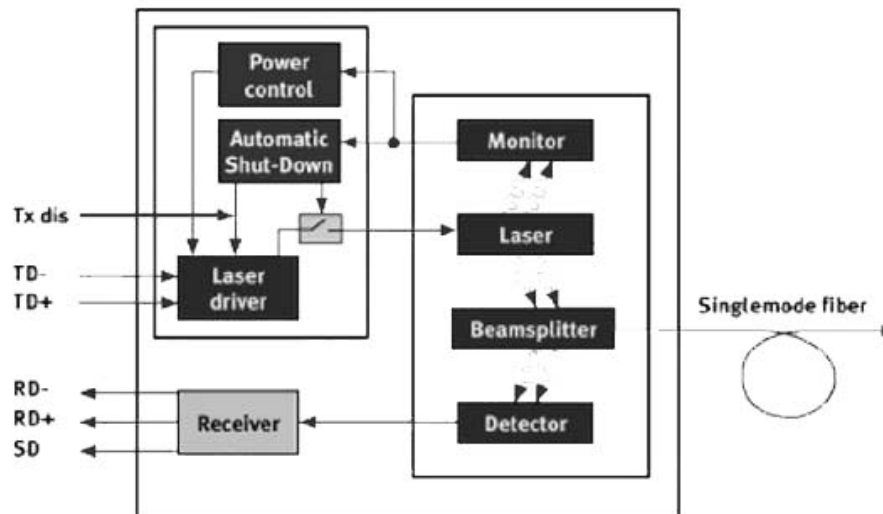

The Signal Detect (SD, active high), Normal optical input levels to the receiver result in a logic "1" output, asserted.

The following version is available:

1. AC/AC Transceiver

Standard PECL inputs and outputs, Tx is AC coupling.

2. DC/AC Transceiver

Standard PECL inputs and outputs, Tx is DC coupling.

Product Description

EOLF-GEU5-XX Series is a transceiver for the optical network unit (ONU) of GE-PON with 1.25Gbps in downstream and 1.25Gbps in upstream. EOLF-GEU5-XX series is high performance module for single fiber communications by using 1310nm burst-mode transmitter and 1490 nm continuous-mode receiver.

The transmitter section uses a multiple quantum well 1310nm laser and is a class 1 laser compliant according to International Safety Standard IEC-60825-1. The receiver section uses an integrated 1490 nm detector preamplifier (IDP) mounted in an optical header and a limiting post-amplifier IC.

LVPECL interface is used for differential inputs and outputs. A LVTTTL logic interface simplifies interface to external circuitry.

Absolute Maximum Ratings

Parameter	Symbol	Min.	Max.	Unit
Storage Temperature	T _s	-40	+85	°C
Supply Voltage	V _{CC}	-0.5	4.0	V
Operating Relative Humidity	Hopr	5	95	%
Wave Soldering Conditions Temp/Time			260/10	°C/s

*Exceeding any one of these values may destroy the device immediately.

Recommended Operating Conditions

Parameter	Symbol	Min.	Typical	Max.	Unit
Operating Case Temperature	T _A	0		+70	°C
Power Supply Voltage	V _{CC}	3.15	3.3	3.45	V
Power Supply Current	I _{CC}		200	250	mA
Date Rate			1.25		Gbps

Performance Specifications - Electrical

Parameter	Symbol	Min.	Typ.	Max	Unit	Notes
Transmitter						
LVPECL Inputs(Differential)	V _{in}	300		1600	mVpp	
Input Impedance (Differential)	Z _{in}	85	100	115	ohms	R _{in} = 100 ohms
Tx_Dis	L	0		0.8	V	
	H	2		V _{CC} +0.3		
Receiver						
LVPECL Outputs (Differential)	V _{out}	370		1600	mVpp	AC coupled outputs
Output Impedance (Differential)	Z _{out}	85	100	115	ohms	
Rx_SD	SD	2		V _{CC} +0.3	V	

	Normal		0		0.8	V	
--	--------	--	---	--	-----	---	--

Performance Specifications – Optical

(EOLF-GEU5-10X, FP & PIN/TIA)

Parameter	Symbol	Min.	Typical	Max.	Unit
9µmCore Diameter SMF			10		km
Data Rate			1.25		Gbps
Transmitter					
Centre Wavelength	λ_c	1276		1356	nm
Spectral Width (RMS)	$\Delta\lambda$			3.5	nm
Average Output Power ^{*(note3)}	P _{out}	-1		+4	dBm
Extinction Ratio ^{*(note4)}	ER	9			dB
Reflectance	R _t			-6	dB
Rise/Fall Time(20%~80%)	tr/tf			260	ps
Total Jitter(PRBS2 ⁷ -1)	T _J			0.35	UI
Output Optical Eye ^{*(note5)}	IEEE Std 802.3ah-2004 Compliant				
Optical Burst On Time	t _{on}			30	ns
Optical Burst Off Time	t _{off}			30	ns
Optical Output Power with TX OFF ^{*(note6)}	P _{off}			-45	dBm
Receiver					
Centre Wavelength	λ_c	1480	1490	1500	nm
Receiver Sensitivity ^{*(note6)}	P _{min}			-24	dBm
Saturation Optical Power	P _{max}	-3			dBm
Receiver Reflectance	CR			-12	dB
Optical Crosstalk				-47	dB
SD De-Assert	SDD	-32		-28	dBm
SD Assert	SDA	-23		-28	dBm
Signal Detect Hysteresis ^{*(note7)}		0.5		6	dB
Optical Isolation from external source	1260~1360nm			-38	dB
	1550~1560nm			-35	
	1640~1660nm			-20	

(EOLF-GEU5-20X, FP & PIN/TIA)

Parameter	Symbol	Min.	Typical	Max.	Unit
9µmCore Diameter SMF			20		km
Data Rate			1.25		Gbps
Transmitter					
Centre Wavelength	λ_c	1276		1356	nm
Spectral Width (RMS)	$\Delta\lambda$			2.5	nm
Average Output Power ^{*(note3)}	P _{out}	-1		+4	dBm
Extinction Ratio ^{*(note4)}	ER	9			dB

Reflectance	Rt			-6	dB
Rise/Fall Time(20%~80%)	tr/tf			260	ps
Total Jitter(PRBS ^{2⁷} -1)	T _J			0.35	UI
Output Optical Eye*(note5)	IEEE Std 802.3ah-2004 Compliant				
Optical Burst On Time	t _{on}			30	ns
Optical Burst Off Time	t _{off}			30	ns
Optical Output Power with TX OFF*(note6)	P _{off}			-45	dBm
Receiver					
Centre Wavelength	λ _c	1480	1490	1500	nm
Receiver Sensitivity*(note6)	P _{min}			-26	dBm
Saturation Optical Power	P _{max}	-3			dBm
Receiver Reflectance	CR			-12	dB
Optical Crosstalk				-47	dB
SD De-Assert	SDD	-32		-28	dBm
SD Assert	SDA	-23		-28	dBm
Signal Detect Hysteresis*(note7)		0,5		6	dB
Optical Isolation from external source	1260~1360nm			-38	dB
	1550~1560nm			-35	
	1640~1660nm			-20	

Note3: Output is coupled into a 9/125 um single-mode fiber.

Note4: Filtered, Measured with PRBS^{2⁷}-1 test pattern @1.25Gbps.

Note5: Eye pattern mask

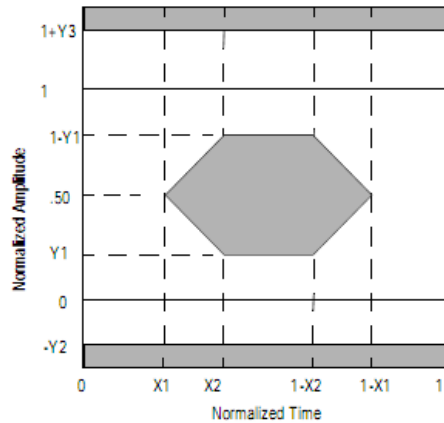

Note 6: Measured with a PRBS ^{2⁷}-1 test pattern @1.25Gbps and ER=9dB, BER is less than 1E-12.

Note7: LOS Hysteresis

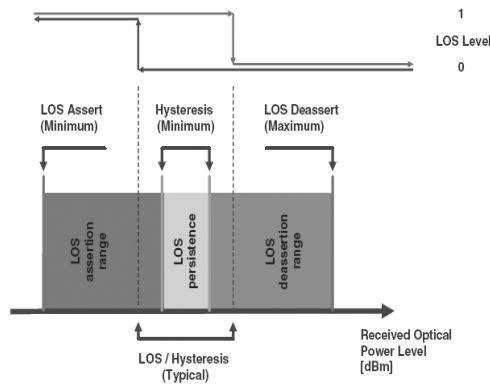

GEPON Transceiver Electrical Pad Layout



SC Receptacle

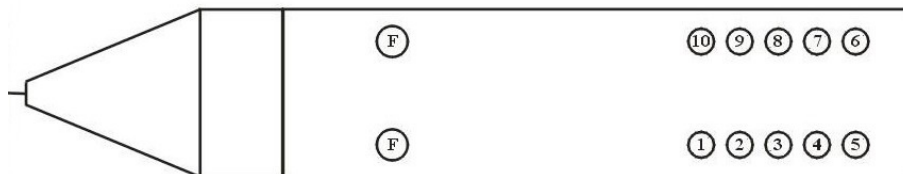

SC Pigtail

Pin Function Definitions

Pin Num.	Name	Description
1	VeeR	Connected to ground plane of the receiver.
2	VccR	+3.3V nominal DC power supply for the receiver section.
3	SD	Signal Detect output. LVTTTL. Active "low" indicates a loss of optical input signal
4	RD-	Inverting data output (LVPECL) (AC coupled internally).
5	RD+	Non-inverting data output (LVPECL) (AC coupled internally).
6	VccT	+3.3V nominal DC power supply for the transmitter section.

7	VeeT	Connected to ground plane of the transmitter.
8	TXDIS	LVTTTL Transmitter burst mode control, "L": Tx ON or "H": Tx ON.(selectable) Default "H": Tx ON.
9	TD+	Non-inverting data input (LVPECL).
10	TD-	Inverting data input (LVPECL).

Eoptolink

Recommend Circuit Schematic

DC/AC Coupling

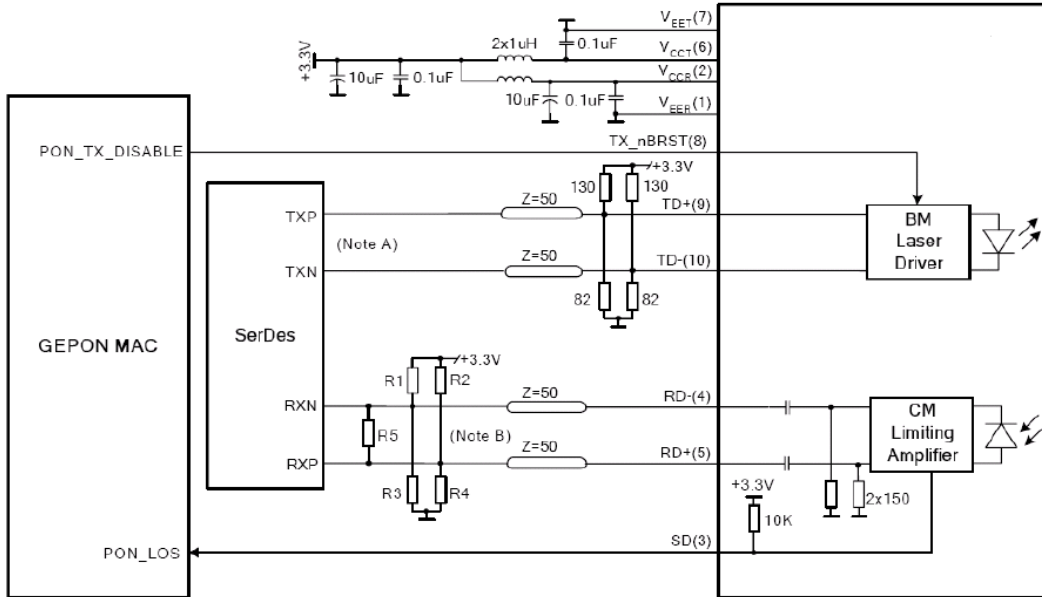

AC/AC Coupling

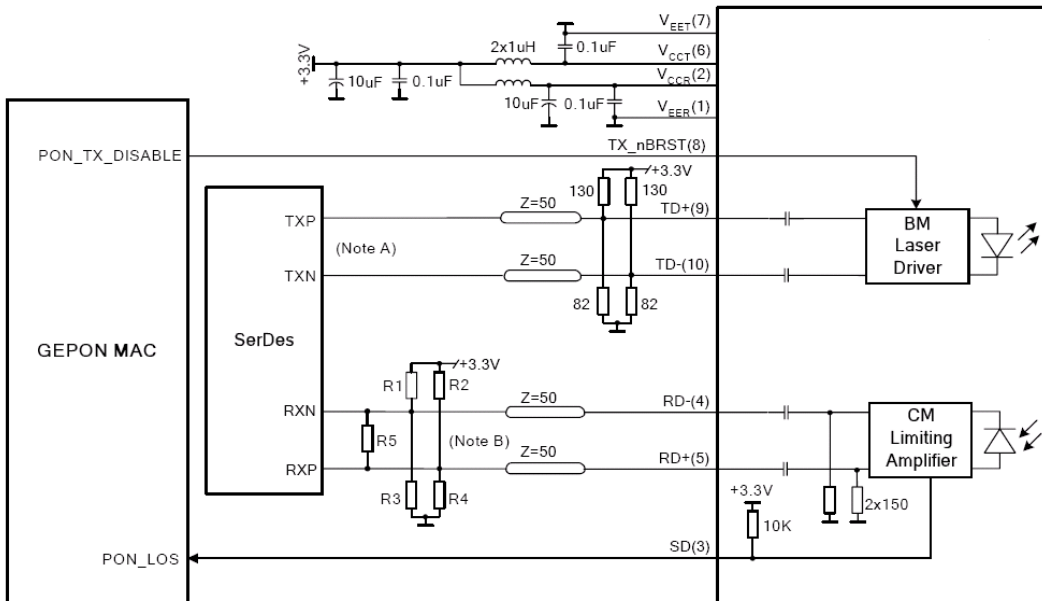

Note A: Open emitter output internally.

Note B: LVPECL output, AC coupled internally.

Input stage in SerDes IC is assumed with high impedance and internal bias to V_{cc}-1.3V

R1=R2=R3=R4=N.C

Input stage in SerDes IC is assumed without internal bias to V_{cc}-1.3V

R1=R2=82Ω, R3=R4=130Ω

Burst Mode Sequence

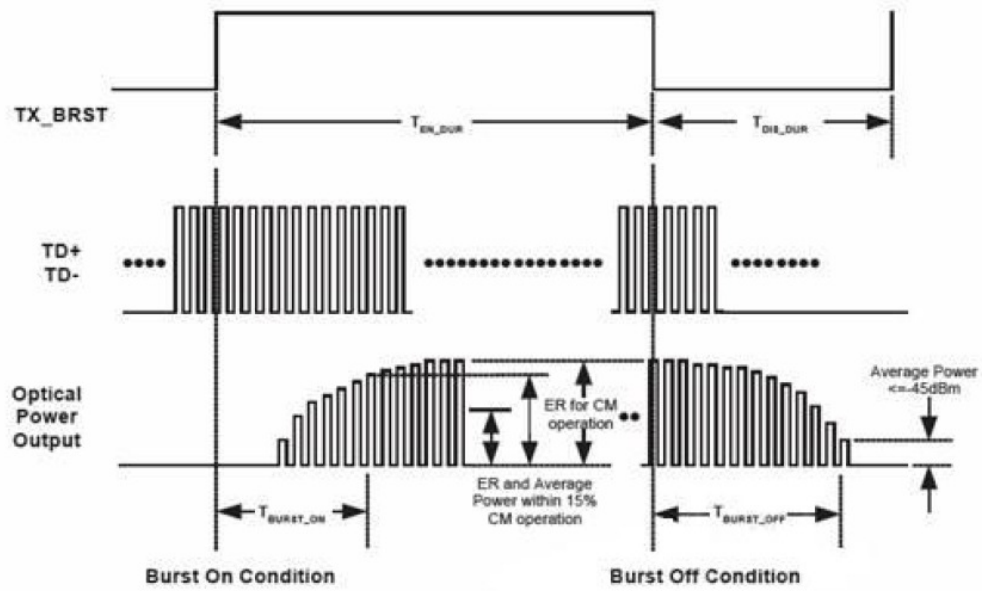

Mechanical Specifications

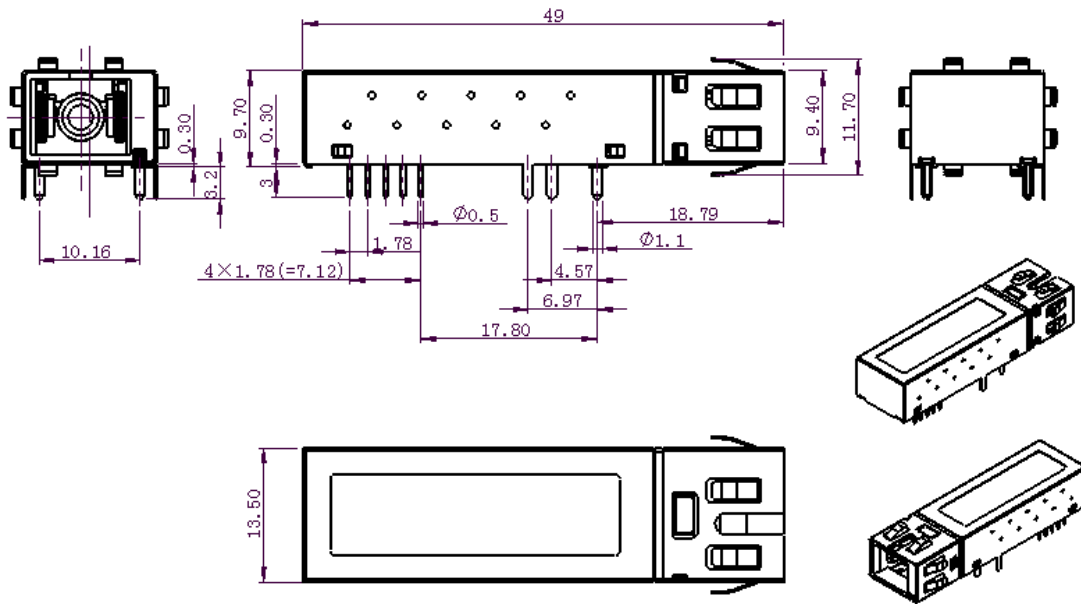

SC Receptacle

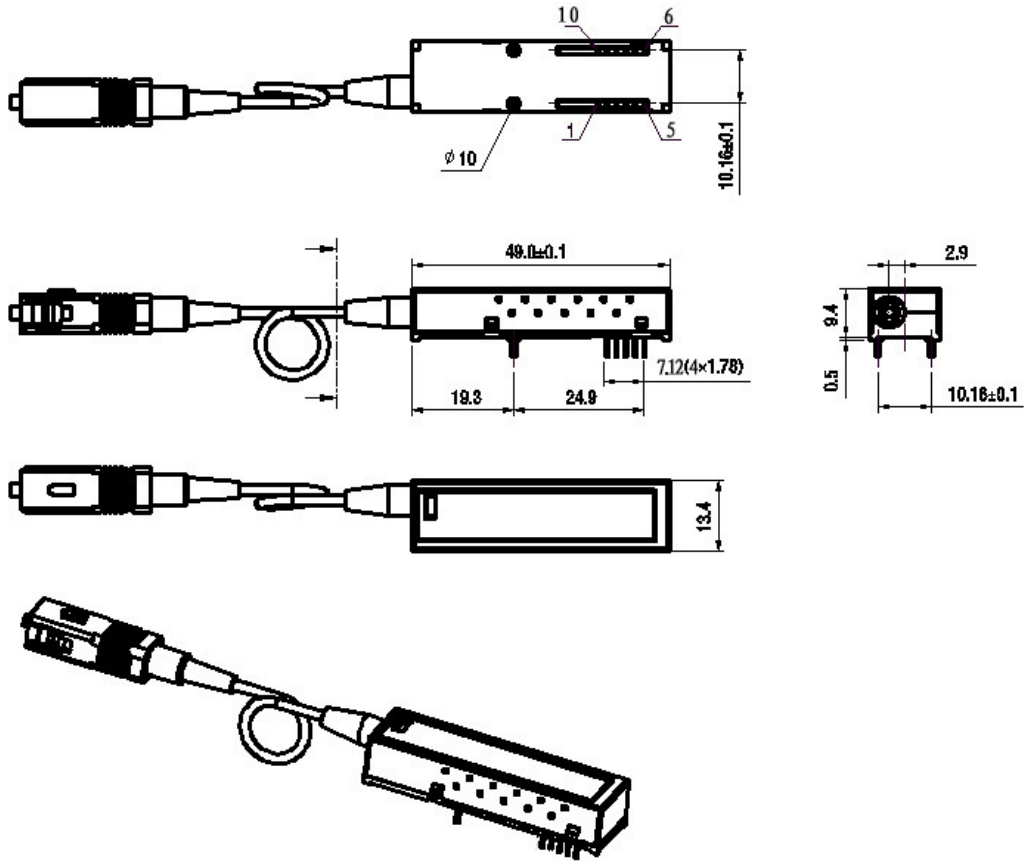

SC Pigtail

Class 1 Labels

FDA	Complies with 21 CFR 1040.10 and 1040.11
IEC	Class 1 Laser Product

Laser Emission Data

Wavelength	1310nm
Total output power (as defined by FDA: 7 mm aperture at 20 cm distance)	<0.195mW
Total output power (as defined by IEC: 7 mm aperture at 10 cm distance)	<15.6mW
Beam divergence	12.5°

Laser Emission

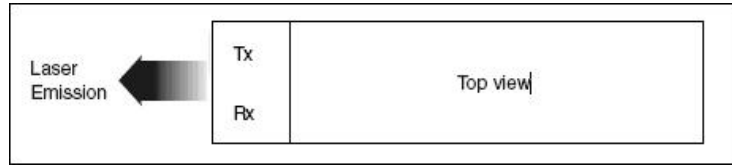

Eoptolink

Obtaining Document

Please contact Eoptolink Technology Inc., Ltd. listed at the end of the documentation to get the latest documents.

Revision History

Revision	Initiated	Reviewed	Approved	DCN	Release Date
V5.a	Cathy	Kelly		Integrate 10km & 20km products.	Mar 12, 2009

Notice:

Eoptolink reserves the right to make changes to or discontinue any optical link product or service identified in this publication, without notice, in order to improve design and/or performance. Applications that are described herein for any of the optical link products are for illustrative purposes only. Eoptolink makes no representation or warranty that such applications will be suitable for the specified use without further testing or modification.

Contact:

Add: Floor 5 Building 2 No. 21 Gaopeng Avenue High-Tech District CHENGDU, SICHUAN 610041

P.R. CHINA

Tel: (+86) 028-85122709 ext 816 & 809

Fax: (+86) 028-85121912

Postal: 610041

E-mail: sales@eoptolink.com