

2X10 EOLF-GUA-20 Series

Class B+ ONU for GPON

Single Fiber Bi-Directional WDM Transceiver

1.244Gbps Upstream and 2.488Gbps Downstream

RoHS6 Compliant

Features

- ◆ 2X10 SFF Package With SC Receptacle, SC Pigtail
- ◆ 1.244Gbps, 1310nm Burst Mode Transmitter
- ◆ 2.488Gbps, 1490nm Continuous Mode Receiver
- ◆ Un-cooled DFB Laser and APD High Sensitivity Detector
- ◆ Up to 20km Distance at 9/125μm G.652 SMF With 32:1 Split Ratio
- ◆ Single 3.3V Power Supply
- ◆ LVTTTL Tx_Dis and SD
- ◆ Class 1 FDA and IEC60825-1 Laser Safety Compliant
- ◆ Operating Case Temperature
Standard: 0°C~+70°C
Industry: -40°C~+85°C
- ◆ Compliant with ITU-T G.984.2 and G.984.2 Amendent-2006
- ◆ Compliant with SFF MSA Specification
- ◆ Burst mode Tx DDMI function

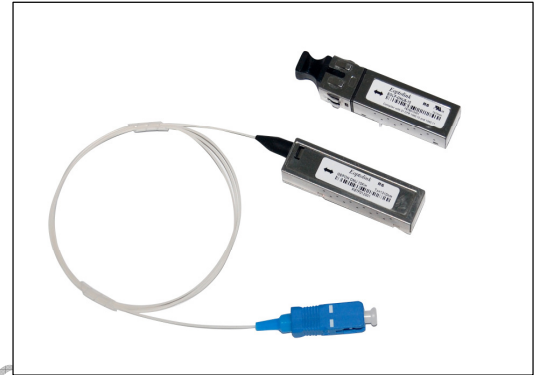

Applications

- ◆ Access Networks
- ◆ Fiber to the Home, Curb, Office (FTTx)

Ordering Information

Part No.	Input/Output	Distance (32:1)	Burst-mode	DDMI	Interface	Temp.
EOLF-GUA-20D ^{*(note1)}	DC/AC	20km	LVTTTL	YES	SC	0°C~+70°C
EOLF-GUA-20DI	DC/AC	20km	LVTTTL	YES	SC	-40°C~+85°C
EOLF-GUA-20DP	DC/AC	20km	LVTTTL	YES	Pigtail	0°C~+70°C
EOLF-GUA-20DIP	DC/AC	20km	LVTTTL	YES	Pigtail	-40°C~+85°C

Note1: Standard Version

Regulatory Compliance

Feature	Standard	Performance
Electrostatic Discharge (ESD) to the Electrical Pins	MIL-STD-883G Method 3015.7	Class 1C (>1000 V)
Electrostatic Discharge to the enclosure	EN 55024:1998+A1+A2 IEC-61000-4-2 GR-1089-CORE	Compatible with standards
Electromagnetic Interference (EMI)	FCC Part 15 Class B EN55022:2006 CISPR 22B :2006 VCCI Class B	Compatible with standards Noise frequency range: 30MHz to 6GHz. Good system EMI design practice required to achieve Class B margins. System margins are dependent on customer host board and chassis design.
Immunity	EN 55024:1998+A1+A2 IEC 61000-4-3	Compatible with standards. 1KHz sine-wave, 80% AM, from 80MHz to 1GHz. No effect on transmitter/receiver performance is detectable between these limits.
Laser Eye Safety	FDA 21CFR 1040.10 and 1040.11 EN (IEC) 60825-1:2007 EN (IEC) 60825-2:2004+A1	CDRH compliant and Class I laser product. TüV Certificate No. 50135086
Component Recognition	UL and CUL EN60950-1:2006	UL file E317337 TüV Certificate No. 50135086 (CB scheme)
RoHS6	2002/95/EC 4.1&4.2 2005/747/EC 5&7&13	Compliant with standards ^{*note2}

Note2: For update of the equipments and strict control of raw materials, EOPTOLINK has the ability to supply the customized products since Jan 1, 2007, which meet the requirements of RoHS6 (Restrictions on use of certain Hazardous Substances) of European Union.

In light of item 5 in RoHS exemption list of RoHS Directive 2002/95/EC, Item 5: Lead in glass of cathode ray tubes, electronic components and fluorescent tubes.

In light of item 13 in RoHS exemption list of RoHS Directive 2005/747/EC, Item 13: Lead and cadmium in optical and filter glass. The three exemptions are being concerned for Eoptolink's transceivers, because Eoptolink's transceivers use glass, which may contain Pb, for components such as lenses, windows, isolators, and other electronic components.

Functional Diagram

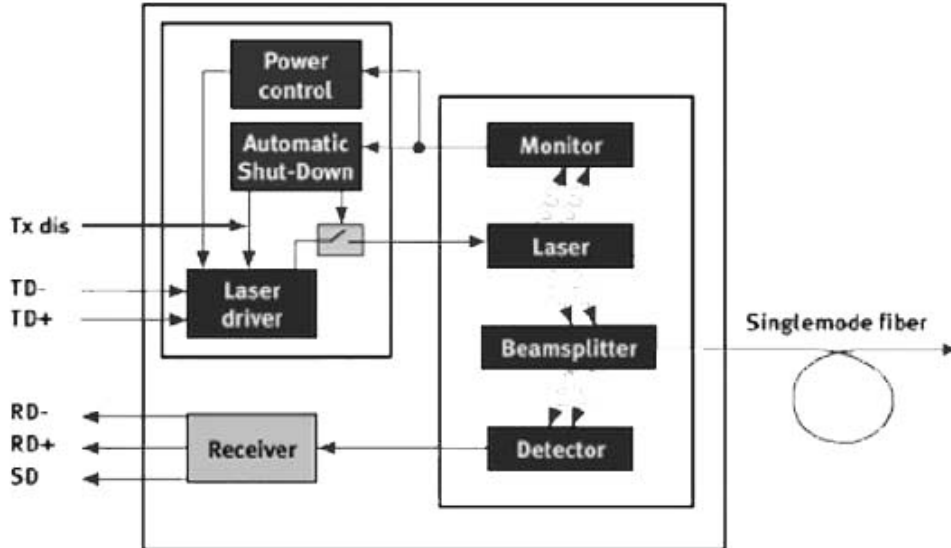

The Signal Detect (SD), Logic "1" represents the normal optical input level.

The following versions are available:

1. DC/AC Transceiver

Standard PECL inputs and CML outputs, TX is DC coupling and RX is AC coupling.

Product Description

Eoptolink's high performance GPON ONU transceiver is designed for passive optical network application. It can fully support the Class B+ ODN application specified by the ITU-T G.984.2 standard and ITU-T G.984.2 Amendent1.

The GPON ONU transceiver is packaged of small form factor 2x10 with a pigtail and SC connector. The digital diagnostic monitoring function is compliant with SFF 8472 MSA.

The module consists of 1310nm un-cooled DFB Laser, InGaAs preamplifier and WDM filter in a high-integrated optical sub-assembly. It transmits 1.244Gbps at 1310nm in burst mode and receives 2.488Gbps at 1490nm in continuous mode.

Absolute Maximum Ratings^{*Note3}

Parameter	Symbol	Min.	Max.	Unit
Storage Temperature	T _S	-40	+85	°C
Supply Voltage	V _{CC}	-0.5	4.0	V
Operating Relative Humidity		-	95	%
Wave Soldering Conditions Temp/Time		-	260/10	°C/s

*Note3: Exceeding any one of these values may destroy the device immediately.

Recommended Operating Conditions

Parameter	Symbol	Min.	Typical	Max.	Unit	
Operating Case Temperature	T _A	EOLF-GUA-20D	0	-	70	°C
		EOLF-GUA-20DI	-40	-	85	
Power Supply Voltage	V _{CC}	3.15	3.3	3.45	V	
Power Supply Current	I _{CC}	-	-	300	mA	
Date Rate	Upstream/Downstream	-	1.244/2.488	-	Gbps	

Performance Specifications - Electrical

Parameter	Symbol	Min.	Typ.	Max	Unit	Notes	
Transmitter							
Tx DC Supply Current	I _{CC}	-	-	150	mA		
LVPECL Inputs(Differential)	V _{in}	300	-	1900	mVpp	DC coupled inputs	
Input Impedance (Differential)	Z _{in}	85	100	115	ohm	R _{in} > 100 kohm @ DC	
Tx_Dis	Tx ON / Enable	V _{IH}	2	-	V _{CC} +0.3	V	LVTTL, Control Input
	Tx Off / Disable	V _{IL}	0	-	0.8		
Receiver							
Rx Supply Current	I _{CC}	-	-	125	mA		
CML Outputs (Differential)	V _{out}	600	-	1900	mVpp	AC coupled outputs	
Output Impedance (Differential)	Z _{out}	85	100	115	ohm		
RX_SD	Normal	2	-	V _{CC} +0.3	V		
	SD	0	-	0.8	V		
I²C Serial Logic							
I2C Serial Data	SDA_H	2	-	V _{CC} +0.3	V		
	SDA_L	0	-	0.8	V		
I2C Serial Clock	SCL_H	2	-	V _{CC} +0.3	V		
	SCL_L	0	-	0.8	V		

Performance Specifications - Optical

Parameter	Symbol	Min.	Typical	Max.	Unit
9µmCore Diameter SMF	L	-	20	-	km
Date Rate (Upstream/Downstream)	R	-	1.244/2488	-	Gbps
Transmitter					
Centre Wavelength	λ _C	1260	1310	1360	nm
-20dB Spectral Width	Δλ	-	-	1	nm

Side Mode Suppression Ratio	SMSR	30	-	-	dB
Average Output Power (B.O.L) ^{*(note4)}	P _{out}	1	-	5	dBm
Average Output Power (E.O.L) ^{*(note4)}	P _{out}	0.5	-	4.5	dBm
Extinction Ratio ^{*(note5)}	ER	10	-	-	dB
Rise/Fall Time (Optical, 10%~90%)	t _R ,t _F	-	0.15	0.26	ns
Output Optical Eye ^{*(note6)}	ITU-T G984.2 Compliant				
Optical Burst On/ Off Time	t _{on} /t _{off}	-	-	12.8	ns
Additive Jitter Generation	J _A	-	-	0.2	UI
Optical Output Power with TX OFF ^{*(note4)}	P _{off}	-	-	-45	dBm
Transmitter and Dispersion Penalty	TDP	-	-	0.5	dB
Transmit Reflectance	RFL	-	-	-30	dB
Optical Return Loss	R _L	-	-	15	dB
Receiver					
Centre Wavelength	λ _c	1480	1490	1500	nm
Receiver Sensitivity ^{*(note7)}	P _{min}	-	-	-28	dBm
Saturation Optical Power	P _{max}	-8	-	-	dBm
Damage Threshold	P _{DT}	-	-	4	dBm
Receiver Reflectance	R _f	-	-	-20	dB
Polarization Dependent Loss	PDL	-	-	0.5	dB
SD Assert	SDA	-	-	-29	dBm
SD De-Assert	SDD	-40	-	-	dBm
Signal Detect Hysteresis ^{*(note8)}		0.5	2	6	dBm

Note4: Measured with 9/125um G.652 SMF. B.O.L=Begin of Life, E.O.L=End of Life.

Note5: Filtered, measured with PRBS2³¹-1 test pattern @1.244Gbps.

Note6: Eye Pattern Mask.

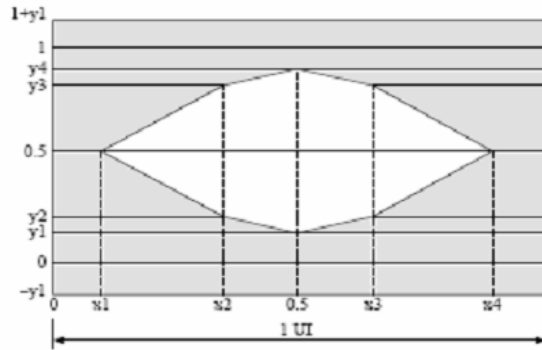

Note 7: Measured with a PRBS 2³¹-1 test pattern @1.244Gbps and ER=10dB, BER 1X10⁻¹².

Note 8: SD Hysteresis

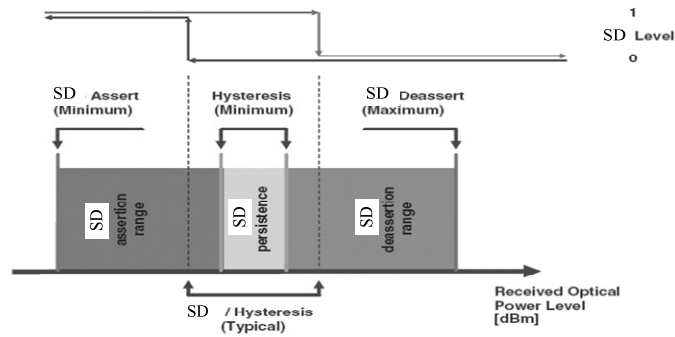

Transmitter Burst Mode Timing Characteristics

VccT	Burst control	Data Input	Optical Output
VccT < 2.5V	X	X	OFF
VccT > 3.13V	Low	X	OFF
	High/NC	NO	Other
		Yes	Laser bias and modulation signal output

“X” means don’t care.

“Other” means peak power less than +8dBm.

“High/Low” means Logic high/low level.

“No” means data not present, “Yes” means data present.

“OFF” means the optical power less than -45dBm.

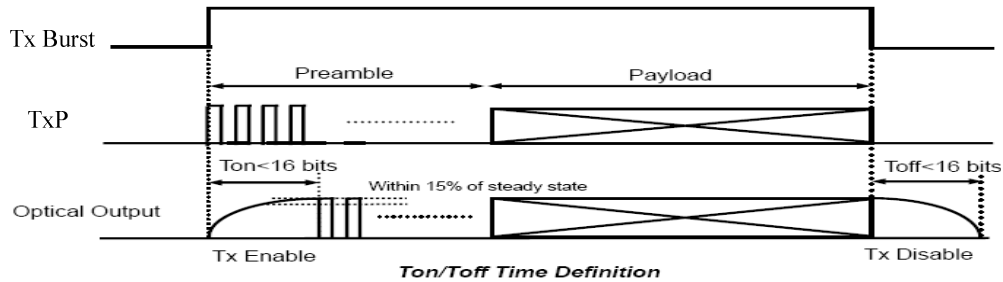

Burst transmitter timing

Enhanced Digital Diagnostic Interface

The memory map in the following describes an extension to the memory map defined in SFF-8472 MSA. The enhanced interface uses the two wire serial bus address 1010001X (A2H) to provide diagnostic information about the module’s present operating conditions.

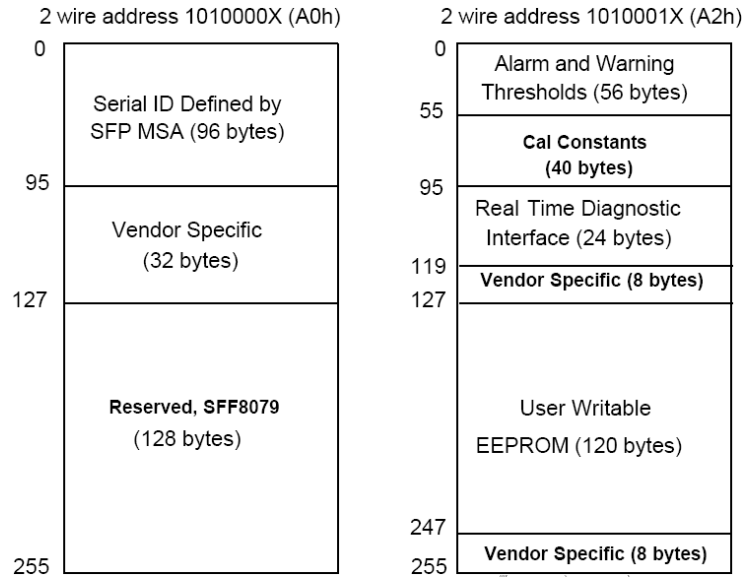

EEPROM Serial ID Memory Contents (2-Wire Address A0H)

The following diagnostic information is according to the EOLF-GUA-20DP Series.

Address	Name of Field	Hex	Description
Base ID Fields			
00	Identifier	02	SFF physical device (soldered device)
01	Ext. Identifier	04	Serial ID module supported
02	Connector	0B	Optical pigtail
03-10	Transceiver Codes	00	Undefined for GPON
11	Encoding	03	Compatible with NRZ encoding code
12	BR, Nominal	0C	Nominal 1244Mbps (indicate transmitter data rate)
13	Reserved	00	-
14	Length (9um)-km	14	20km @9/125um fiber
15	Length (9um)-100m	C8	20000m @9/125um fiber
16-18	Length for MMF	00	Undefined for GPON
19	Reserved	00	-
20-35	Vendor Name	XX	Note
36	Channel Spacing	00	Undefined
37~39	Vendor OUI	XX	Note
40-55	Vendor P/N	XX	Note
56-59	Vendor P/N Rev.	XX	Note
60-61	Laser Wavelength	05 1E	1310nm in Hex byte
62	DWDM Wavelength Fraction	00	Reserved.
63	CC_BASE	XX	Check sum of byte 0-62
Extended ID Fields			

64-65	Options	00 1A	Signal Detect is implemented
66	BR, Max.	00	Undefined
67	BR, Min.	00	Undefined
68-83	Vendor SN	XX	Vendor serial number in ASCII character, Note
84-91	Date Code	XX	Vendor date code in ASCII character, Note
92	Diagnostic Monitoring Type	58	Implemented with external calibration and received power measurement type by Avg. power
93	Enhanced options	F0	Alarm/Warning flags monitor are implemented
94	SFF-8472 compliant	03	SFF-8472 compliant with revision 10.2
95	CC_EXT	XX	Check sum of bytes 64-94
Vendor Specific ID Fields			
96-127	Vendor Specific	00	Vendor specific EEPROM
128-255	Reserved	00	Reserved for future use

*Note: The "XX" byte should be filled in according to practical case. For more information, please refer to the related document of SFF Multi-Source Agreement (MSA).

Digital Diagnostic Monitoring Interface (2-Wire Address A2H)

The interface uses the two wire serial bus address 1010001X (A2H) to provide diagnostic monitoring information about the module's present operating conditions as defined in SFF-8472 MSA, the monitoring range, accuracy and calibration method is as following table.

Monitoring Specification

Parameter	Range	Accuracy	Calibration
Temperature	-45 to +85°C	± 3°C	External
Voltage	3.0 to 3.6V	± 3%	External
Bias Current	0 to 100mA	±10%	External
TX Power	-1 to +6dBm	± 3dB	External
RX Power	-29 to -7dBm	± 3dB	External

SFF 2x10 Pin Function Definitions

TX/RX	Pin No.	I/O	Pin Name	Description
RX	1		NC	No Function Definition
	2		VeeR	Receiver Ground
	3		VeeR	Receiver Ground
	4		VeeR	Receiver Ground
	5		NC	No Function Definition
	6		VeeR	Receiver Ground
	7		VccR	+3.3V Receiver Power Supply

GPON ONU/ONT Series

	8	O	SD	Normal Optical Input indicated by logic “High”, and No Optical Input indicated by logic “Low”.
	9	O	RD(n)	Inverted Receiver Data Output (AC-Coupled internally)
	10	O	RD(p)	Non-Inverted Receiver Data Output (AC-Coupled internally)
TX	11		VccT	+3.3V Transmitter Power Supply
	12		VeeT	Transmitter Ground
	13	I	Tx Burst	LVTTTL, Logic “High” to Enable Burst Transmitter, and Disable Burst Transmitter by Logic “Low”.
	14	I	TD(p)	Non-Inverted Transmitter Data Input (DC-Coupled)
	15	I	TD(n)	Inverted Transmitter Data Input (DC-Coupled)
	16		VeeT	Transmitter Ground (Mod-Def 0)
	17	I	SCL	I2C Serial Clock (LVTTTL) (Mod-Def 1)
	18	I/O	SDA	I2C Serial Data (LVTTTL) (Mod-Def 2)
	19		NC	No Function Definition
	20		NC	No Function Definition
			F	Mounting Studs/Connect this pin to Chassis ground

The following figure illustrates the SFF 2x10 pin arrangement.

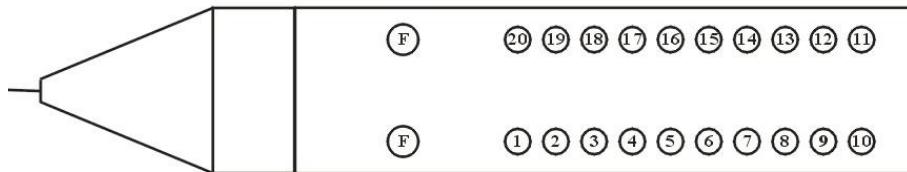

Pin arrangement

Recommended Circuit Schematic

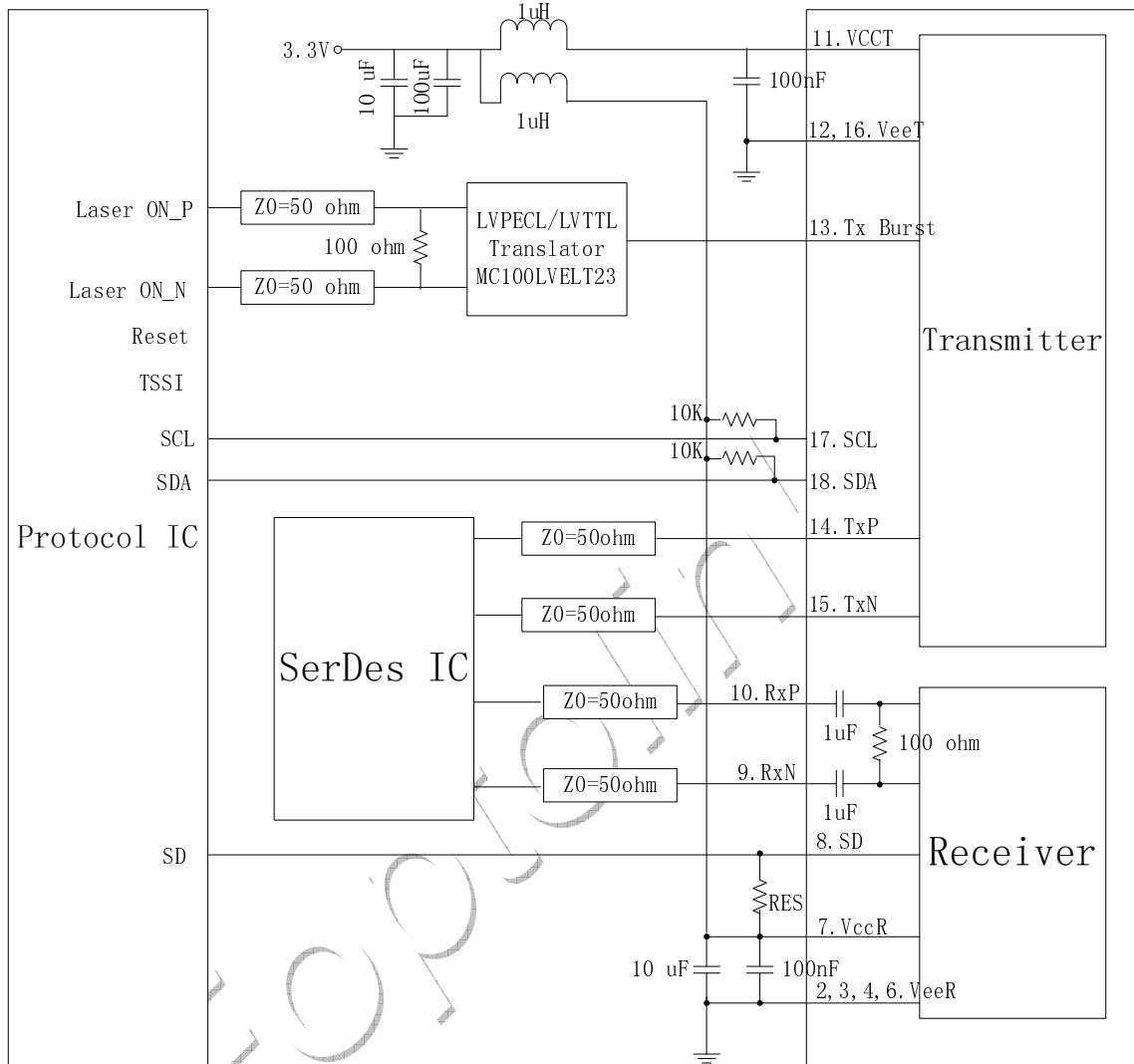

*RES is external 4.7K to 10K ohm pull-up resistor

2x10

Mechanical Specifications

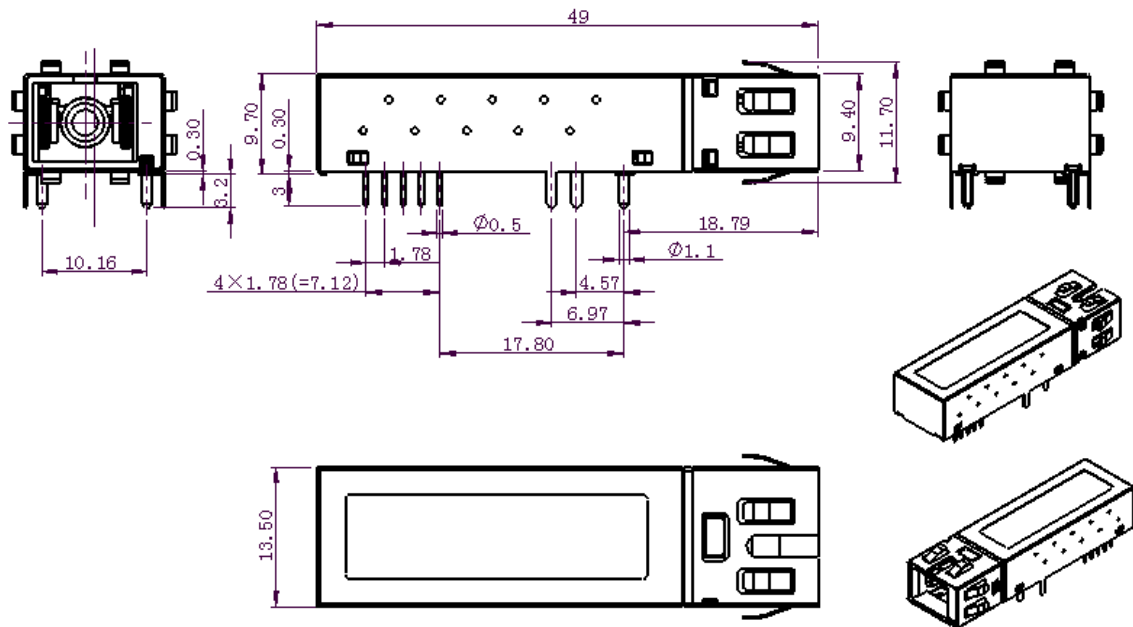

SC Receptacle

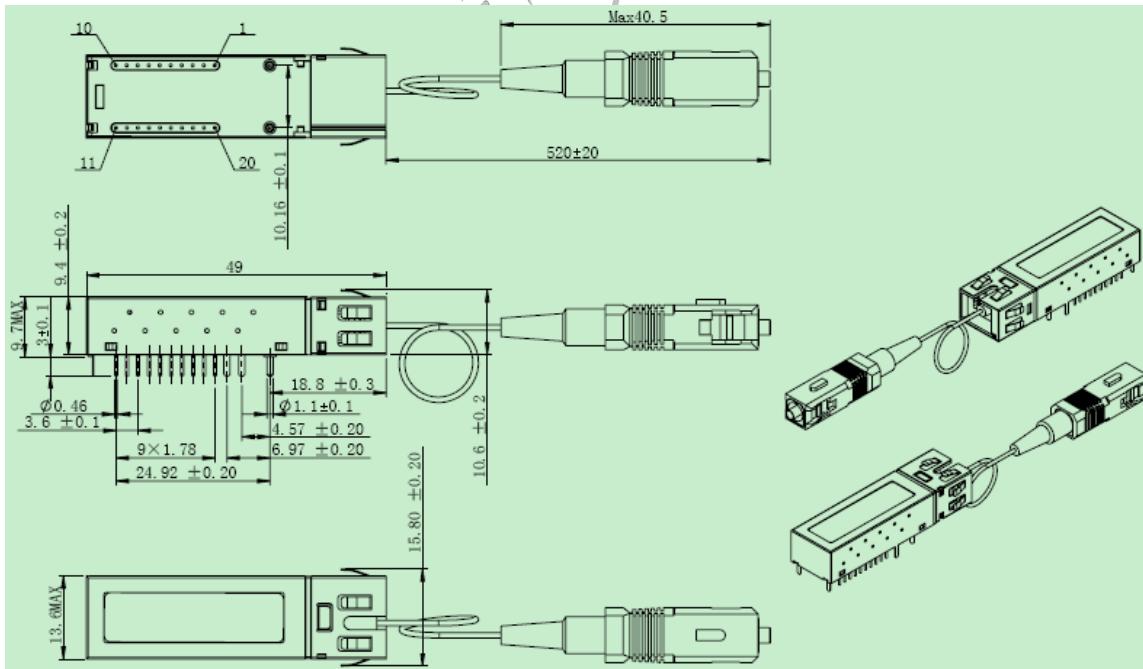

Pigtail with SC Connector

Class 1 Labels

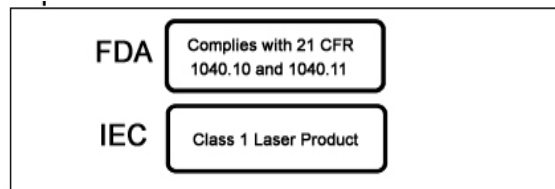

Laser Emission Data

Wavelength	1310nm
Total output power (as defined by FDA: 7mm aperture at 20cm distance)	<0.195mW
Total output power (as defined by IEC: 7mm aperture at 10cm distance)	<15.6mW
Beam divergence	17.25°

Laser Emission

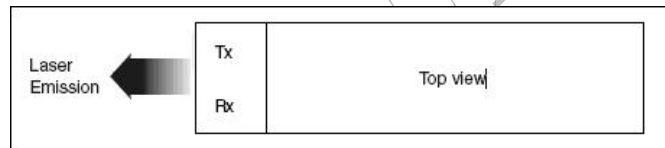

Obtaining Document

You can visit our website:

<http://www.eoptolink.com>

Or contact Eoptolink Technology Inc., Ltd. listed at the end of the documentation to get the latest documents.

Revision History

Revision	Initiated	Reviewed	Approved	Description	Release Date
V1.a	Kelly.Cao			Initial	Mar 25, 2009
V1.b	Kelly.Cao			Correct A0H, A2H	May 12, 2009
V1.c	Phlio.chen	Kelly.Cao		Modify 20PIN 19PIN definition	Dec 12, 2009
V1.d	Kelly.Cao			Correct the output power, SDD/SDA, pigtail diagram, Hysteresis	Jan 9, 2010

				maximum.	
--	--	--	--	----------	--

Notice:

Eoptolink reserves the right to make changes to or discontinue any optical link product or service identified in this publication, without notice, in order to improve design and/or performance. Applications that are described herein for any of the optical link products are for illustrative purposes only. Eoptolink makes no representation or warranty that such applications will be suitable for the specified use without further testing or modification.

Contact:

Add: Floor 5, Building 2, No. 21 Gaopeng Avenue, High-Tech District, CHENGDU, SICHUAN
610041 P.R. CHINA

Tel: (+86) 028-85122709 ext 816 & 809

Fax: (+86) 028-85121912

Postal: 610041

E-mail: sales@eoptolink.com

<http://www.eoptolink.com>

EOPTOLINK