

LC-ROSA2J713XB

1.25Gbps PIN-TIA Receiver with Receptacle Modules



Features

- ◆ High sensitivity
- ◆ Differential ended output
- ◆ Single +3.3V operation
- ◆ Trans-impedance amplifier with AGC
- ◆ RoHS Compliant Products Available

Applications

- ◆ 1.25Gbps application
- ◆ SDH/SONET application

General

LC-ROSA2J713XB Series is a 4 pin or 5 pin PIN-TIA with Receptacle operating on 1.25Gbps. It provides high sensitivity with AGC, 100ohm differential outputs and the 5 pin PIN-TIA provides a monitor pin. A split sleeve for the optical connector is jointed with Ø1.25mm ferrule.

Ordering Information (Standard version^{Note1})

Part No.	Insulation	Wavelength(nm)	Voltage (V)	Pin Type
LC-ROSA27130B	NO	1270~1620	3.3	A
LC-ROSA2J7130B	YES	1270~1620	3.3	A
LC-ROSA2713DB	NO	1270~1620	3.3	D
LC-ROSA2J713DB	YES	1270~1620	3.3	D

*Note1: For more ordering information, please refer the nomenclature and contact EPOTOLINK sales.

Absolute maximum ratings

Parameter	Min	Typ.	Max	Unit
Storage Temperature	-40	25	85	□
Operating Temperature	-40	25	85	□
TIA Supply Voltage	3.1	3.3	3.5	V
Operation Relative Humidity	-		85	%
Soldering Temperature / Time	-		260/10	°C/S

Electrical and optical characteristics

Parameter	Symbol	Min.	Typ.	Max.	Unit	Test Condition
Operating Wavelength	λ	1270		1620	nm	
Supply Current	I _{cc}		30	40	mA	No Loads
Saturation Power	P _{sat}	0	0	-	dBm	@ 1310nm
Small-Signal Bandwidth	BW	700			MHz	
Low-Frequency Cut off	LF			5	kHz	
Sensitivity				-25	dBm	$\lambda = 1310 \text{ nm}$, @1.25Gbps, PRBS7, ER=10dB, BER=1E-10
Single Ended Output Impedance	R	35	50	60	Ω	
Rise /FallTime	T		300	400	ps	20~80%

Pin Assignment ^{Note2}

TYPE: A

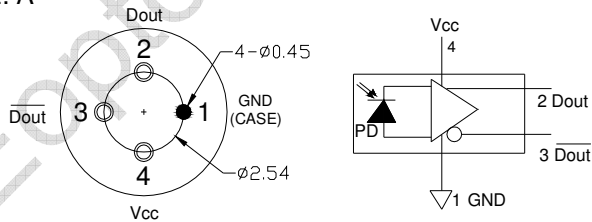

PIN-TIA-pin-A

TYPE: D

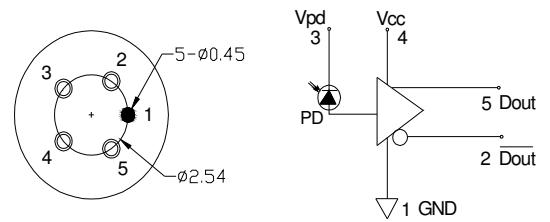

PIN-TIA-pin-D

Note2: Other Pin type can be customized.

Package dimension ^{Note3}

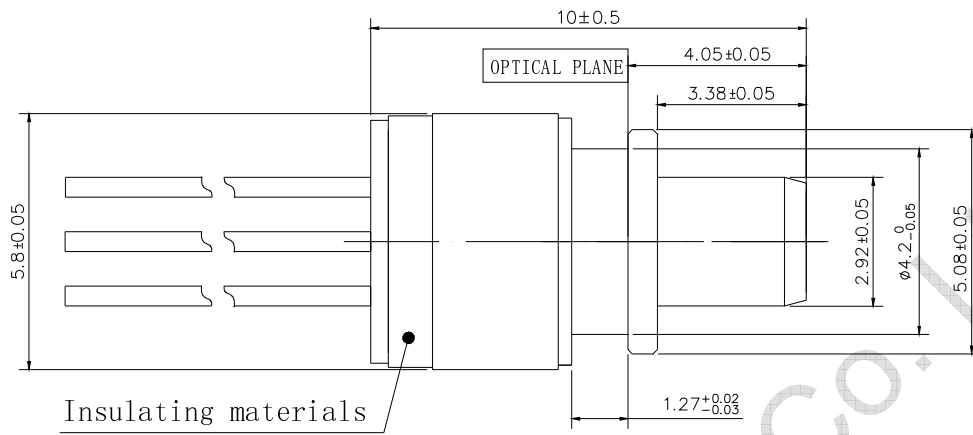

Insulation

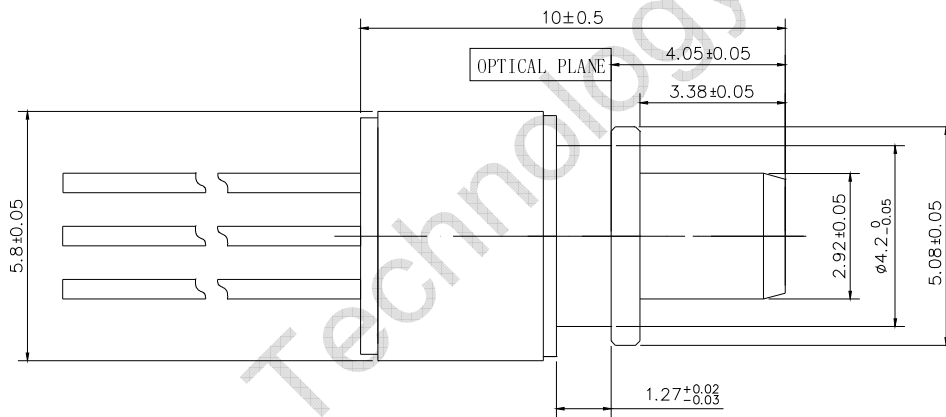

Not insulated

*Note3: Insulation is the TO-CAN and the metal pipe insulation.

Nomenclature

LC—ROSA2 □ □ □ □ □ □
 A B C D E F

A	Insulation	J= Insulation	BLANK=Non-insulated structure
B	Date rate	7=1.25Gbps	
C	Wavelength	1=1270~1620nm	
D	Voltage	3=3.3V	
E	Pin Type	0= pin-A	D= pin-D
F	Ferrule sets of type	Ferrule sets of type B	

Precaution

- (1) The modules should be handled in the same manner as ordinary semiconductor devices to prevent the electro-static damages. For safe keeping and carrying, the modules should be packaged with ESD proof material. To assemble the modules on PCB, the workbench, the soldering iron and the human body should be grounded.
- (2) Please pay special attention to the atmosphere condition because the dew on the module may cause some electrical damages.
- (3) Under such a strong vibration environment as in automobile, the performance and reliability are not guaranteed.

Obtaining Document

You can visit our website:

<http://www.eoptolink.com>

Or contact Eoptolink Technology Inc., Ltd. listed at the end of the documentation to get the latest documentation.

Revision History

Verision	Initiated	Reviewed	Approved	Release Date
Va-4	Zore.Zhao	Kelly.Cao		2009-12-29

Notice:

Eoptolink reserves the right to make changes or discontinue any product or service identified in this publication, without notice, in order to improve design and/or performance. Applications that are described herein for any of the products are for illustrative purposes only. Eoptolink makes no representation or warranty that such applications will be suitable for the specified use without further testing or modification.

Contact:

Add: Floor 5, Building 2, No. 21 Gaopeng Avenue, High-Tech District, CHENGDU, SICHUAN 610041 P.R.
CHINA

Tel: (+86) 028-85122709 ext 816 & 809

Fax: (+86) 028-85121912

Postal: 610041

E-mail:sales@eoptolink.com

<http://www.eoptolink.com>