

## GDLR-5XXXXX

### 1550nm MQW-DFB Laser Diode Receptacle Module



#### Features

- ◆ Coaxial Package
- ◆ InGaAsP/InP MQW-DFB laser Diode
- ◆ Data rate up to 2.5Gbps
- ◆ Low threshold, high slope efficiency and high output power LD
- ◆ Maximum Soldering Temperature/Time: 260□/10s
- ◆ Operating Case temperature: -40C to +85C
- ◆ RoHS6 Compliant Products Available

#### Applications

- ◆ Optical Digital Transmission System
- ◆ Test Equipments

#### General

GDLR-5XXXXX Series are 1550nm InGaAsP/InP MQW-DFB laser diode modules designed for fiber communication systems. These modules are transmitter optical sub-assembly with low threshold current and high performance at high temperature, which are ideally suitable for long reach applications.

A laser diode is mounted into a coaxial package integrated with a single-mode fiber-stub, an isolator and an InGaAs monitor PD.

#### Ordering information (Standard version <sup>\*Note1</sup>)

Part No.	Package series	Pin Type	Isolator	Connector	Data rate
GDLR-5105A2	A	LD-Pin-2	N=None	FC-A	1.25Gbps
GDLR-5110B2G	B	LD-Pin-2	Single Stage	FC-B	1.25Gbps
GDLR-5220C1G	C	LD-Pin-1	Single Stage	FC-C	2.5Gbps
GDLR-5110D1G	D	LD-Pin-1	Single Stage	FC-D	1.25Gbps
GDLR-5120E2G	E	LD-Pin-2	Single Stage	ST	1.25Gbps
GDLR-5210F2	F	LD-Pin-2	N=None	SC	2.5Gbps
GDLR-5220F1G	F	LD-Pin-1	Single Stage	SC	2.5Gbps

\*Note1: For more ordering information, please refer the nomenclature and contact EPOTOLINK sales.

## Absolute maximum ratings<sup>\*Note2</sup>

Parameter	Symbol	Ratings	Unit
Storage temperature	Tstg	-40~+100	□
Operating case temperature	Top	-40~+85	□
Forward current (LD)	IFD	150	mA
Reverse voltage (LD)	VrL	2	V
Reverse voltage (PD)	VrP	20	V
Reverse current (PD)	IrP	2	mA
Soldering temperature (<10s)	Stemp	260	□

\*Note2: Exceeding any one of these values may destroy the device permanently.

## Electrical and optical characteristics<sup>\*Note3</sup>

(Po=1.5mW, SMF, Tc=+25°C, unless otherwise noted.)

Parameter	Symbol	Condition	Min	Typ	Max	Unit
Threshold current	Ith	CW	—	8	15	mA
Fiber Coupling Power	Pf	CW, If=Ith+20mA	1	1.5	2.8	mW
Operating voltage	Vf	CW, Tc=-40~+85□	—	1.2	1.6	V
Slope Efficiency	Se	CW, Average(Ith to Ith+20mA)	0.05	0.14	-	mW/mA
Peak wavelength	λp	CW	1540	1550	1565	nm
		CW, Tc=-40~+85°C	1530		1575	
Side mode suppression ratio	SMSR	CW, Tc=-40~+85°C	35	40		dB
Rise time	tr	Ib=Ith, 20-80%	—		0.2	ns
Fall time	tf	Ib=Ith, 80-20%	—	0.15	0.2	ns
Tracking error	ΔPf	(@Pf=0.16mW(25°C)) CW, Tc=-40~+85°C	-1.5	—	1.5	dB
Monitor current	Im	CW, VrP=5V, Tc=-40~+85°C	50	500	900	uA
Monitor dark current	Id	VrP=5V	—	—	100	nA
Monitor capacitance	C	VrP=5V, f=1MHz	—	10	20	pF
Connector repeatability	—		-1	—	1	dB
Optical Isolation	—	Single Stage	30			dB
		Dual Stage	40			

\*Note3: Under normal condition, when the threshold current plus 20mA, the output power is up 2.8mW; And when the threshold current plus 30mA, the output power is more than 3mW.

Eoptolink Technology Co. Ltd.

Package dimension

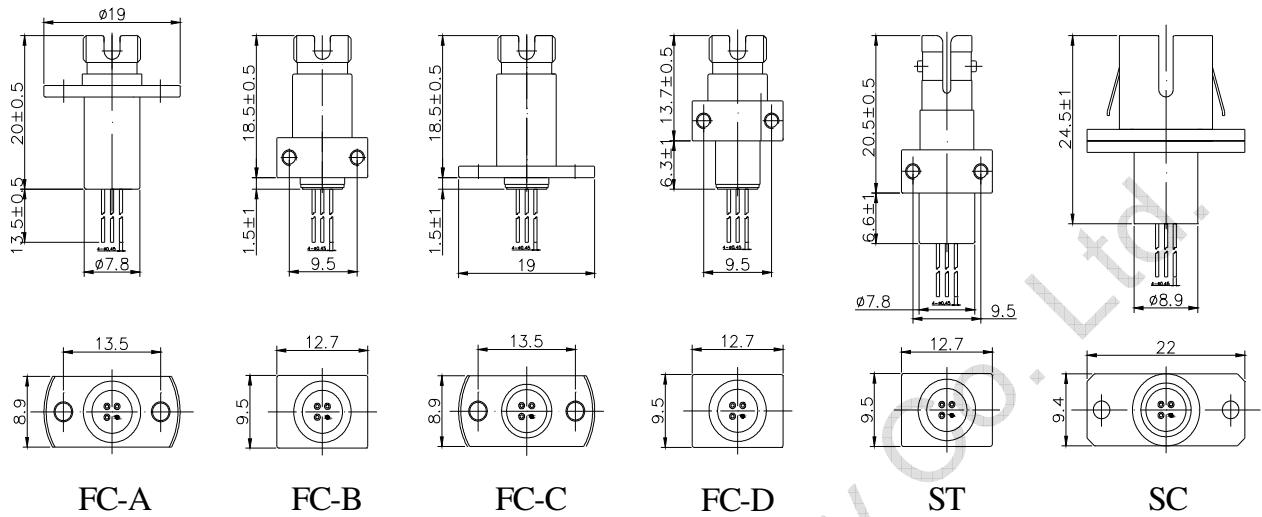

The direction of fix card

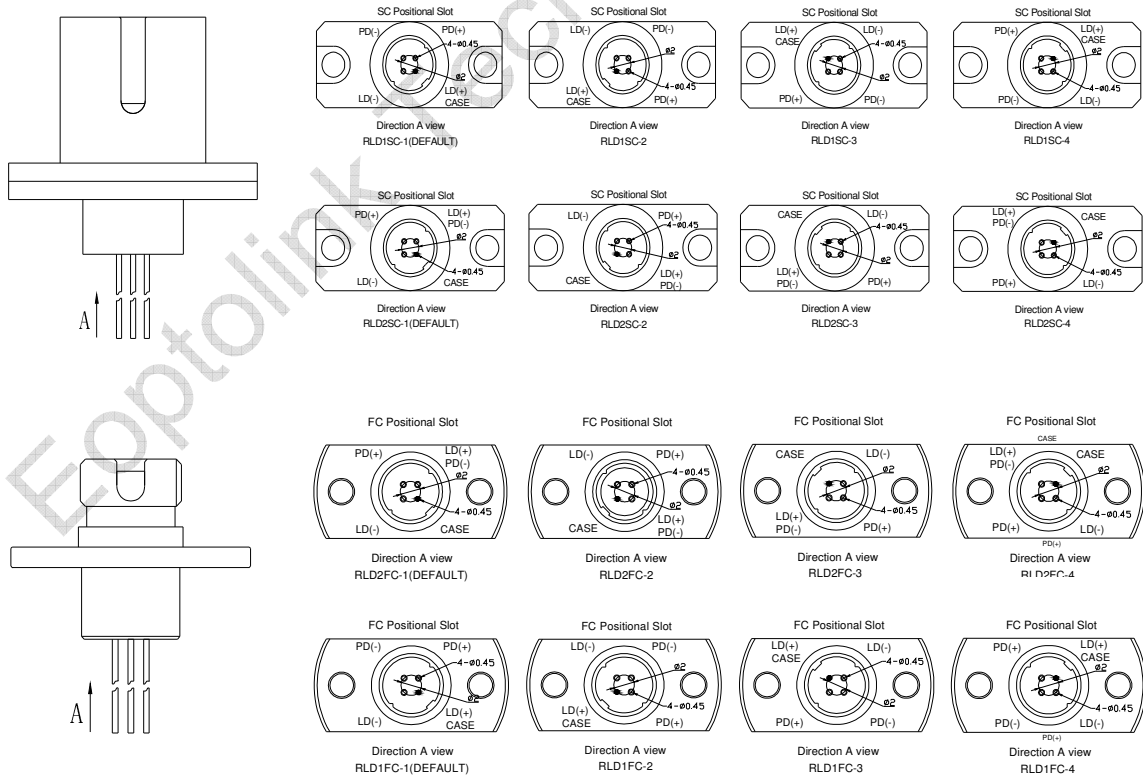

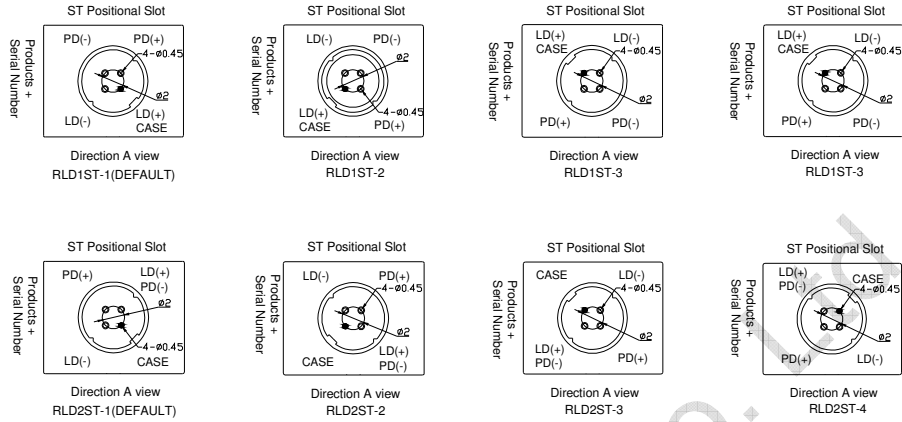
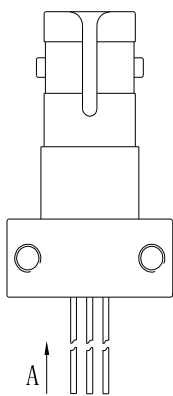

## Nomenclature of assembly direction\*Note4

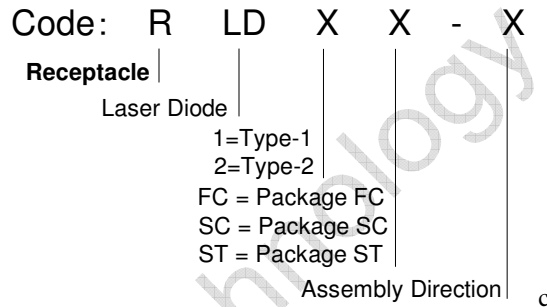

\*Note4: Please designate the code of assembly direction.

## Pin Assignment

TYPE: 1

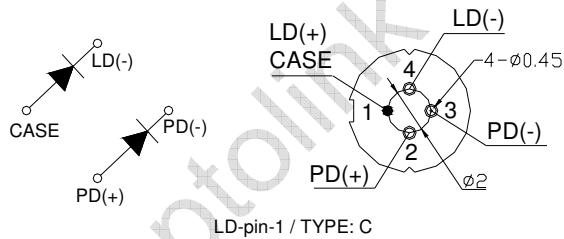

TYPE: 2

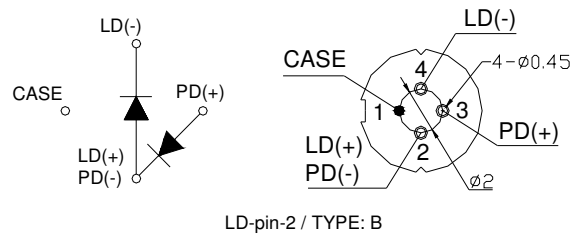

## Nomenclature

G D L R - 5 □ □ □ □ □ □  
A B C D E F

Order	Parameter	Detailed Description					
A	Center Wavelength	5=1550					
B	Data rate	1=1.25Gbps			2=2.5Gbps		
C	Power	05=0.3-0.8mW	10=0.8-1.8 mW		20=1.8-2.8 mW		
D	Package series	A=FC-A	B=FC-B	C=FC-C	D=FC-D	E=ST	F=SC

E	Pin Type	1=LD-pin-1		2=LD-pin-2	
F	Isolator	N=None	G= Single Stage		G2=Dual Stage

### Precaution

- (1) The modules should be handled in the same manner as ordinary semiconductor devices to prevent the electro-static damages. For safe keeping and carrying, the modules should be packaged with ESD proof material. To assemble the modules on PCB, the workbench, the soldering iron and the human body should be grounded.
- (2) Please pay special attention to the atmosphere condition because the dew on the module may cause some electrical damages.
- (3) Under such a strong vibration environment as in automobile, the performance and reliability are not guaranteed.

### Obtaining Document

You can visit our website:

<http://www.eoptolink.com>

Or contact Eoptolink Technology Inc., Ltd. listed at the end of the documentation to get the latest documentation.

### Revision History

Version	Initiated	Reviewed	Approved	Release Date
Va-4	Zore.Zhao	Kelly.Cao		2009-11-26

### Notice:

Eoptolink reserves the right to make changes or discontinue any product or service identified in this publication, without notice, in order to improve design and/or performance. Applications that are described herein for any of the products are for illustrative purposes only. Eoptolink makes no representation or warranty that such applications will be suitable for the specified use without further testing or modification.

### Contact:

Add: Floor 5, Building 2, No. 21 Gaopeng Avenue, High-Tech District, CHENGDU, SICHUAN 610041 P.R.  
CHINA

Tel: (+86) 028-85122709 ext 816 & 809

Fax: (+86) 028-85121912

Postal: 610041

E-mail:sales@eoptolink.com

<http://www.eoptolink.com>