

EOLF-1512-X Series

**Single Mode 1550nm 1.25G/1.063G for GBE/FC
Duplex SFF Transceiver
RoHS6 Compliant**

Features

- ◆ Duplex LC Single-Mode Transceiver
- ◆ Operating Data Rate up to 1.25Gbps
- ◆ 50km with 9/125µm SMF
 - 80km with 9/125µm SMF
 - 120km with 9/125µm SMF
 - 160km with 9/125µm SMF
- ◆ Single 3.3V Power supply
- ◆ LVPECL Signal Input/Output
- ◆ LVTTTL Transmitter Disable Input
- ◆ LVPECL Signal Detect Output
- ◆ Small Form Factor 2X5 pin Package
- ◆ Class 1 FDA and IEC60825-1 Laser Safety Compliant
- ◆ Operating Case Temperature
 - Standard: 0°C~+70°C
 - Industrial: -40°C~+85°C



Applications

- ◆ Fast Ethernet
- ◆ SONET/SDH Equipment Interconnect
- ◆ Fiber Channel Links
- ◆ Other Optical Link

Ordering Information

Part No.	Data Rate	Fiber	Distance	Temp.	Input/output
EOLF-1512-50 ^{*(note1)}	1.25Gbps	SMF	50km	Standard	DC/DC
EOLF-1512-50I	1.25Gbps	SMF	50km	Industrial	DC/DC
EOLF-1512-80 ^{*(note1)}	1.25Gbps	SMF	80km	Standard	DC/DC
EOLF-1512-80I	1.25Gbps	SMF	80km	Industrial	DC/DC
EOLF-1512-B ^{*(note1)}	1.25Gbps	SMF	120km	Standard	DC/DC
EOLF-1512-BI	1.25Gbps	SMF	120km	Industrial	DC/DC
EOLF-1512-C ^{*(note1)}	1.25Gbps	SMF	160km	Standard	DC/DC
EOLF-1512-CI	1.25Gbps	SMF	160km	Industrial	DC/DC

Note1: Standard version, other ordering information in detail refers to the denominate rule on next page.

Nomenclature

EOLF - □□ -□- □□

C D F I J

No.	Parameter	Detailed Description	
A	F		
B	Blank		
C	Wavelength	13=1310nm, 15=1550nm, 16=CWDM	
D	Data Rate	03=155M, 06=1.25G, 12=1.063G/1.25G, 24=2.125G/2.488G/2.5G	
E	Blank		
F	Distance	XM=1~9km, SMF; XX=XXkm, SMF, X=0~9	
G	Blank		
H	Blank		
I	Form		
J	Temperature	Blank = 0 ~ 70□	I = -40 ~ +85□
K	Blank		
Option	Input/output & SD	Blank=Input: DC; Output: DC; SD-TTL (FC/GBE/2FC/OC48)	Blank=Input: DC; Output: DC; SD-PECL(OC-3/STM-4)
		1=Input: AC; Output: AC; SD-TTL (FC/GBE/2FC/OC48)	1=Input: AC; Output: AC; SD-PECL (OC-3/STM-4)
		2=Input: AC; Output: DC; SD-TTL (FC/GBE/2FC/OC48)	2=Input: AC; Output: DC; SD-PECL (OC-3/STM-4)

Regulatory Compliance

Feature	Standard	Performance
Electrostatic Discharge (ESD) to the Electrical Pins	MIL-STD-883G Method 3015.7	Class 1C (>1000 V)
Electrostatic Discharge to the enclosure	EN 55024:1998+A1+A2 IEC-61000-4-2 GR-1089-CORE	Compliant with standards
Electromagnetic Interference (EMI)	FCC Part 15 Class B EN55022:2006 CISPR 22B :2006 VCCI Class B	Compliant with standards Noise frequency range: 30MHz to 6GHz. Good system EMI design practice required to achieve Class B margins. System margins are dependent on customer host board and chassis design.
Immunity	EN 55024:1998+A1+A2 IEC 61000-4-3	Compliant with standards. 1KHz sine-wave, 80% AM, from

		80MHz to 1GHz. No effect on transmitter/receiver performance is detectable between these limits.
Laser Eye Safety	FDA 21CFR 1040.10 and 1040.11 EN (IEC) 60825-1:2007 EN (IEC) 60825-2:2004+A1	CDRH compliant and Class I laser product. TüV Certificate No. 50135086
Component Recognition	UL and CUL EN60950-1:2006	UL File E317337 TüV Certificate No. 50135086 (CB scheme)
RoHS6	2002/95/EC 4.1&4.2 2005/747/EC 5&7&13	Compliant with standards ^{*note2}

Note2: For update of the equipments and strict control of raw materials, EOPTOLINK has the ability to supply the customized products since Jan 1st, 2007, which meet the requirements of RoHS6 (Restrictions on use of certain Hazardous Substances) of European Union.

In light of item 5 in RoHS exemption list of RoHS Directive 2002/95/EC, Item 5: Lead in glass of cathode ray tubes, electronic components and fluorescent tubes.

In light of item 13 in RoHS exemption list of RoHS Directive 2005/747/EC, Item 13: Lead and cadmium in optical and filter glass. The three exemptions are being concerned for Eoptolink's transceivers, because Eoptolink's transceivers use glass, which may contain Pb, for components such as lenses, isolators, and other components.

Product Description

The EOLF-1512-X series single-mode transceiver is small form factor, low power, high performance module for duplex optical data communications such as GBE, FE, 100BASE-FX, SONET OC-3 / SDH STM-1 and OC-12 / STM-4. This module is designed for single-mode fiber and operates at a nominal wavelength of 1550nm.

The transmitter section uses a multiple quantum well laser and is a class 1 laser compliant according to International Safety Standard IEC-60825. The receiver section uses an integrated InGaAs detector preamplifier (IDP) mounted in an optical header and a limiting post-amplifier IC. A LVPECL logic interface simplifies interface to external circuitry.

Interface information

The Signal Detect (SD, active high), normal optical input of receiver represents to a logic "1" level, which means asserted.

The following versions are available:

1. AC/AC Transceiver

Tx and Rx are AC coupling. Tx has differential 100Ω load.

2. DC/DC Transceiver

Standard PECL inputs and outputs, Tx and Rx are DC coupling.

3. AC/DC Transceiver

Tx is AC coupled, Differential 100Ω load, Rx has standard PECL output and is DC coupling.

Absolute Maximum Ratings

Parameter	Symbol	Min.	Max.	Unit
Storage Temperature	Ts	-40	+85	°C
Supply Voltage	Vcc	-0.5	3.6	V
Operating Relative Humidity		-	95	%

*Exceeding any one of these values may destroy the device permanently.

Recommended Operating Conditions

Parameter	Symbol	Min.	Typical	Max.	Unit	
Operating Case Temperature	T _A	EOLF-1512-X	0		+70	°C
		EOLF-1512-XI	-40		+85	
Power Supply Voltage	Vcc	3.15	3.3	3.45	V	
Power Supply Current	Icc			300	mA	
Data Rate	GBE		1.25		Gbps	
	FC		1.063			

Performance Specifications - Electrical

Parameter	Symbol	Min.	Typ.	Max	Unit	Notes
Transmitter						
LVPECL Inputs(Differential)	V _{in}	400		2000	mVpp	AC Coupled Inputs ^{*(note3)}
Input Impedance (Differential)	Z _{in}	85	100	115	ohm	R _{in} > 100 kohm @ DC
TX_Dis	Disable	2		Vcc+0.3	V	
	Enable	0		0.8		
TX_FAULT	Fault	2		Vcc+0.3	V	
	Normal	0		0.5		
Receiver						
LVPECL Outputs (Differential)	V _{out}	400		2000	mVpp	AC Coupled Outputs ^{*(note3)}
Output Impedance (Differential)	Z _{out}	85	100	115	ohm	
RX_SD	Normal	-1.1		-0.74	V	
	SD	-2.0		-1.58	V	

Optical and Electrical Characteristics

(EOLF-1512-50 Series, 1550nm DFB & PIN/TIA)

Parameter	Symbol	Min.	Typical	Max.	Unit
9µm Core Diameter SMF			50		km
Data Rate		1.063	1.25		Gbps
Transmitter					

Centre Wavelength	λ_c	1520	1550	1580	nm
Spectral Width (-20dB)	$\Delta\lambda$			1	nm
Average Output Power ^{*(note4)}	Pout	-5		0	dBm
Extinction Ratio ^{*(note5)}	ER	9			dB
Rise/Fall Time(20%~80%)	tr/tf			2	ns
Total Jitter ^{*(note5)}	TJ			1	ns
Output Optical Eye	Telcordia GR-253-CORE and IUT-T G.957 Compliant ^{*(note7)}				
TX_Disable Assert Time	t_off			10	us
Receiver					
Center Wavelength	λ_c	1260		1600	nm
Receiver Sensitivity ^{*(note6)}	Pmin			-24	dBm
Receiver Overload	Pmax	-3			dBm
Return Loss		14			dB
SD De-Assert	SDD			-25	dBm
SD Assert	SDA	-45			dBm
SD Hysteresis ^{*(note8)}		0.5			dB

(EOLF-1512-80 Series, 1550nm DFB & PIN/TIA)

Parameter	Symbol	Min.	Typical	Max.	Unit
9 μ m Core Diameter SMF			80		km
Data Rate		1.063	1.25		Gbps
Transmitter					
Centre Wavelength	λ_c	1520	1550	1580	nm
Spectral Width (-20dB)	$\Delta\lambda$			1	nm
Average Output Power ^{*(note4)}	Pout	0		5	dBm
Extinction Ratio ^{*(note5)}	ER	9			dB
Rise/Fall Time(20%~80%)	tr/tf			2	ns
Total Jitter ^{*(note5)}	TJ			1	ns
Output Optical Eye	Telcordia GR-253-CORE and IUT-T G.957 Compliant ^{*(note7)}				
TX_Disable Assert Time	t_off			10	us
Receiver					
Center Wavelength	λ_c	1260		1600	nm
Receiver Sensitivity ^{*(note6)}	Pmin			-24	dBm
Receiver Overload	Pmax	-3			dBm
Return Loss		14			dB
SD De-Assert	SDD			-25	dBm
SD Assert	SDA	-45			dBm
SD Hysteresis ^{*(note8)}		0.5			dB

(EOLF-1512-B Series, 1550nm DFB & APD/TIA)

Parameter	Symbol	Min.	Typical	Max.	Unit
9 μ m Core Diameter SMF			120		km

Data Rate		1.063	1.25		Gbps
Transmitter					
Centre Wavelength	λ_c	1520	1550	1580	nm
Spectral Width (-20dB)	$\Delta\lambda$			1	nm
Average Output Power ^{*(note4)}	P _{out}	0		5	dBm
Extinction Ratio ^{*(note5)}	ER	9			dB
Rise/Fall Time(20%~80%)	tr/tf			2	ns
Total Jitter ^{*(note5)}	TJ			1	ns
Output Optical Eye	Telcordia GR-253-CORE and IUT-T G.957 Compliant ^{*(note7)}				
TX_Disable Assert Time	t _{off}			10	us
Receiver					
Center Wavelength	λ_c	1260		1600	nm
Receiver Sensitivity ^{*(note6)}	P _{min}			-30	dBm
Receiver Overload	P _{max}	-10			dBm
Return Loss		14			dB
SD De-Assert	SDD			-31	dBm
SD Assert	SDA	-45			dBm
SD Hysteresis ^{*(note8)}		0.5			dB

(EOLF-1512-C Series, 1550nm DFB & APD/TIA)

Parameter	Symbol	Min.	Typical	Max.	Unit
9µm Core Diameter SMF			160		km
Data Rate		1.063	1.25		Gbps
Transmitter					
Centre Wavelength	λ_c	1520	1550	1580	nm
Spectral Width (-20dB)	$\Delta\lambda$			1	nm
Average Output Power ^{*(note4)}	P _{out}	3		7	dBm
Extinction Ratio ^{*(note5)}	ER	9			dB
Rise/Fall Time(20%~80%)	tr/tf			2	ns
Total Jitter ^{*(note5)}	TJ			1	ns
Output Optical Eye	Telcordia GR-253-CORE and IUT-T G.957 Compliant ^{*(note7)}				
TX_Disable Assert Time	t _{off}			10	us
Receiver					
Center Wavelength	λ_c	1260		1600	nm
Receiver Sensitivity ^{*(note6)}	P _{min}			-33	dBm
Receiver Overload	P _{max}	-10			dBm
Return Loss		14			dB
SD De-Assert	SDD			-34	dBm
SD Assert	SDA	-45			dBm
SD Hysteresis ^{*(note8)}		0.5			dB

Note3: LVPECL logic, internally AC coupled.

Note4: Output is measured by coupling into a 9/125µm single-mode fiber.

Note5: Filtered, measured with a PRBS 2⁷-1 test pattern @1.25Gbps.

Note6: Minimum average optical power measured at BER less than 1E-12, with a 2⁷-1 PRBS and ER=9 dB.

Note7: Eye Pattern Mask

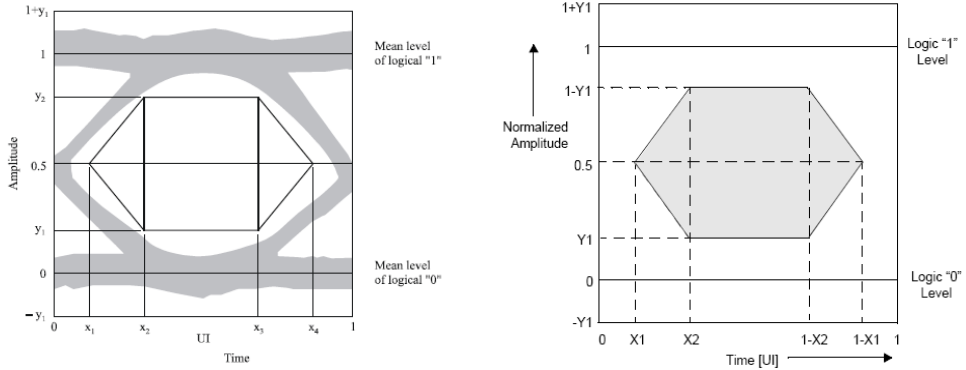

Note8: SD Hysteresis

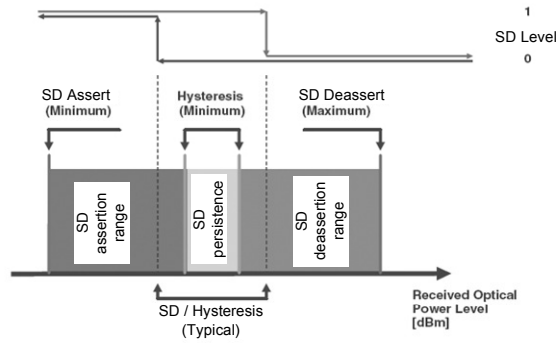

Functional Description of Transceiver

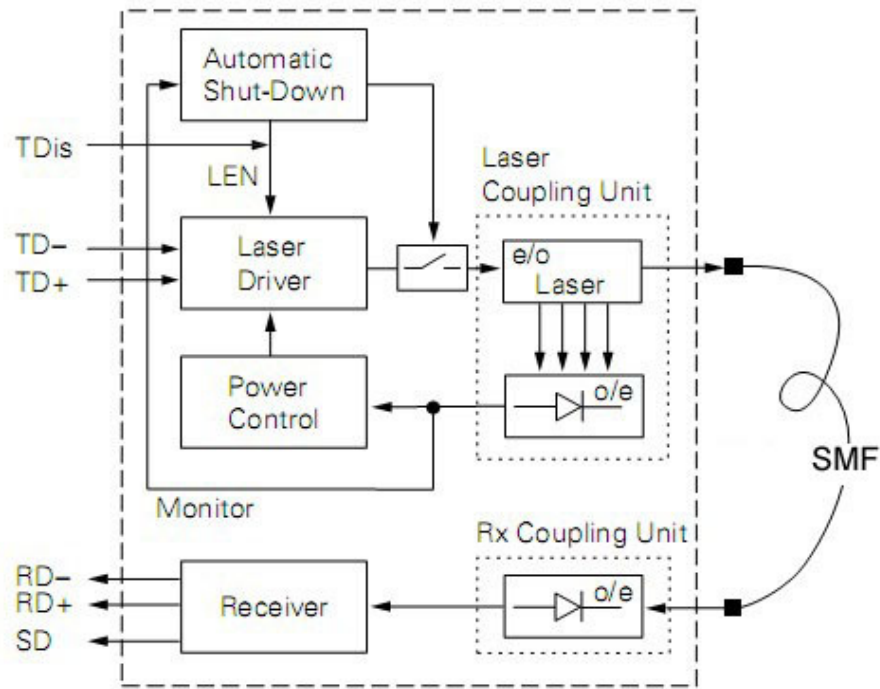

SFF Transceiver Electrical Pad Layout

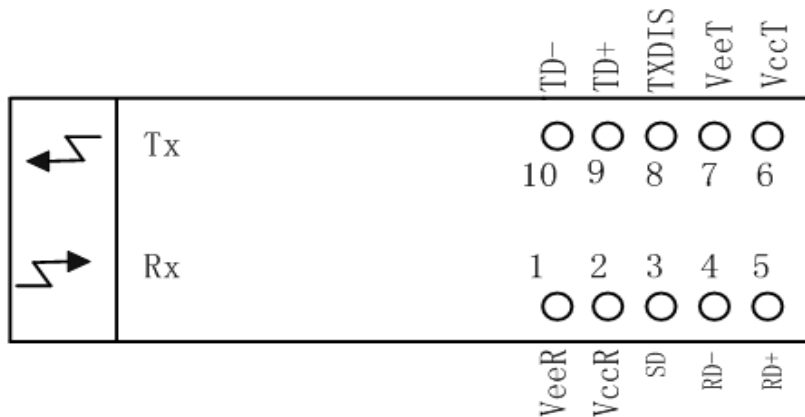

*Case isolated from circuit ground.

Pin Function Definitions

Pin No.	Name	Function
	MS	Mounting Studs, Case isolated from circuit ground
1	VeeR	Receiver Signal Ground
2	VccR	3.3V DC power for receiver section
3	SD	Signal Detect Output (LVPECL) "1" - "Signal valid", "0" - "Lose of signal"

4	RD-	Received Data Out Bar (LVPECL), without termination inside
5	RD+	Received Data Out (LVPECL), without termination inside
6	VccT	3.3V DC power for transmitter section
7	VeeT	Transmitter Signal Ground
8	TXDIS	Transmitter Disable (LVTTTL), "1" – Disable, "0" – Enable
9	TD+	Transmitter Data In (LVPECL), without termination inside
10	TD-	Transmitter Data In Bar (LVPECL), without termination inside

Recommend Circuit Schematic

AC/AC coupling

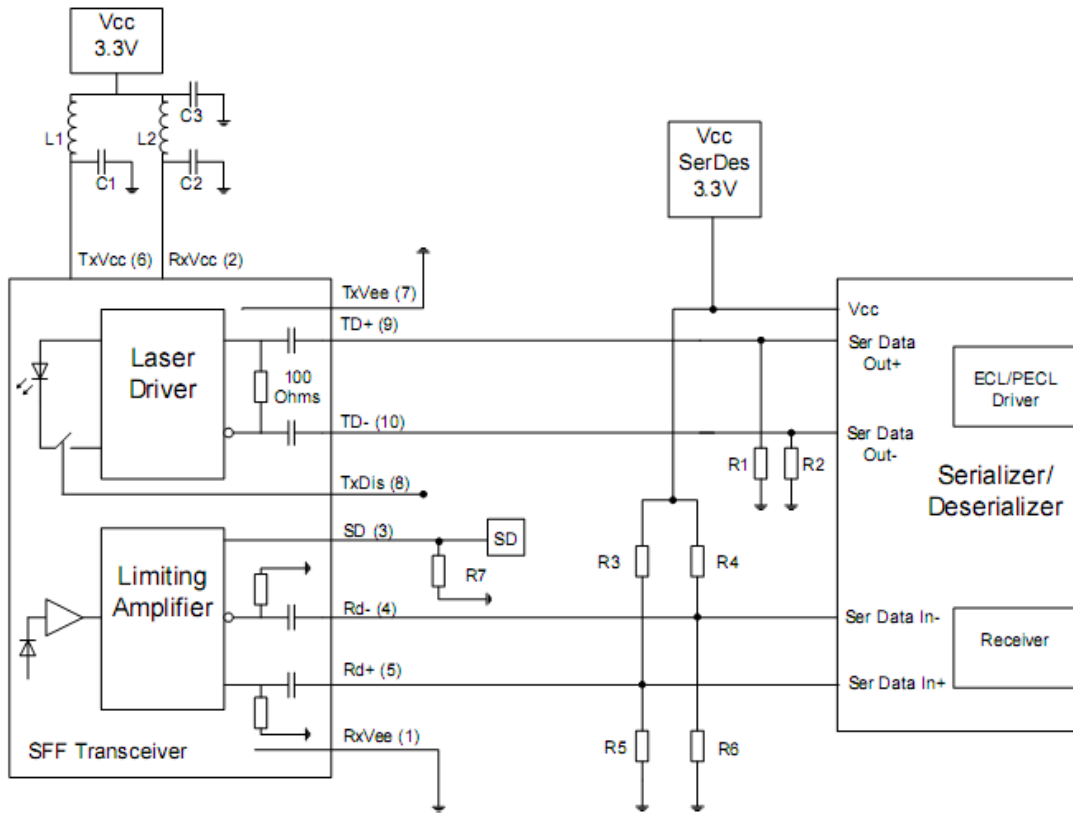

- L1, L2: 1...4.7 μ H
 - C1, C2, C3: 4.7...10 μ F
 - R1, R2: biasing of outputs depending on Serializer
 - R3, R4: 127 Ohms
 - R5, R6: 80 Ohms
 - R7: 510 Ohms for PECL signal detect, open for TTL
- Place R1/2/3/4/5/6 as close to SerDes chip as possible

DC/DC coupling

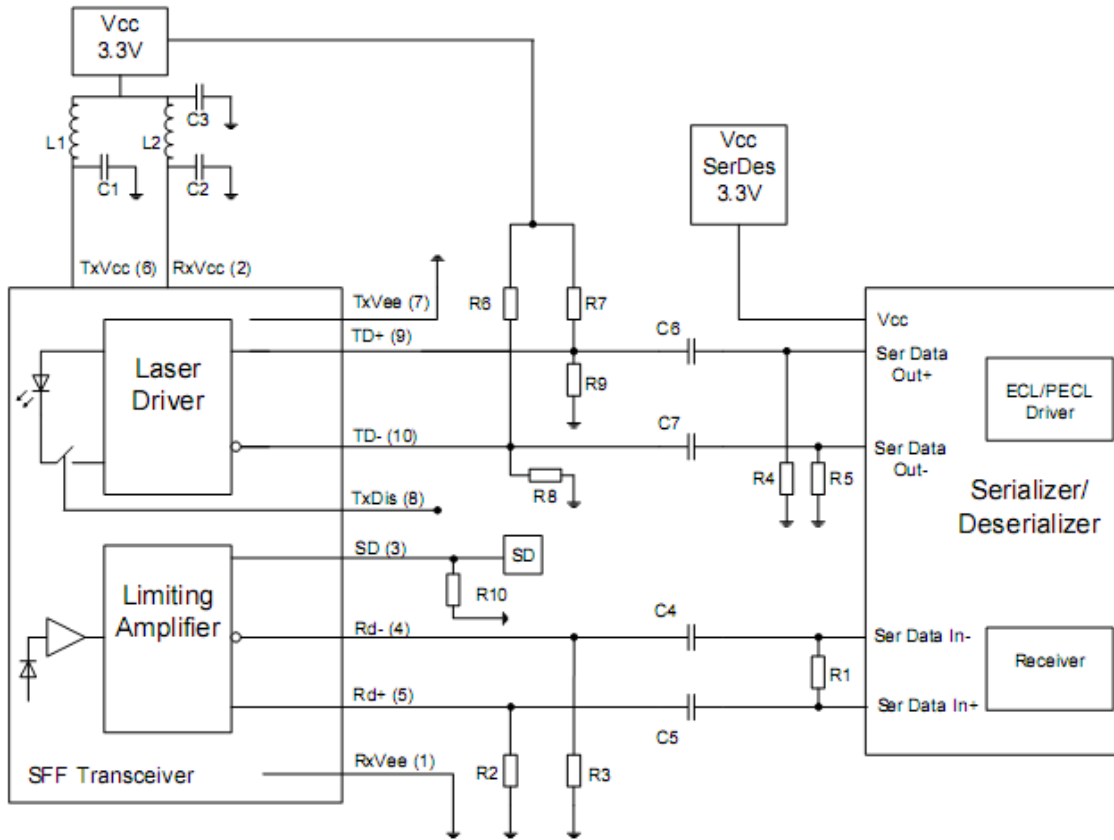

- L1, L2: 1...4.7 μ H
 - C1, C2, C3: 4.7...10 μ F
 - C4, C5, C6, C7: 100 nF
 - R1: 100 Ohms
 - R2, R3: 150 Ohms
 - R4, R5: biasing of outputs depending on Serializer
 - R6, R7: 127 Ohms
 - R8, R9: 80 Ohms
 - R10: 510 Ohms for PECL signal detect, open for TTL
- Place R1/4/5 as close to SerDes as possible
Place R2/3 as close to transceiver as possible

Mechanical Specifications

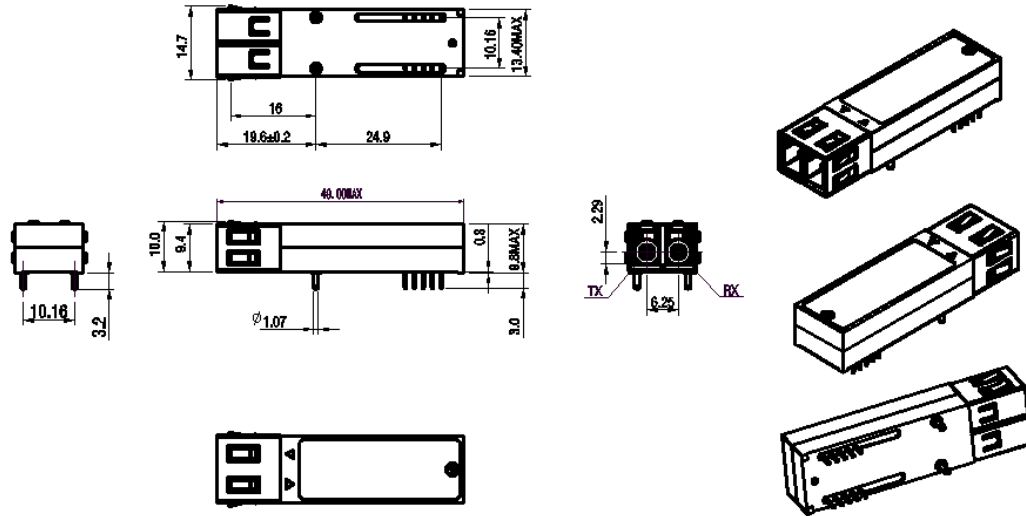

Class 1 Labels

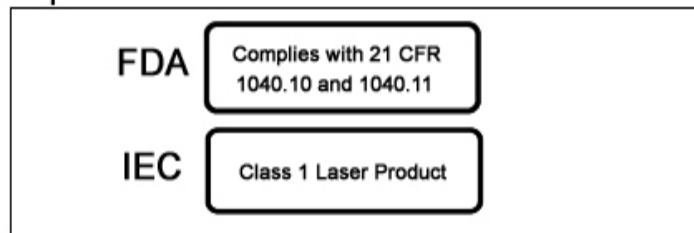

Laser Emission Data

Wavelength	1550nm
Total output power (as defined by FDA: 7mm aperture at 20cm distance)	<0.195mW
Total output power (as defined by IEC: 7mm aperture at 10cm distance)	<15.6mW
Beam divergence	12.5°

Laser Emission

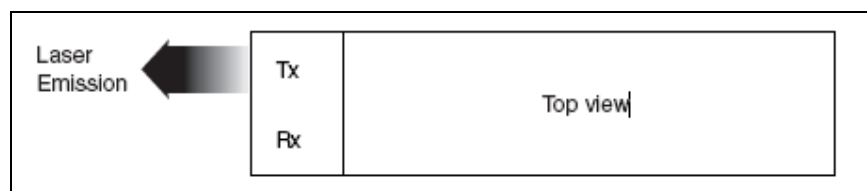

Obtaining Document

You can visit our website:

<http://www.eoptolink.com>

Or contact Eoptolink Technology Inc., Ltd. listed at the end of the documentation to get the latest document.

Revision History

Revision	Initiated	Reviewed	Approved	DCN	Release Date
V3.a	Cathy	Kelly		Released.	Mar 24, 2008

Notice:

Eoptolink reserves the right to make changes to or discontinue any optical link product or service identified in this publication, without notice, in order to improve design and/or performance. Applications that are described herein for any of the optical link products are for illustrative purposes only. Eoptolink makes no representation or warranty that such applications will be suitable for the specified use without further testing or modification.

Contact:

Add: Floor 5, Building 2, No. 21 Gaopeng Avenue, High-Tech District, CHENGDU, SICHUAN
610041 P.R. CHINA

Tel: (+86) 028-85122709 ext 816 & 809

Fax: (+86) 028-85121912

Postal: 610041

E-mail: sales@eoptolink.com

<http://www.eoptolink.com>