

EOLF-8524-02 Series

**Multi-Mode 850nm 2.5Gbps
Duplex SFF Transceiver
RoHS6 Compliant**



Features

- ◆ Duplex LC Multi-Mode Transceiver
- ◆ Operating Data Rate up to 2.5Gbps
- ◆ 850nm VCSEL Laser Transmitter
- ◆ 300m with 50/125μm MMF
150m with 62.5/125μm MMF
- ◆ Single 3.3V Power supply
- ◆ LVPECL Signal Input/Output
- ◆ LVTTL Transmitter Disable Input
- ◆ LVTTL Signal Detect Output
- ◆ Small Form Factor 2X5 pin Package
- ◆ Class 1 FDA and IEC60825-1 Laser Safety Compliant
- ◆ Operating Case Temperature
Standard: 0°C~+70°C

Applications

- ◆ SONET/SDH Equipment Interconnect
- ◆ Fiber Channel Links
- ◆ Gigabit Ethernet
- ◆ Other Optical Link

Ordering Information

Part No.	Data Rate	Fiber	Distance	Temp.	Input/output
EOLF-8524-02 ^{*(note1)}	2.5Gbps	MMF	300m	Standard	DC/DC
EOLF-8524-02I	2.5Gbps	MMF	300m	Industrial	DC/DC

*Note1:

Nomenclature

EOLF - □□ -□- □□

C D F I J

No.	Parameter	Detailed Description	
A	F		
B	Blank		
C	Wavelength	85=850nm, 13=1310nm, 15=1550nm, 16=CWDM	
D	Data Rate	03=155M, 06=622M, 12=1.063G/1.25G, 24=2.125G/2.488G/2.5G	
E	Blank		
F	Distance	XM=1~9km, MMF; XX=XXkm, SMF, X=0~9	
G	Blank		
H	Blank		
I	Form		
J	Temperature	Blank = 0 ~ 70□	I = -40 ~ +85□
K	Blank		
Option	Input/output & SD	Blank=Input: DC; Output: DC; SD-TTL (FC/GBE/2FC/OC48)	Blank=Input: DC; Output: DC; SD-PECL(OC-3/STM-4)
		1=Input: AC; Output: AC; SD-TTL (FC/GBE/2FC/OC48)	1=Input: AC; Output: AC; SD-PECL (OC-3/STM-4)
		2=Input: AC; Output: DC; SD-TTL (FC/GBE/2FC/OC48)	2=Input: AC; Output: DC; SD-PECL (OC-3/STM-4)

Regulatory Compliance

Feature	Standard	Performance
Electrostatic Discharge (ESD) to the Electrical Pins	MIL-STD-883G Method 3015.7	Class 1C (>1000 V)
Electrostatic Discharge to the enclosure	EN 55024:1998+A1+A2 IEC-61000-4-2 GR-1089-CORE	Compliant with standards
Electromagnetic Interference (EMI)	FCC Part 15 Class B EN55022:2006 CISPR 22B :2006 VCCI Class B	Compliant with standards Noise frequency range: 30MHz to 6GHz. Good system EMI design practice required to achieve Class B margins. System margins are dependent on customer host board and chassis design.
Immunity	EN 55024:1998+A1+A2	Compliant with standards. 1KHz

	IEC 61000-4-3	sine-wave, 80% AM, from 80MHz to 1GHz. No effect on transmitter/receiver performance is detectable between these limits.
Laser Eye Safety	FDA 21CFR 1040.10 and 1040.11 EN (IEC) 60825-1:2007 EN (IEC) 60825-2:2004+A1	CDRH compliant and Class I laser product. TüV Certificate No. 50135086
Component Recognition	UL and CUL EN60950-1:2006	UL File E317337 TüV Certificate No. 50135086 (CB scheme)
RoHS6	2002/95/EC 4.1&4.2 2005/747/EC 5&7&13	Compliant with standards ^{*note2}

Note2: For update of the equipments and strict control of raw materials, EOPTOLINK has the ability to supply the customized products since Jan 1st, 2007, which meet the requirements of RoHS6 (Restrictions on use of certain Hazardous Substances) of European Union.

In light of item 5 in RoHS exemption list of RoHS Directive 2002/95/EC, Item 5: Lead in glass of cathode ray tubes, electronic components and fluorescent tubes.

In light of item 13 in RoHS exemption list of RoHS Directive 2005/747/EC, Item 13: Lead and cadmium in optical and filter glass. The three exemptions are being concerned for Eoptolink's transceivers, because Eoptolink's transceivers use glass, which may contain Pb, for components such as lenses, isolators, and other components.

Product Description

The EOLF-8524-02 series multi-mode transceivers is small form factor, low power, high performance module for bi-directional serial optical data communications such as Gigabit Ethernet IEEE 802.3z 1000BASE-SX, SONET/SDH and Fiber Channel 2X/1X. This module is designed for multi-mode fiber and operates at a nominal wavelength of 850nm.

The transmitter section uses a multiple quantum well 850nm VCSEL and is a class 1 laser compliant according to International Safety Standard IEC-60825. The receiver section uses an integrated GaAs detector preamplifier (IDP) mounted in an optical header and a limiting post-amplifier IC. A LVPECL logic interface simplifies interface to external circuitry.

Interface information

The Signal Detect (SD, active high), normal optical input of receiver represents to a logic "1" level, which means asserted.

The following versions are available:

1. AC/AC Transceiver

Tx and Rx are AC coupling. Tx has differential 100Ω load.

2. DC/DC Transceiver

Standard PECL inputs and outputs, Tx and Rx are DC coupling.

3. AC/DC Transceiver

Tx is AC coupled, Differential 100Ω load, Rx has standard PECL output and is DC coupling.

Absolute Maximum Ratings

Parameter	Symbol	Min.	Max.	Unit
Storage Temperature	Ts	-40	+85	°C
Supply Voltage	Vcc	-0.5	6	V
Operating Relative Humidity		-	95	%
Soldering Temperature			260/10	□/s

*Exceeding any one of these values may destroy the device immediately.

Recommended Operating Conditions

Parameter	Symbol	Min.	Typical	Max.	Unit
Operating Case Temperature	T _A	EOLF-8524-02	0	+70	°C
		EOLF-8524-02I	-40	+85	
Power Supply Voltage	Vcc	3.15	3.3	3.47	V
Power Supply Current(DC)	Icc		160	200	mA
Power Supply Current(AC)			185	225	
Data Rate	OC-48		2.5		Gbps
	2XFC		2.125		

Performance Specifications - Electrical

Parameter	Symbol	Min.	Typ.	Max	Unit	Notes
Transmitter						
LVPECL Inputs(Differential)	Vin	400		2000	mVpp	AC Coupled Inputs*(note3)
Input Impedance (Differential)	Zin	85	100	115	ohm	Rin > 100 kohm @ DC
TX_Dis	Disable	2		Vcc+0.3	V	
	Enable	0		0.8		
TX_FAULT	Fault	2		Vcc+0.3	V	
	Normal	0		0.5		
Receiver						
LVPECL Outputs (Differential)	Vout	400		2000	mVpp	AC Coupled Outputs*(note3)
Output Impedance (Differential)	Zout	85	100	115	ohm	
RX_SD	Normal	-1.1		-0.74	V	
	SD	-2.0		-1.58	V	

Optical and Electrical Characteristics

Parameter	Symbol	Min.	Typical	Max.	Unit
50µm Core Diameter MMF			300		m
Data Rate			2.5		Gbps
Transmitter					
Centre Wavelength	λ_C	820	850	860	nm
Spectral Width (RMS)	$\Delta\lambda$			0.85	nm
Average Output Power ^{*(note4)}	P _{out}	-9		-4	dBm
Extinction Ratio ^{*(note5)}	ER	9			dB
Deterministic Jitter	DJ	-	-	80	ps
Random jitter	RJ	-	-	147	ps
Relative Intensity Noise	RIN	-	-	-117	dB/Hz
Coupled Power Ratio	CPR	9	-	-	dB
Output Optical Eye	IUT-T G.957 Compliant ^{*(note7)}				
TX_Disable Assert Time	t _{off}			10	us
Receiver					
Center Wavelength	λ_C	770		860	nm
Receiver Sensitivity ^{*(note6)}	P _{min}			-15	dBm
Minimum Input Power (Saturation0)	P _{MIN}	-15	-	-	dBm
Maximum Input Power (Saturation)	P _{MAX}	-3	-	-	dBm
SD De-Assert	SDD			-16	dBm
SD Assert	SDA	-35			dBm
LOS Hysteresis ^{*(note8)}		0.5			dB

Note3: LVPECL logic, internally AC coupled.

Note4: Output power is measured by coupling into a 50/125µm multi-mode fiber.

Note5: Filtered, measured with a PRBS 2²³-1 test pattern @2500Mbps.

Note6: Minimum average optical power measured at BER 1E-10, with a 2²³-1 PRBS and ER=9 dB.

Note7: Eye Pattern Mask

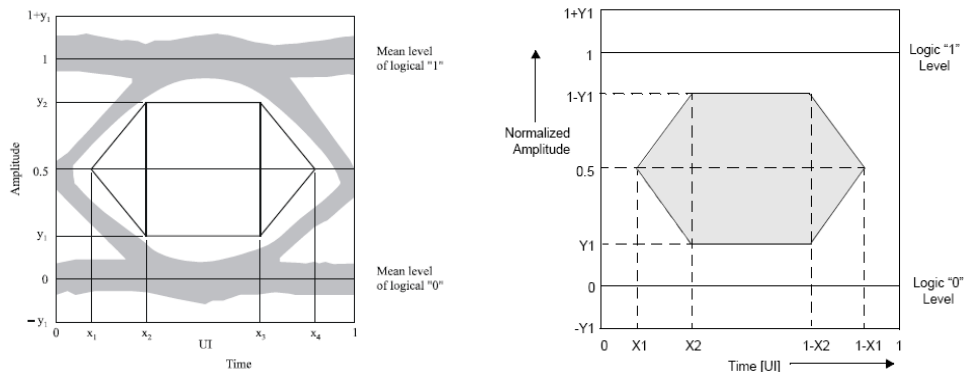

Note8: SD Hysteresis

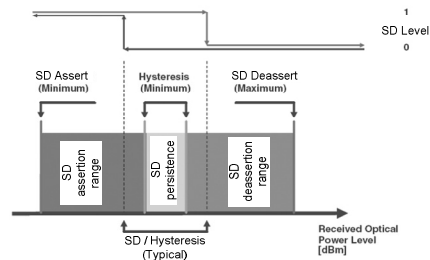

Functional Description of Transceiver

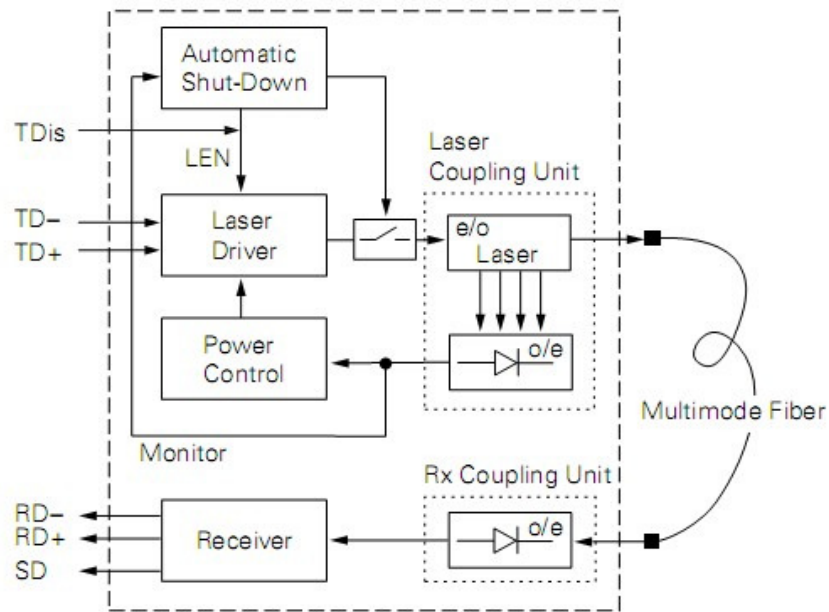

SFF Transceiver Electrical Pad Layout

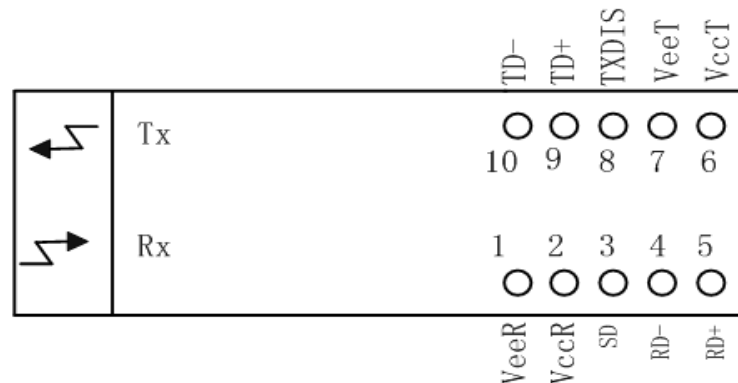

Case isolated from circuit ground.

Pin Function Definitions

Pin No.	Name	Function
---------	------	----------

	MS	Mounting Studs, Case isolated from circuit ground
1	VeeR	Receiver Signal Ground
2	VccR	3.3V DC power for receiver section
3	SD	Signal Detect Output (LVTTL) "1" - "Signal valid", "0" - "Lose of signal"
4	RD-	Received Data Out Bar (LVPECL), without termination inside
5	RD+	Received Data Out (LVPECL), without termination inside
6	VccT	3.3V DC power for transmitter section
7	VeeT	Transmitter Signal Ground
8	TXDIS	Transmitter Disable (LVTTL), "1" - Disable, "0" - Enable
9	TD+	Transmitter Data In (LVPECL), without termination inside
10	TD-	Transmitter Data In Bar (LVPECL), without termination inside

Recommend Circuit Schematic

AC/AC coupling

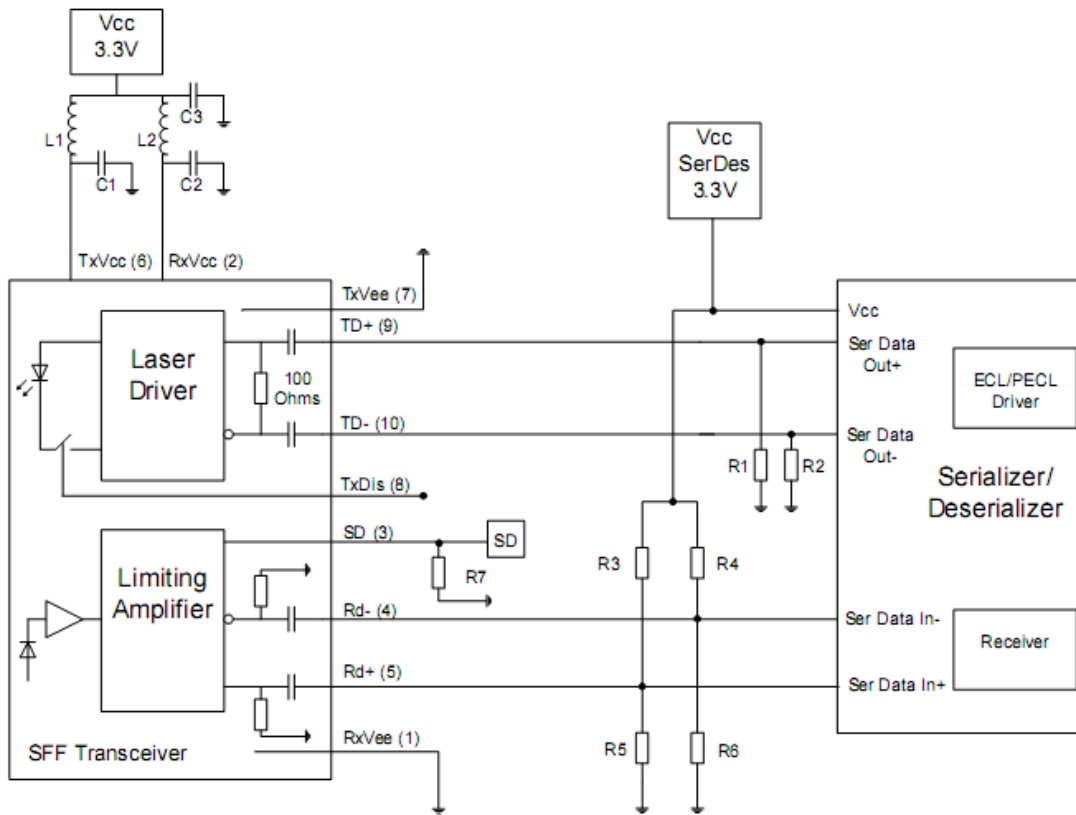

- L1, L2: 1...4.7 μ H
 - C1, C2, C3: 4.7...10 μ F
 - R1, R2: biasing of outputs depending on Serializer
 - R3, R4: 127 Ohms
 - R5, R6: 80 Ohms
 - R7: 510 Ohms for PECL signal detect, open for TTL
- Place R1/2/3/4/5/6 as close to SerDes chip as possible

DC/DC coupling

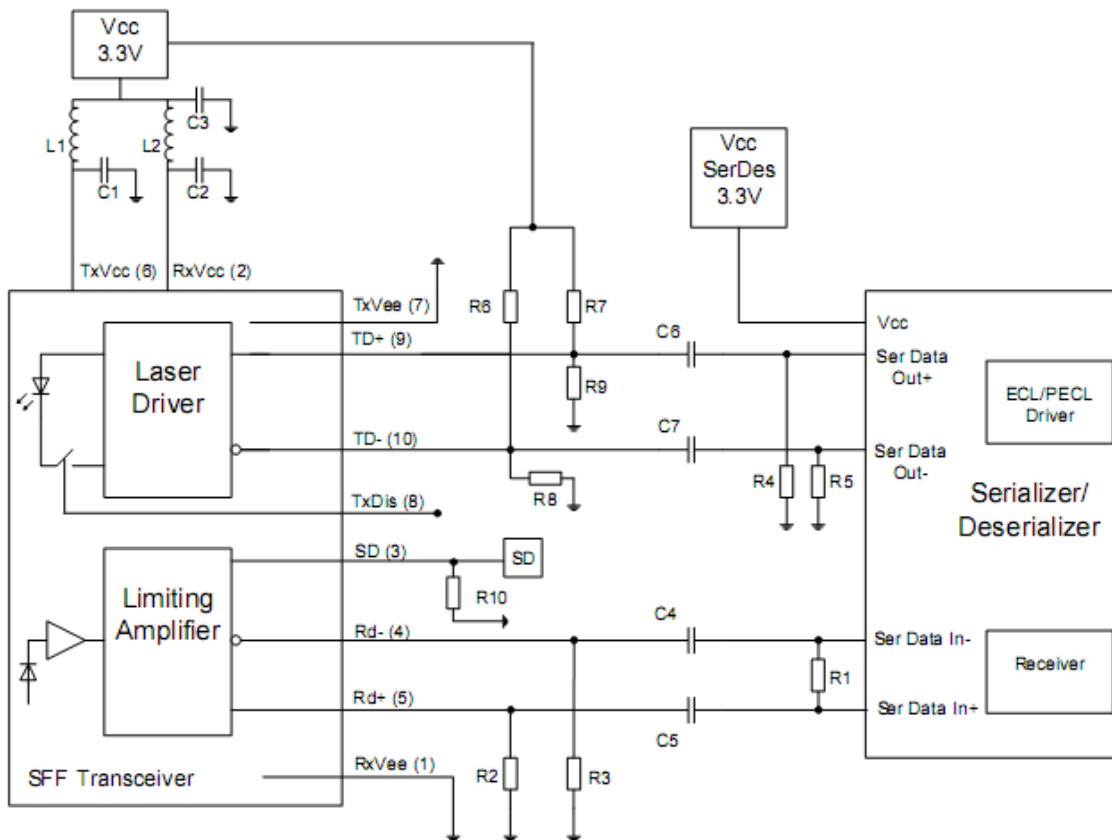

- L1, L2: 1...4.7 μ H
 - C1, C2, C3: 4.7...10 μ F
 - C4, C5, C6, C7: 100 nF
 - R1: 100 Ohms
 - R2, R3: 150 Ohms
 - R4, R5: biasing of outputs depending on Serializer
 - R6, R7: 127 Ohms
 - R8, R9: 80 Ohms
 - R10: 510 Ohms for PECL signal detect, open for TTL
- Place R1/4/5 as close to SerDes as possible
Place R2/3 as close to transceiver as possible

Mechanical Specifications

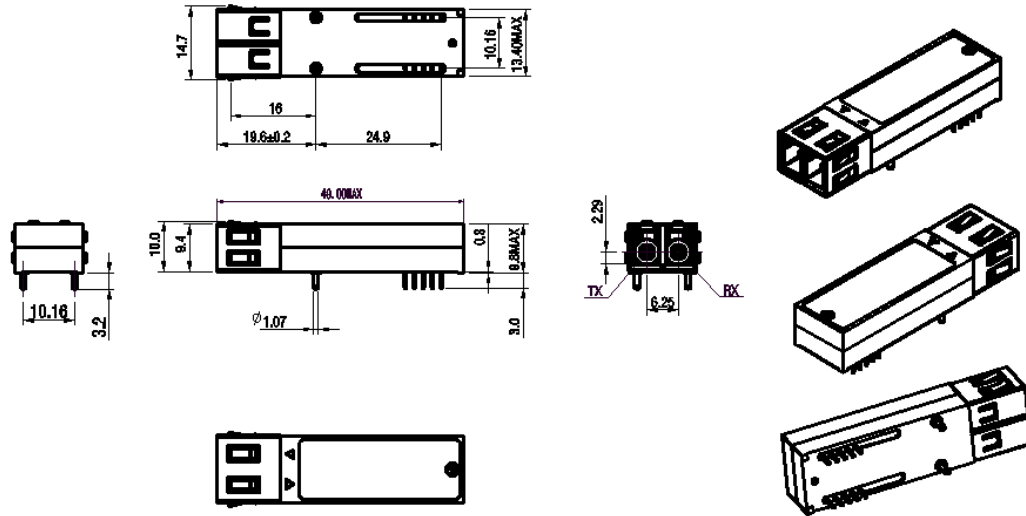

Class 1 Labels

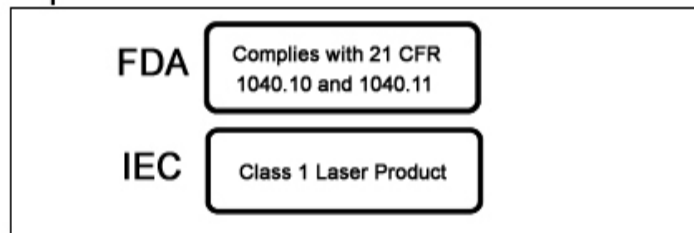

Laser Emission Data

Wavelength	850nm
Total output power (as defined by FDA: 7mm aperture at 20cm distance)	<0.076mW
Total output power (as defined by IEC: 7mm aperture at 10cm distance)	<0.778mW
Beam divergence	12°

Laser Emission

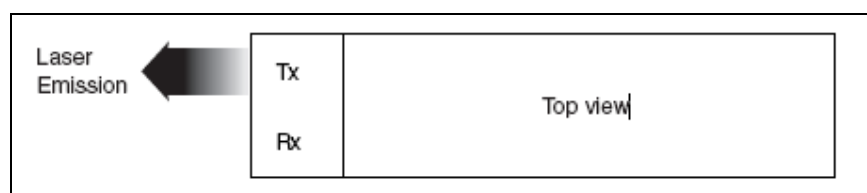

Obtaining Document

You can visit our website:

<http://www.eoptolink.com>

Or contact Eoptolink Technology Inc., Ltd. listed at the end of the documentation to get the latest document.

Revision History

Revision	Initiated	Reviewed	Approved	DCN	Release Date
V3.a	Cathy	Kelly		Released.	Mar 24, 2008

Notice:

Eoptolink reserves the right to make changes to or discontinue any optical link product or service identified in this publication, without notice, in order to improve design and/or performance. Applications that are described herein for any of the optical link products are for illustrative purposes only. Eoptolink makes no representation or warranty that such applications will be suitable for the specified use without further testing or modification.

Contact:

Add: Floor 5, Building 2, No. 21 Gaopeng Avenue, High-Tech District, CHENGDU, SICHUAN
610041 P.R. CHINA

Tel: (+86) 028-85122709 ext 816 & 809

Fax: (+86) 028-85121912

Postal: 610041

E-mail: sales@eoptolink.com

<http://www.eoptolink.com>