

## EOLF-1324-02 Series

**Single-Mode 1310nm 2.5Gbps SDH/SONET & 2.125Gbps 2xFC  
Duplex SFF Transceiver  
RoHS6 Compliant**

### Features

- ◆ Duplex LC Single-Mode Transceiver
- ◆ Operating Data Rate up to 2.5Gbps
- ◆ 1310nm FP Laser Transmitter
- ◆ 2km with 9/125μm SMF
- ◆ Single 3.3V Power supply
- ◆ LVPECL Signal Input/Output
- ◆ LVTTTL Transmitter Disable Input
- ◆ LVTTTL Signal Detect Output
- ◆ Small Form Factor 2X5 pin Package
- ◆ Class 1 FDA and IEC60825-1 Laser Safety Compliant
- ◆ Operating Case Temperature
  - Standard: 0°C~+70°C
  - Industrial:-40°C~+85°C



### Applications

- ◆ SONET/SDH Equipment Interconnect
- ◆ 2x Fiber Channel Links
- ◆ Other Optical Link

### Ordering Information

Part No.	Data Rate	Fiber	Distance	Temp.	Input/output
EOLF-1324-02 <sup>*(note1)</sup>	2.5Gbps	SMF	2km	Standard	DC/DC
EOLF-1324-02I	2.5Gbps	SMF	2km	Industrial	DC/DC

Note1: Standard version, other ordering information in detail refers to the denominate rule on next page.

## Nomenclature

**EOLF - □□ -□- □□**

**C D F I J**

No.	Parameter	Detailed Description	
A	F		
B	Blank		
C	Wavelength	85=850nm, 13=1310nm, 15=1550nm, 16=CWDM	
D	Data Rate	03=155M, 06=622M, 12=1.063G/1.25G, 24=2.125G/2.488G/2.5G	
E	Blank		
F	Distance	XM=1~9km, MMF; XX=XXkm, SMF, X=0~9	
G	Blank		
H	Blank		
I	Form		
J	Temperature	Blank = 0 ~ 70□	I = -40 ~ +85□
K	Blank		
Option	Input/output & SD	Blank=Input: DC; Output: DC; SD-TTL (FC/GBE/2FC/OC48)	Blank=Input: DC; Output: DC; SD-PECL(OC-3/STM-4)
		1=Input: AC; Output: AC; SD-TTL (FC/GBE/2FC/OC48)	1=Input: AC; Output: AC; SD-PECL (OC-3/STM-4)
		2=Input: AC; Output: DC; SD-TTL (FC/GBE/2FC/OC48)	2=Input: AC; Output: DC; SD-PECL (OC-3/STM-4)

## Regulatory Compliance

Feature	Standard	Performance
Electrostatic Discharge (ESD) to the Electrical Pins	MIL-STD-883G Method 3015.7	Class 1C (>1000 V)
Electrostatic Discharge to the enclosure	EN 55024:1998+A1+A2 IEC-61000-4-2 GR-1089-CORE	Compliant with standards
Electromagnetic Interference (EMI)	FCC Part 15 Class B EN55022:2006 CISPR 22B :2006 VCCI Class B	Compliant with standards Noise frequency range: 30MHz to 6GHz. Good system EMI design practice required to achieve Class B margins. System margins are dependent on customer host board and chassis design.
Immunity	EN 55024:1998+A1+A2	Compliant with standards. 1KHz

	IEC 61000-4-3	sine-wave, 80% AM, from 80MHz to 1GHz. No effect on transmitter/receiver performance is detectable between these limits.
Laser Eye Safety	FDA 21CFR 1040.10 and 1040.11 EN (IEC) 60825-1:2007 EN (IEC) 60825-2:2004+A1	CDRH compliant and Class I laser product. TüV Certificate No. 50135086
Component Recognition	UL and CUL EN60950-1:2006	UL File E317337 TüV Certificate No. 50135086 (CB scheme )
RoHS6	2002/95/EC 4.1&4.2 2005/747/EC 5&7&13	Compliant with standards <sup>*note2</sup>

Note2: For update of the equipments and strict control of raw materials, EOPTOLINK has the ability to supply the customized products since Jan 1st, 2007, which meet the requirements of RoHS6 (Restrictions on use of certain Hazardous Substances) of European Union.

In light of item 5 in RoHS exemption list of RoHS Directive 2002/95/EC, Item 5: Lead in glass of cathode ray tubes, electronic components and fluorescent tubes.

In light of item 13 in RoHS exemption list of RoHS Directive 2005/747/EC, Item 13: Lead and cadmium in optical and filter glass. The three exemptions are being concerned for Eoptolink's transceivers, because Eoptolink's transceivers use glass, which may contain Pb, for components such as lenses, isolators, and other components.

## Product Description

The EOLF-1324-02X series single mode transceiver is low power, high performance modules for bi-directional serial optical data communications such as SONET OC-48 LR / SDH STM-16. A guaranteed minimum optical link budget of 18 dB is offered.

The transmitter section uses a multiple quantum well laser and is a class 1 laser compliant according to International Safety Standard IEC-60825. The receiver section uses an integrated InGaAs detector preamplifier (IDP) mounted in an optical header and a limiting post-amplifier IC.

A PECL logic interface simplifies interface to external circuitry.

## Interface information

The Signal Detect (SD, active high), normal optical input of receiver represents to a logic "1" level, which means asserted.

The following versions are available:

1. DC/DC Transceiver

Standard PECL inputs and outputs, Tx and Rx are DC coupling

2. .AC/AC Transceiver

Tx and Rx are AC coupling. Tx has differential 100Ω load.

3. AC/DC Transceiver

Tx is AC coupled, Differential 100Ω load, Rx has standard PECL output and is DC coupling.

## Absolute Maximum Ratings

Parameter	Symbol	Min.	Max.	Unit
Storage Temperature	Ts	-40	+85	°C
Supply Voltage	Vcc	-0.5	3.6	V
Operating Relative Humidity		-	95	%

\*Exceeding any one of these values may destroy the device immediately.

## Recommended Operating Conditions

Parameter	Symbol	Min.	Typical	Max.	Unit	
Operating Case Temperature	T <sub>A</sub>	EOLF-1324-02X	0		+70	°C
		EOLF-1324-02IX	-40		+85	
Power Supply Voltage	Vcc	3.15	3.3	3.45	V	
Power Supply Current	Icc			300	mA	
Data Rate	OC-48/STM-16		2.5		Gbps	
	2XFC		2.125			

## Performance Specifications - Electrical

Parameter	Symbol	Min.	Typ.	Max	Unit	Notes
<b>Transmitter</b>						
LVPECL Inputs(Differential)	Vin	400		2000	mVpp	DC Coupled Inputs <sup>*(note3)</sup>
Input Impedance (Differential)	Zin	85	100	115	ohm	Rin > 100 kohm @ DC
TX_Dis	Disable	2		Vcc+0.3	V	
	Enable	0		0.8		
TX_FAULT	Fault	2		Vcc+0.3	V	
	Normal	0		0.5		
<b>Receiver</b>						
LVPECL Outputs (Differential)	Vout	400		2000	mVpp	DC Coupled Outputs <sup>*(note3)</sup>
Output Impedance (Differential)	Zout	85	100	115	ohm	
RX_SD	Normal	2		3.3	V	
	SD	0		0.8	V	

## Performance Specifications - Optical

(EOLF-1324-02 Series, FP and PIN)

Parameter	Symbol	Min.	Typical	Max.	Unit
Data Rate			2.5		Gbps
<b>Transmitter</b>					
Centre Wavelength	λ <sub>C</sub>	1270	1310	1350	nm

Spectral Width (RMS)	$\Delta\lambda$			4	nm
Average Output Power <sup>*(note4)</sup>	P <sub>out</sub>	-9.5		-3	dBm
Extinction Ratio <sup>*(note5)</sup>	ER	8.2			dB
Rise/Fall Time(20%~80%)	tr/tf			150	ps
Output Optical Eye	Telcordia GR-253-CORE and IUT-T G.957 Compliant <sup>*(note7)</sup>				
TX_Disable Assert Time	t <sub>off</sub>			10	us
<b>Receiver</b>					
Center Wavelength	$\lambda_c$	1260		1600	nm
Receiver Sensitivity <sup>*(note6)</sup>	P <sub>min</sub>			-18	dBm
Receiver Overload	P <sub>max</sub>	-5			dBm
SD De-Assert	SDD			-19	dBm
SD Assert	SDA	-35			dBm
LOS Hysteresis <sup>*(note8)</sup>		0.5			dB

Note3: LVPECL logic, internally DC coupled.

Note4: Output power is measured by coupling into a 9/125  $\mu\text{m}$  Single-mode fiber.

Note5: Filtered, measured with a PRBS  $2^{23}-1$  test pattern @2500Mbps.

Note6: Minimum average optical power measured at BER less than  $1\text{E}-12$ , with a  $2^{23}-1$  PRBS and ER=9 dB.

Note7: Eye Pattern Mask

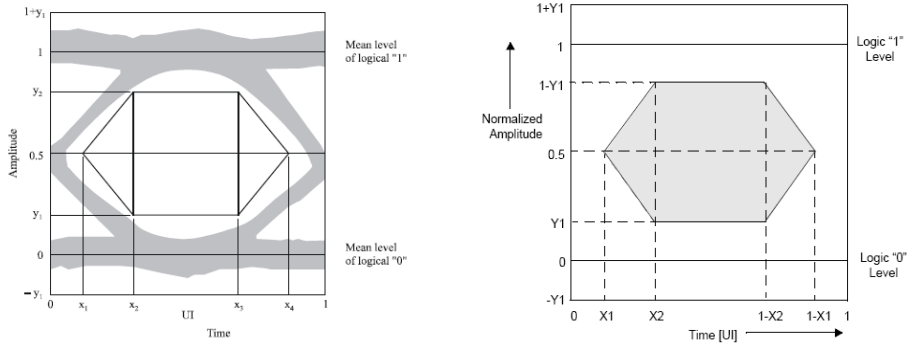

Note8: SD Hysteresis

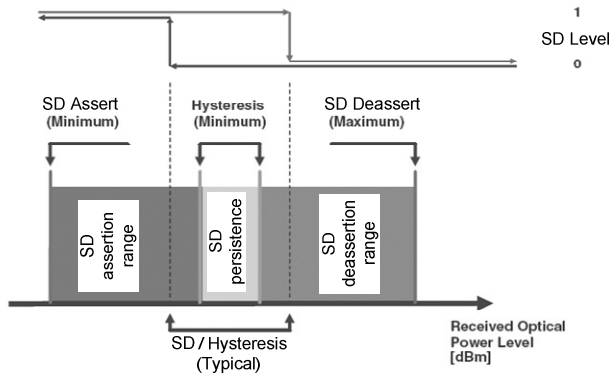

### Functional Description of Transceiver

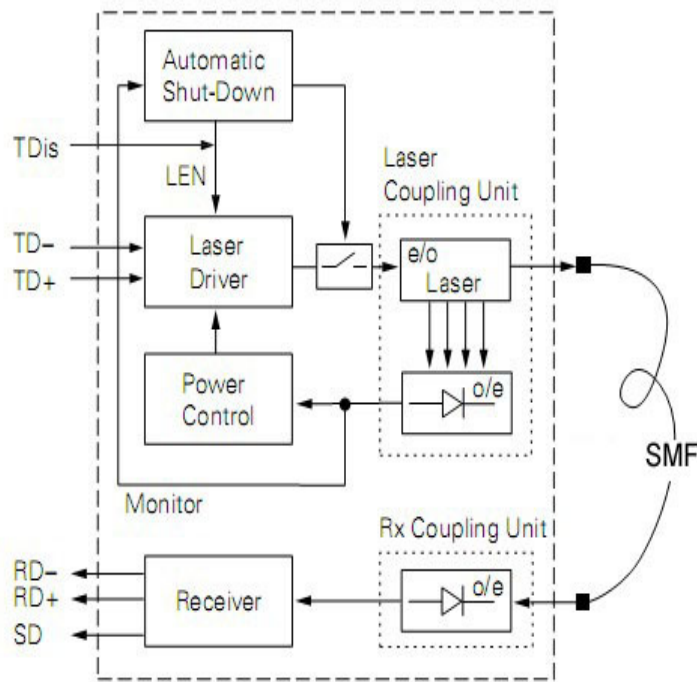

### SFF Transceiver Electrical Pad Layout

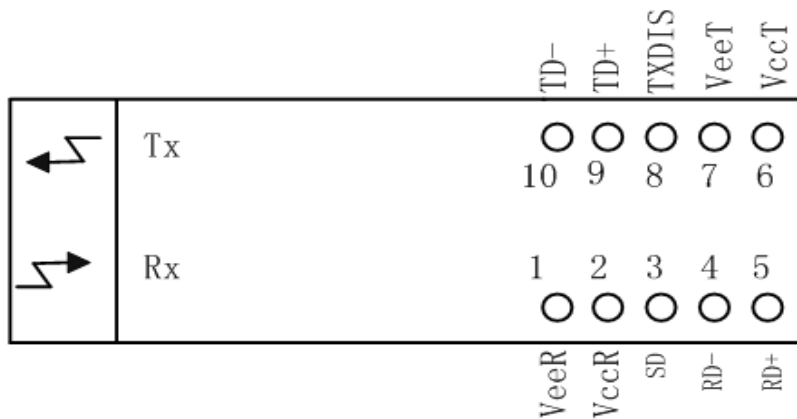

Case isolated from circuit ground.

### Pin Function Definitions

Pin No.	Name	Function
	MS	Mounting Studs, Case isolated from circuit ground
1	VeeR	Receiver Signal Ground
2	VccR	3.3V DC power for receiver section
3	SD	Signal Detect Output (LVTTTL) "1" - "Signal valid", "0" - "Lose of signal"

4	RD-	Received Data Out Bar (LVPECL), without termination inside
5	RD+	Received Data Out (LVPECL), without termination inside
6	VccT	3.3V DC power for transmitter section
7	VeeT	Transmitter Signal Ground
8	TXDIS	Transmitter Disable (LVTTTL), "1" – Disable, "0" – Enable
9	TD+	Transmitter Data In (LVPECL), without termination inside
10	TD-	Transmitter Data In Bar (LVPECL), without termination inside

## Recommend Circuit Schematic

### AC/AC coupling

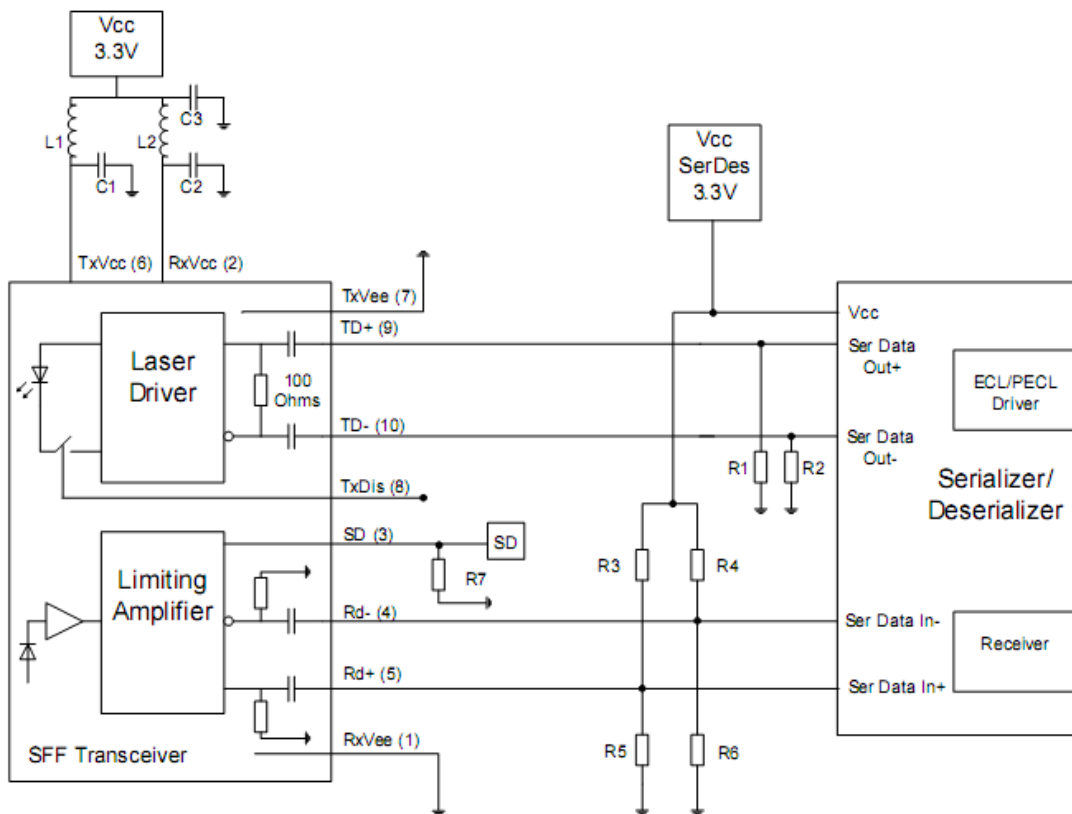

- L1, L2: 1...4.7  $\mu$ H
  - C1, C2, C3: 4.7...10  $\mu$ F
  - R1, R2: biasing of outputs depending on Serializer
  - R3, R4: 127 Ohms
  - R5, R6: 80 Ohms
  - R7: 510 Ohms for PECL signal detect, open for TTL
- Place R1/2/3/4/5/6 as close to SerDes chip as possible

DC/DC coupling

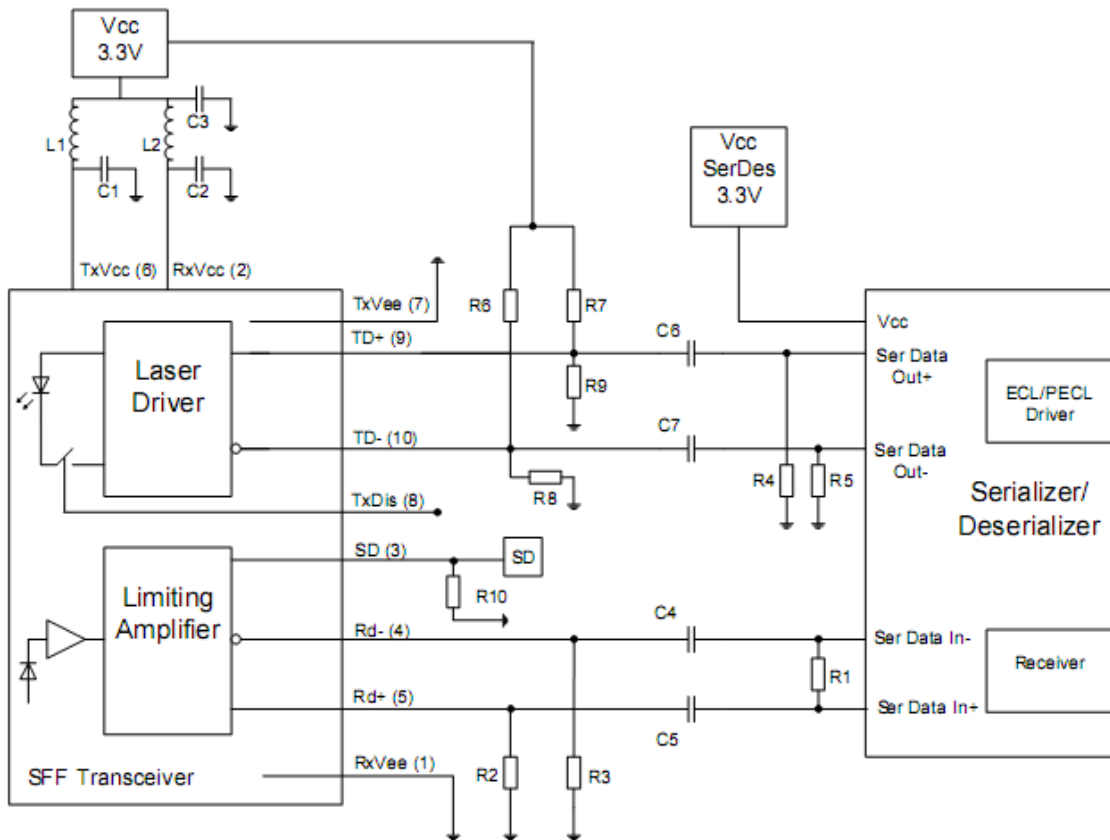

- L1, L2: 1...4.7  $\mu$ H
  - C1, C2, C3: 4.7...10  $\mu$ F
  - C4, C5, C6, C7: 100 nF
  - R1: 100 Ohms
  - R2, R3: 150 Ohms
  - R4, R5: biasing of outputs depending on Serializer
  - R6, R7: 127 Ohms
  - R8, R9: 80 Ohms
  - R10: 510 Ohms for PECL signal detect, open for TTL
- Place R1/4/5 as close to SerDes as possible  
Place R2/3 as close to transceiver as possible

Mechanical Specifications

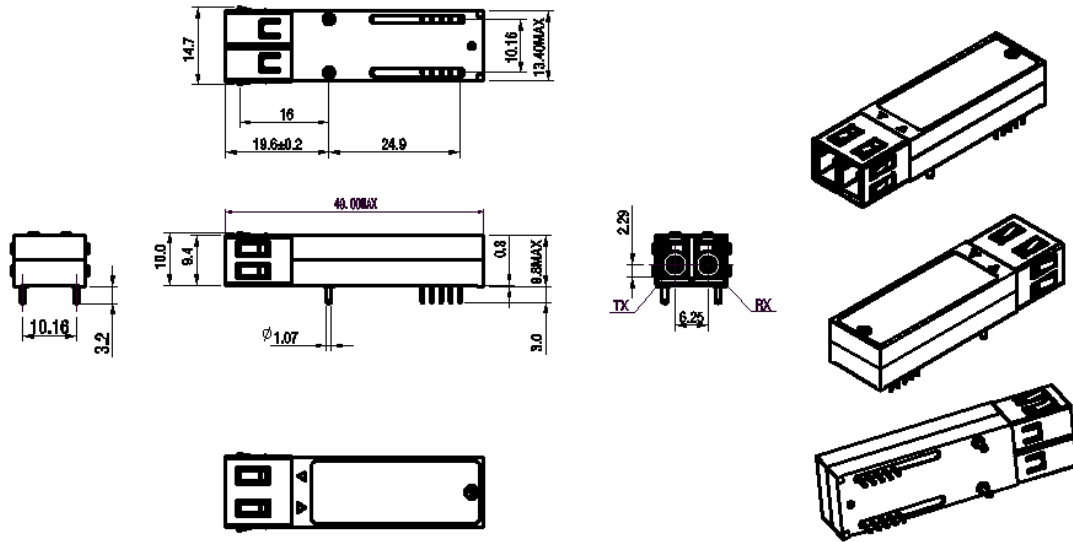

Class 1 Labels

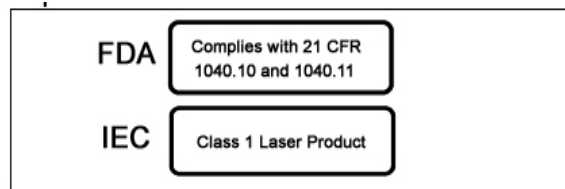

Laser Emission Data

Wavelength	1310nm
Total output power (as defined by FDA: 7 mm aperture at 20 cm distance)	<0.195mW
Total output power (as defined by IEC: 7 mm aperture at 10 cm distance)	<15.6mW
Beam divergence	12.5°

Laser Emission

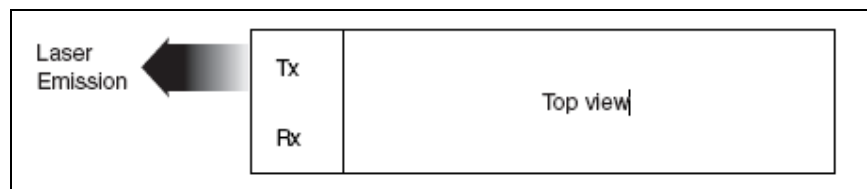

## Obtaining Document

You can visit our website:

<http://www.eoptolink.com>

Or contact Eoptolink Technology Inc., Ltd. listed at the end of the documentation to get the latest documents.

## Revision History

Revision	Initiated	Reviewed	Approved	DCN	Release Date
V3.a	Cathy	Kelly		Released.	Mar 24, 2008

## Notice:

Eoptolink reserves the right to make changes to or discontinue any optical link product or service identified in this publication, without notice, in order to improve design and/or performance. Applications that are described herein for any of the optical link products are for illustrative purposes only. Eoptolink makes no representation or warranty that such applications will be suitable for the specified use without further testing or modification.

## Contact:

Add: Floor 5, Building 2, No. 21 Gaopeng Avenue, High-Tech District, CHENGDU, SICHUAN  
610041 P.R. CHINA

Tel: (+86) 028-85122709 ext 816 & 809

Fax: (+86) 028-85121912

Postal: 610041

E-mail: sales@eoptolink.com

<http://www.eoptolink.com>