

EOLF-1348-X Series

**Single-Mode 1310nm 4.25Gbps
Duplex SFF Transceiver
RoHS6 Compliant**



Features

- ◆ Duplex LC Single-Mode Transceiver
- ◆ Operating Data Rate up to 4.25Gbps
- ◆ 5km with 9/125μm SMF
 - 10km with 9/125μm SMF
 - 20km with 9/125μm SMF
- ◆ Single 3.3V Power supply
- ◆ LVPECL Signal Input/Output
- ◆ LVTTTL Transmitter Disable Input
- ◆ LVTTTL Signal Detect Output
- ◆ Small Form Factor 2X5 pin Package
- ◆ Class 1 FDA and IEC60825-1 Laser Safety Compliant
- ◆ Operating Case Temperature
 - Standard: 0°C~+70°C
 - Industrial: -40°C~+85°C

Applications

- ◆ 4x2x1 Fiber Channel Links
- ◆ SONET/SDH Equipment Interconnect
- ◆ 1000BASE-SX Ethernet
- ◆ Other Optical Link

Ordering Information

Part No.	Data Rate	Fiber	Distance	Temp.	Input/output
EOLF-1348-05 ^{*(note1)}	4.25Gbps	SMF	5km	0°C~+70°C	AC/AC
EOLF-1348-05I	4.25Gbps	SMF	5km	-40°C~+85°C	AC/AC
EOLF-1348-10 ^{*(note1)}	4.25Gbps	SMF	10km	0°C~+70°C	AC/AC
EOLF-1348-10I	4.25Gbps	SMF	10km	-40°C~+85°C	AC/AC
EOLF-1348-20 ^{*(note1)}	4.25Gbps	SMF	20km	0°C~+70°C	AC/AC
EOLF-1348-20I	4.25Gbps	SMF	20km	-40°C~+85°C	AC/AC

Note1: Standard version.

Nomenclature

EOLF - □□ -□- □□

C D F I J

No.	Parameter	Detailed Description	
A	F		
B	Blank		
C	Wavelength	85=1310nm, 13=1310nm, 15=1550nm, 16=CWDM	
D	Data Rate	03=155M, 06=622M, 12=1.063G/1.25G, 24=2.125G/2.488G/2.5G, 48=4.25Gbps	
E	Blank		
F	Distance	02=850nm,MMF, XM=1~9km, MMF; XX=XX km, SMF, X=0~9	
G	Blank		
H	Blank		
I	Form	Blank = 2X5	
J	Temperature	Blank = 0 ~ 70□	I = -40 ~ +85□
K	Blank		
Option	Input/output & SD	Blank=Input: AC; Output: AC; SD-TTL (FC/GBE/2FC/OC48/4.25G)	Blank=Input: AC; Output: AC; SD-PECL(OC-3/STM-4)

Regulatory Compliance

Feature	Standard	Performance
Electrostatic Discharge (ESD) to the Electrical Pins	MIL-STD-883G Method 3015.7	Class 1C (>1000 V)
Electrostatic Discharge to the enclosure	EN 55024:1998+A1+A2 IEC-61000-4-2 GR-1089-CORE	Compliant with standards
Electromagnetic Interference (EMI)	FCC Part 15 Class B EN55022:2006 CISPR 22B :2006 VCCI Class B	Compliant with standards Noise frequency range: 30MHz to 6GHz. Good system EMI design practice required to achieve Class B margins. System margins are dependent on customer host board and chassis design.
Immunity	EN 55024:1998+A1+A2 IEC 61000-4-3	Compliant with standards. 1KHz sine-wave, 80% AM, from 80MHz to 1GHz. No effect on transmitter/receiver performance is detectable

		between these limits.
Laser Eye Safety	FDA 21CFR 1040.10 and 1040.11 EN (IEC) 60825-1:2007 EN (IEC) 60825-2:2004+A1	CDRH compliant and Class I laser product. TüV Certificate No. 50135086
Component Recognition	UL and CUL EN60950-1:2006	UL File E317337 TüV Certificate No. 50135086 (CB scheme)
RoHS6	2002/95/EC 4.1&4.2 2005/747/EC 5&7&13	Compliant with standards ^{*note2}

Note2: For update of the equipments and strict control of raw materials, EOPTOLINK has the ability to supply the customized products since Jan 1st, 2007, which meet the requirements of RoHS6 (Restrictions on use of certain Hazardous Substances) of European Union.

In light of item 5 in RoHS exemption list of RoHS Directive 2002/95/EC, Item 5: Lead in glass of cathode ray tubes, electronic components and fluorescent tubes.

In light of item 13 in RoHS exemption list of RoHS Directive 2005/747/EC, Item 13: Lead and cadmium in optical and filter glass. The three exemptions are being concerned for Eoptolink's transceivers, because Eoptolink's transceivers use glass, which may contain Pb, for components such as lenses, isolators, and other components.

Product Description

The EOLF-1348-X series single-mode transceiver is small form factor, low power, and high performance module for serial optical data communication, such as 1000BASE Ethernet, SONET/SDH and 4 X/2 X/1 X Fiber Channel. This module is designed for single-mode fiber and operates at a nominal wavelength of 1310nm.

The transmitter section uses a 1310nm multiple quantum well and is a class 1 laser compliant according to International Safety Standard IEC-60825. The receiver section uses an integrated GaAs detector preamplifier (IDP) mounted in an optical header and a limiting post-amplifier IC. A LVPECL logic interface simplifies interface to external circuitry.

Interface information

The Signal Detect (SD, active high), normal optical input of receiver represents to a logic "1" level, which means asserted.

The following versions are available:

1. AC/AC Transceiver

Tx and Rx are AC coupling. Tx has differential 100Ω load.

Absolute Maximum Ratings

Parameter	Symbol	Min.	Max.	Unit
Storage Temperature	Ts	-40	+85	°C
Supply Voltage	Vcc	-0.5	6	V
Operating Relative Humidity		-	95	%
Soldering Temperature			260/10	□/s

*Exceeding any one of these values may destroy the device immediately.

Recommended Operating Conditions

Parameter		Symbol	Min.	Typical	Max.	Unit
Operating Case Temperature	T _A	EOLF-1348-X	0		+70	°C
		EOLF-1348-XI	-40		+85	
Power Supply Voltage		V _{cc}	3.15	3.3	3.47	V
Power Supply Current(DC)		I _{cc}		160	200	mA
Date Rate	4XFC			4.25		Gbps

Performance Specifications - Electrical

Parameter		Symbol	Min.	Typ.	Max	Unit	Notes
Transmitter							
LVPECL Inputs(Differential)		V _{in}	400		2000	mVpp	AC Coupled Inputs*(note3)
Input Impedance (Differential)		Z _{in}	85	100	115	ohm	R _{in} > 100 kohm @ DC
TX_Dis	Disable		2		V _{cc} +0.3	V	
	Enable		0		0.8		
TX_FAULT	Fault		2		V _{cc} +0.3	V	
	Normal		0		0.5		
Receiver							
CML Outputs (Differential)		V _{out}	400		1600	mVpp	AC Coupled Outputs*(note3)
Output Impedance (Differential)		Z _{out}	85	100	115	ohm	
RX_SD	Normal		-1.1		-0.74	V	
	SD		-2.0		-1.58	V	

Performance Specifications –Optical
(EOLF-1348-05, 1310nm FP & PIN/TIA)

Parameter	Symbol	Min.	Typical	Max.	Unit
9µm Core Diameter SMF			5		km
Data Rate		1	4.25		Gbps
Transmitter					
Centre Wavelength	λ _C	1260	1310	1360	nm
Spectral Width (RMS)	Δλ			4	nm
Average Output Power*(note4)	P _{out}	-8		-3	dBm
Extinction Ratio*(note5)	ER	9			dB
Deterministic Jitter@4.25Gbps	D _J	-	-	28.2	ps
Relative Intensity Noise	RIN	-	-	-117	dB/Hz
Optical Rise/Fall Time (20%~80%)	tr/tf			90	ps
TX_Disable Assert Time	t _{off}			10	us

Eye diagram ^{*(note7)}		Compliant with ANSI FC-PI specification			
Receiver					
Center Wavelength	λ_C	1260		1600	nm
Receiver Sensitivity ^{*(note6)}	Pmin			-18	dBm
Maximum Input Power (Saturation)	Pmax	-3	-	-	dBm
SD De-Assert	SDD			-19	dBm
SD Assert	SDA	-35			dBm
SD Hysteresis ^{*(note8)}		0.5			dB

(EOLF-1348-10, 1310nm DFB & PIN/TIA)

Parameter	Symbol	Min.	Typical	Max.	Unit
9 μ m Core Diameter SMF			10		km
Data Rate		1	4.25		Gbps
Transmitter					
Centre Wavelength	λ_C	1260	1310	1360	nm
Spectral Width (-20dB)	$\Delta\lambda$			1	nm
Average Output Power ^{*(note4)}	Pout	-8		-3	dBm
Extinction Ratio ^{*(note5)}	ER	9			dB
Deterministic Jitter@4.25Gbps	D _J	-	-	28.2	ps
Relative Intensity Noise	RIN	-	-	-117	dB/Hz
Optical Rise/Fall Time (20%~80%)	tr/tf			90	ps
TX_Disable Assert Time	t_off			10	us
Eye diagram ^{*(note7)}		Compliant with ANSI FC-PI specification			
Receiver					
Center Wavelength	λ_C	1260		1600	nm
Receiver Sensitivity ^{*(note6)}	Pmin			-18	dBm
Maximum Input Power (Saturation)	Pmax	-3	-	-	dBm
SD De-Assert	SDD			-19	dBm
SD Assert	SDA	-35			dBm
SD Hysteresis ^{*(note8)}		0.5			dB

(EOLF-1348-20, 1310nm DFB & PIN/TIA)

Parameter	Symbol	Min.	Typical	Max.	Unit
9 μ m Core Diameter SMF			20		km
Data Rate		1	4.25		Gbps
Transmitter					
Centre Wavelength	λ_C	1260	1310	1360	nm
Spectral Width (-20dB)	$\Delta\lambda$			1	nm
Average Output Power ^{*(note4)}	Pout	-5		0	dBm
Extinction Ratio ^{*(note5)}	ER	9			dB
Deterministic Jitter@4.25Gbps	D _J	-	-	28.2	ps
Relative Intensity Noise	RIN	-	-	-117	dB/Hz
Optical Rise/Fall Time (20%~80%)	tr/tf			90	ps
TX_Disable Assert Time	t_off			10	us

Eye diagram*(note7)		Compliant with ANSI FC-PI specification			
Receiver					
Center Wavelength	λ_C	1260		1600	nm
Receiver Sensitivity*(note6)	Pmin			-18	dBm
Maximum Input Power (Saturation)	Pmax	-3	-	-	dBm
SD De-Assert	SDD			-19	dBm
SD Assert	SDA	-35			dBm
SD Hysteresis*(note8)		0.5			dB

Note3: LVPECL logic, internally AC coupled.

Note4: Output is coupled into a 9/125 μ m single-mode fiber.

Note5: Filtered, measured with a PRBS 2⁷-1 test pattern @4250Mbps.

Note6: Measured with a 2⁷-1 PRBS and BER less than 1E-12.

Note7: Eye Pattern Mask

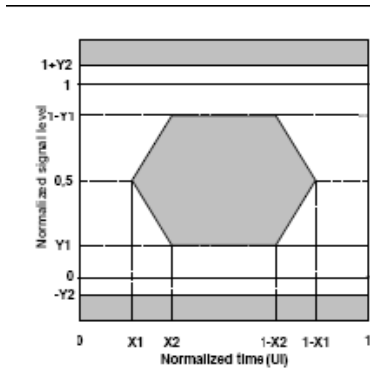

Note8: SD Hysteresis

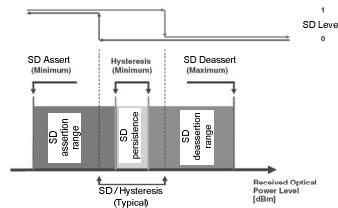

Functional Description of Transceiver

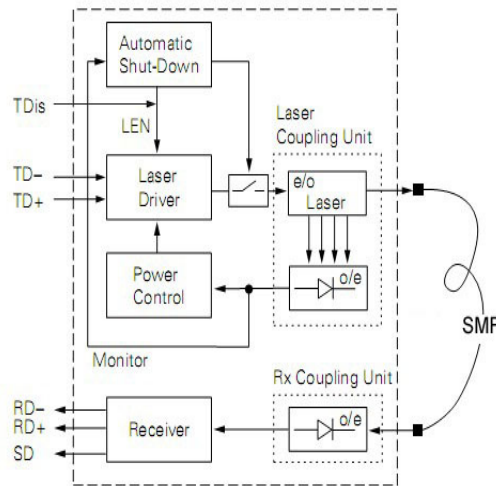

SFF Transceiver Electrical Pad Layout

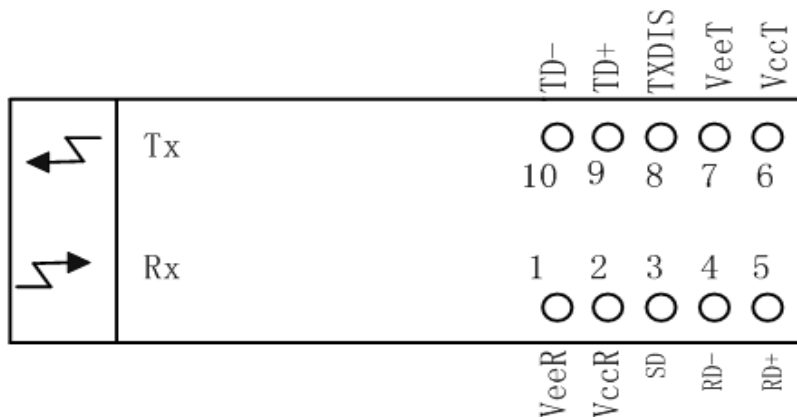

Case isolated from circuit ground.

Pin Function Definitions

Pin No.	Name	Function
	MS	Mounting Studs, Case isolated from circuit ground
1	VeeR	Receiver Signal Ground
2	VccR	3.3V DC power for receiver section
3	SD	Signal Detect Output (LVTTTL) “1” - “Signal valid”, “0” – “Lose of signal”
4	RD-	Received Data Out Bar (LVPECL), without termination inside
5	RD+	Received Data Out (LVPECL), without termination inside
6	VccT	3.3V DC power for transmitter section
7	VeeT	Transmitter Signal Ground
8	TXDIS	Transmitter Disable (LVTTTL), “1” – Disable, “0” – Enable

9	TD+	Transmitter Data In (LVPECL), without termination inside
10	TD-	Transmitter Data In Bar (LVPECL), without termination inside

Recommend Circuit Schematic

AC/AC coupling

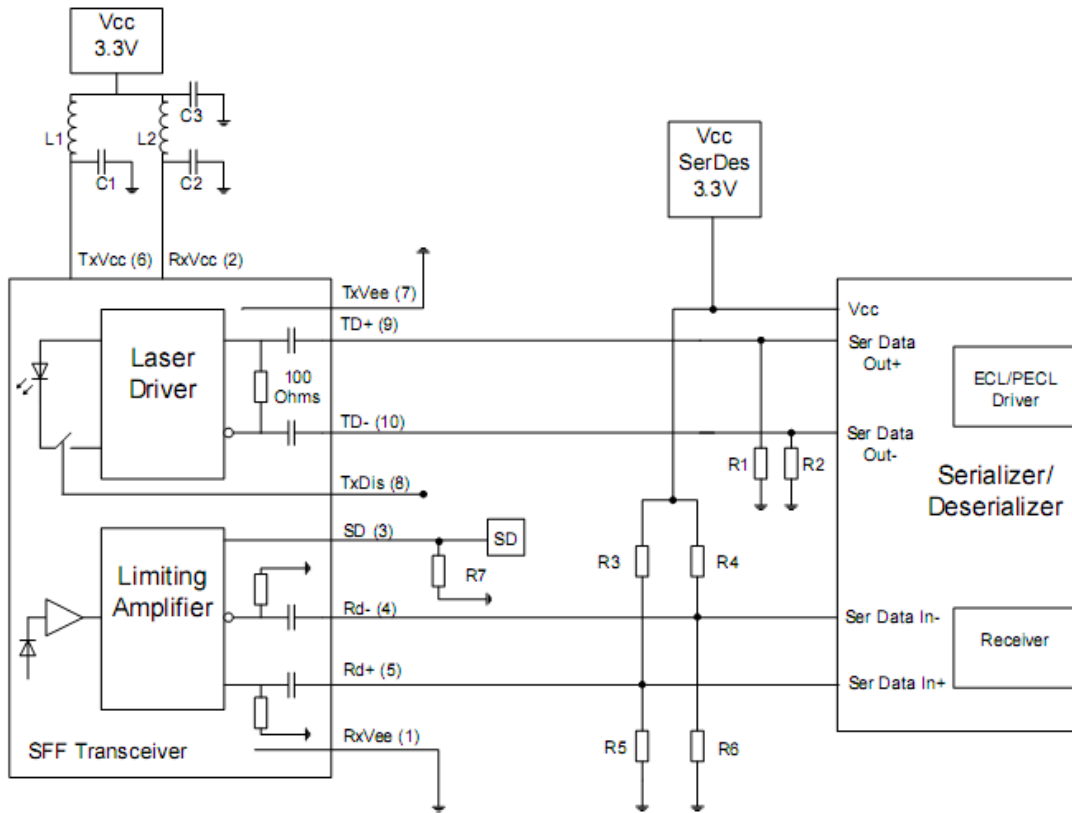

- L1, L2: 1...4.7 μ H
 - C1, C2, C3: 4.7...10 μ F
 - R1, R2: biasing of outputs depending on Serializer
 - R3, R4: 127 Ohms
 - R5, R6: 80 Ohms
 - R7: 510 Ohms for PECL signal detect, open for TTL
- Place R1/2/3/4/5/6 as close to SerDes chip as possible

Mechanical Specifications

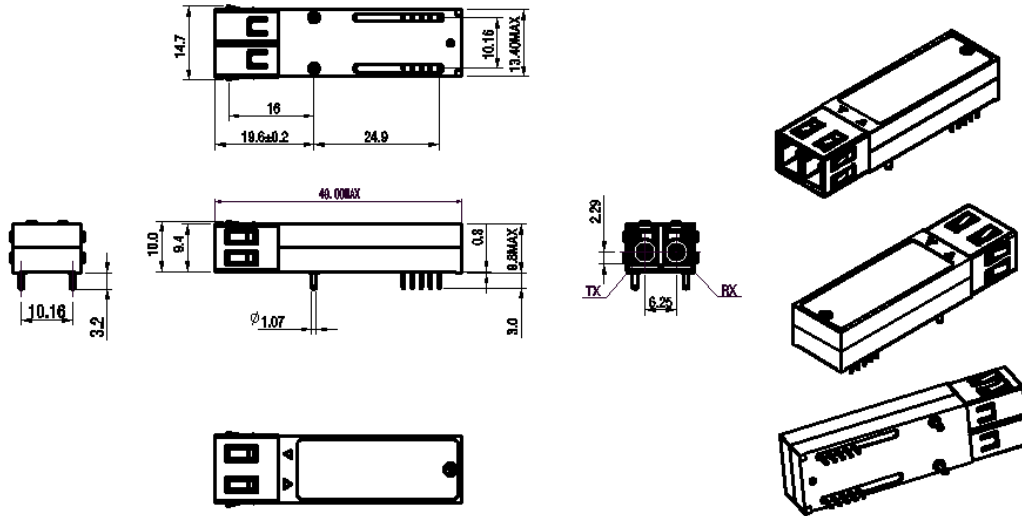

Class 1 Labels

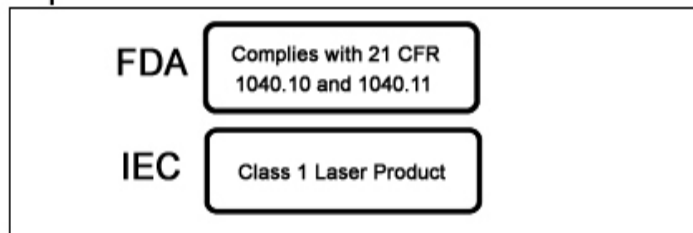

Laser Emission Data

Wavelength	1310nm
Total output power (as defined by FDA: 7 mm aperture at 20 cm distance)	<0.195mW
Total output power (as defined by IEC: 7 mm aperture at 10 cm distance)	<15.6mW
Beam divergence	12.5°

Laser Emission

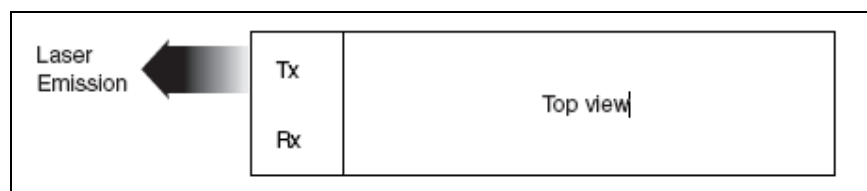

Obtaining Document

You can visit our website:

<http://www.eoptolink.com>

Or contact Eoptolink Technology Inc., Ltd. listed at the end of the documentation to get the latest document.

Revision History

Revision	Initiated	Reviewed	Approved	DCN	Release Date
V3.a	Cathy	Kelly		Released.	Mar 24, 2008

Notice:

Eoptolink reserves the right to make changes to or discontinue any optical link product or service identified in this publication, without notice, in order to improve design and/or performance. Applications that are described herein for any of the optical link products are for illustrative purposes only. Eoptolink makes no representation or warranty that such applications will be suitable for the specified use without further testing or modification.

Contact:

Add: Floor 5, Building 2, No. 21 Gaopeng Avenue, High-Tech District, CHENGDU, SICHUAN
610041 P.R. CHINA

Tel: (+86) 028-85122709 ext 816 & 809

Fax: (+86) 028-85121912

Postal: 610041

E-mail: sales@eoptolink.com

<http://www.eoptolink.com>