

## EOLG-BI1612-X-X series

**Simplex-Mode CWDM 1.25Gbps GBE/FC  
Simplex SC Single-Fiber SFP Transceiver  
RoHS6 Compliant**



### Features

- ◆ Support 1.25Gbps data links
- ◆ A type: 1510nmTx/1590nmRx  
B type: 1590nmTx/1510nmRx
- ◆ 80km with 9/125μm SMF  
120km with 9/125μm SMF
- ◆ 3.3/5V Power supply and TTL Logic Interface
- ◆ Hot-Pluggable SFP Footprint Simplex SC Connector Interface
- ◆ Class 1 FDA and IEC60825-1 laser safety compliant
- ◆ Operating Case Temperature  
Standard: 0°C~+70°C
- ◆ Compliant with GBIC Specification Rev.5.5
- ◆ Compliant with IEEE 802.3z Gigabit Ethernet  
1000BASE-LX
- ◆ Compliant with Fiber Channel FC-PH-2 for  
100-M5-SN-1 and 100-M6-SN-1

### Applications

- ◆ Gigabit Ethernet Switches and Routers
- ◆ Fiber Channel Switch Infrastructure
- ◆ Other optical link

### Ordering information

Part No.	Fiber	Distance* (note2)	Data Rate	Wavelength	Interface	Temp.
EOLG-BI1612-80-MQ <sup>*(note1)</sup>	SMF	80KM	1.25Gbps	1510nm	SC	Standard
EOLG-BI1612-80-QM <sup>*(note1)</sup>	SMF	80KM	1.25Gbps	1590nm	SC	Standard
EOLG-BI1612-B-MQ <sup>*(note1)</sup>	SMF	120KM	1.25Gbps	1510nm	SC	Standard
EOLG-BI1612-B-QM <sup>*(note1)</sup>	SMF	120KM	1.25Gbps	1590nm	SC	Standard

Note1: Standard version

Note2: With 9/125μm SMF

## Regulatory Compliance

Feature	Standard	Performance
Electrostatic Discharge (ESD) to the Electrical Pins	MIL-STD-883G Method 3015.7	Class 1C (>1000 V)
Electrostatic Discharge to the enclosure	EN 55024:1998+A1+A2 IEC-61000-4-2 GR-1089-CORE	Compliant with standards
Electromagnetic Interference (EMI)	FCC Part 15 Class B EN55022:2006 CISPR 22B :2006 VCCI Class B	Compliant with standards Noise frequency range: 30 MHz to 6 GHz. Good system EMI design practice required to achieve Class B margins. System margins are dependent on customer host board and chassis design.
Immunity	EN 55024:1998+A1+A2 IEC 61000-4-3	Compliant with standards. 1kHz sine-wave, 80% AM, from 80 MHz to 1 GHz. No effect on transmitter/receiver performance is detectable between these limits.
Laser Eye Safety	FDA 21CFR 1040.10 and 1040.11 EN (IEC) 60825-1:2007 EN (IEC) 60825-2:2004+A1	CDRH compliant and Class I laser product. TüV Certificate No. 50135086
Component Recognition	UL and CUL EN60950-1:2006	UL file E317337 TüV Certificate No. 50135086 (CB scheme )
RoHS6	2002/95/EC 4.1&4.2 2005/747/EC 5&7&13	Compliant with standards <sup>*note3</sup>

Note3: For update of the equipments and strict control of raw materials, EOPTOLINK has the ability to supply the customized products since Jan 1th, 2007, which meet the requirements of RoHS6 (Restrictions on use of certain Hazardous Substances) of European Union.

In light of item 5 in RoHS exemption list of RoHS Directive 2002/95/EC, Item 5: Lead in glass of cathode ray tubes, electronic components and fluorescent tubes.

In light of item 13 in RoHS exemption list of RoHS Directive 2005/747/EC, Item13: Lead and cadmium in optical and filter glass. The three exemptions are being concerned for Eoptolink's transceivers, because Eoptolink's transceivers use glass, which may contain Pb, for components such as lenses, windows, isolators, and other electronic components.

## Product Description

The EOLG-BI1612-X-X series optical transceivers meet the Gigabit Interface Converter (GBIC) specification Rev.5.5. It satisfies the optical interface specifications defined in IEEE 802.3z Drift 5.0 for Gigabit Ethernet. This module is designed for simplex-mode fiber and operates at a nominal wavelength of 1510nm/1590nm.

The transmitter section uses a multiple quantum well DFB laser and is a class 1 laser compliant according to International Safety Standard IEC-60825. The receiver section uses an integrated InGaAs detector preamplifier (IDP) mounted in an optical header and a limiting post-amplifier IC.

A PECL input / output logic interface is used. TTL RX-LOS output simplifies interface to external circuitry. A 20-pin SCA-2 host connector is used to connect the converter to the host system.

## Absolute Maximum Ratings

Parameter	Symbol	Min.	Max.	Unit
Storage Temperature	$T_s$	-40	+85	°C
Supply Voltage	$V_{CC}$	-0.5	3.6	V
Operating Relative Humidity		-	95	%

\*Exceeding any one of these values may destroy the device immediately.

## Recommended Operating Conditions

Parameter	Symbol		Min.	Typical	Max.	Unit
Operating Case Temperature	$T_A$	EOLG-BI1612-X-X	0		+70	°C
Power Supply Voltage	$V_{CC}$		3.15	3.3	3.45	V
Power Supply Current	$I_{CC}$				300	mA
Data Rate	GBE			1.25		Gbps
	FC			1.063		

## Performance Specifications - Electrical

Parameter	Symbol	Min.	Typ.	Max	Unit	Notes
<b>Transmitter</b>						
LVPECL Inputs(Differential)	$V_{in}$	400		2000	mVpp	AC coupled inputs <sup>+(note5)</sup>
Input Impedance (Differential)	$Z_{in}$	85	100	115	ohms	$R_{in} > 100$ kohms @ DC
Tx_Dis	Disable	2		$V_{CC}$	V	
	Enable	0		0.8		
Tx_FAULT	Fault	2		$V_{CC}+0.3$	V	
	Normal	0		0.5		

Receiver						
LVPECL Outputs (Differential)	Vout	370		2000	mVpp	AC coupled outputs <sup>*(note5)</sup>
Output Impedance (Differential)	Zout	85	100	115	ohms	
Rx_LOS	LOS	2		Vcc+0.3	V	
	Normal	0		0.8	V	
MOD_DEF ( 0:2 )	VoH	2.5			V	With Serial ID
	VoL	0		0.5	V	

## Optical and Electrical Characteristics

### (EOLG-BI1612-80-MQ, 1510nm DFB and PIN)

Parameter	Symbol	Min.	Typical	Max.	Unit
9µm Core Diameter SMF	L		80		km
Data Rate			1.063/1.25		Gbps
Transmitter					
Centre Wavelength	$\lambda_c$	1480		1520	nm
Spectral Width (-20 dB)	$\Delta\lambda$			1	nm
Average Output Power <sup>*(note3)</sup>	Pout	-2		3	dBm
Extinction Ratio <sup>*(note4)</sup>	ER	9			dB
Rise/Fall Time(20%~80%)	tr/tf			0.26	ns
Total Jitter	TJ			227	ps
Output Optical Eye <sup>*(note4)</sup>	Compatible with IEEE 802.3ah-2004 <sup>*(note7)</sup>				
TX_Disable Assert Time	t_off			10	us
Receiver					
Centre Wavelength	$\lambda$	1580		1620	nm
Receiver Sensitivity <sup>*(note6)</sup>	GBE	Pmin		-26	dBm
	FC			-26	
Receiver Overload	Pmax	-3			dBm
LOS De-Assert	LOSD			-26	dBm
LOS Assert	LOSA	-40			dBm
LOS Hysteresis <sup>*(note8)</sup>		1.0			dB

### (EOLG-BI1612-80-QM, 1590nm DFB and PIN)

Parameter	Symbol	Min.	Typical	Max.	Unit
9µm Core Diameter SMF	L		80		km
Data Rate			1.063/1.25		Gbps
Transmitter					
Centre Wavelength	$\lambda_c$	1580		1620	nm
Spectral Width (-20 dB)	$\Delta\lambda$			1	nm
Average Output Power <sup>*(note3)</sup>	Pout	-2		3	dBm
Extinction Ratio <sup>*(note4)</sup>	ER	9			dB
Rise/Fall Time(20%~80%)	tr/tf			0.26	ns

Total Jitter	TJ			227	ps
Output Optical Eye <sup>*(note4)</sup>	Compatible with IEEE 802.3ah-2004 <sup>*(note7)</sup>				
TX_Disable Assert Time	t_off			10	us
P <sub>out</sub> @TX Disable Asserted	P <sub>out</sub>			-45	dBm
<b>Receiver</b>					
Centre Wavelength	$\lambda$	1480		1520	nm
Receiver Sensitivity <sup>*(note6)</sup>	GBE	P <sub>min</sub>		-26	dBm
	FC			-26	dBm
Receiver Overload	P <sub>max</sub>	-3			dBm
LOS De-Assert	LOSD			-27	dBm
LOS Assert	LOSA	-40			dBm
LOS Hysteresis <sup>*(note8)</sup>		1.0			dB

### (EOLG-BI1612-B-MQ, 1510nm DFB and APD)

Parameter	Symbol	Min.	Typical	Max.	Unit
9 $\mu$ m Core Diameter SMF	L		120		km
Data Rate			1.063/1.25		Gbps
<b>Transmitter</b>					
Centre Wavelength	$\lambda_c$	1480		1520	nm
Spectral Width (-20 dB)	$\Delta\lambda$			1	nm
Average Output Power <sup>*(note3)</sup>	P <sub>out</sub>	-2		3	dBm
Extinction Ratio <sup>*(note4)</sup>	ER	9			dB
Rise/Fall Time(20%~80%)	tr/tf			0.26	ns
Total Jitter	TJ			227	ps
Output Optical Eye <sup>*(note4)</sup>	Compatible with IEEE 802.3ah-2004 <sup>*(note7)</sup>				
TX_Disable Assert Time	t_off			10	us
<b>Receiver</b>					
Centre Wavelength	$\lambda$	1580		1620	nm
Receiver Sensitivity <sup>*(note6)</sup>	GBE	P <sub>min</sub>		-33	dBm
	FC			-33	dBm
Receiver Overload	P <sub>max</sub>	-10			dBm
LOS De-Assert	LOSD			-26	dBm
LOS Assert	LOSA	-40			dBm
LOS Hysteresis <sup>*(note8)</sup>		1.0			dB

### (EOLG-BI1612-B-QM, 1590nm DFB and APD)

Parameter	Symbol	Min.	Typical	Max.	Unit
9 $\mu$ m Core Diameter SMF	L		120		km
Data Rate			1.063/1.25		Gbps
<b>Transmitter</b>					
Centre Wavelength	$\lambda_c$	1580		1620	nm
Spectral Width (-20 dB)	$\Delta\lambda$			1	nm
Average Output Power <sup>*(note3)</sup>	P <sub>out</sub>	-2		3	dBm
Extinction Ratio <sup>*(note4)</sup>	ER	9			dB

Rise/Fall Time(20%~80%)	tr/tf			0.26	ns
Total Jitter	TJ			227	ps
Output Optical Eye <sup>*(note4)</sup>	Compatible with IEEE 802.3ah-2004 <sup>*(note7)</sup>				
TX_Disable Assert Time	t_off			10	us
P <sub>out</sub> @TX Disable Asserted	P <sub>out</sub>			-45	dBm
<b>Receiver</b>					
Centre Wavelength	$\lambda$	1480		1520	nm
Receiver Sensitivity <sup>*(note6)</sup>	GBE	P <sub>min</sub>		-33	dBm
	FC			-33	dBm
Receiver Overload	P <sub>max</sub>	-10			dBm
LOS De-Assert	LOSD			-26	dBm
LOS Assert	LOSA	-40			dBm
LOS Hysteresis <sup>*(note8)</sup>		1.0			dB

Note3: Output is coupled into a 9/125 $\mu$ m SMF

Note4: Filtered, measured with a PRBS 2<sup>7</sup>-1 test pattern @1.25Gbps.

Note5: LVPECL logic, internally AC coupled.

Note6: Minimum average optical power measured at BER less than 1E-12, with a 2<sup>7</sup>-1 PRBS and ER=9 dB.

Note7: Eye pattern mask

Note8: LOS Hysteresis

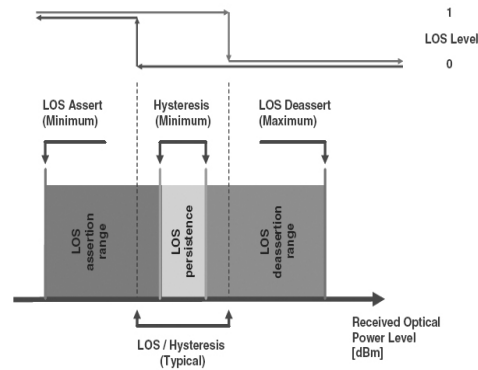
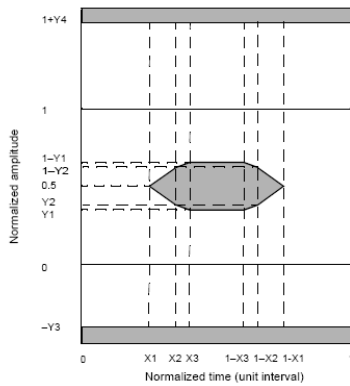

## Functional Description of Transceiver

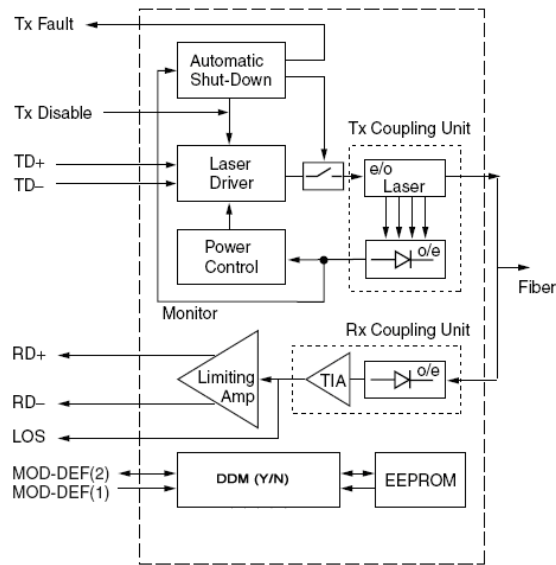

## GBIC Transceiver Electrical Pad Layout

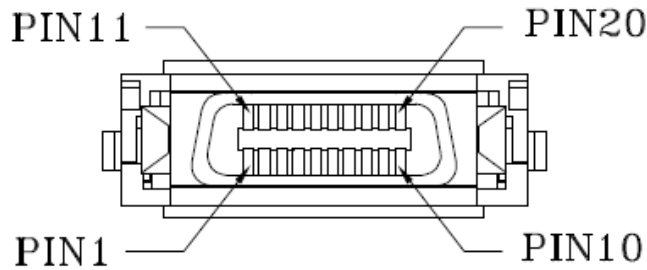

Pin Name	Pin#	Sequence
RX_LOS	1	2
RGND	2	2
RGND	3	2
MOD_DEF(0)	4	2
MOD_DEF(1)	5	2
MOD_DEF(2)	6	2
TX_DISABLE	7	2
TGND	8	2
TGND	9	2
TX_FAULT	10	2
RGND	11	1
-RX_DAT	12	1
+RX_DAT	13	1
RGND	14	1

VDDR	15	2
VDDT	16	2
TGND	17	1
+TX_DAT	18	1
-TX_DAT	19	1
TGND	20	1

## Pin Function Definitions

Pin Name	Pin #	Name/Function	Signal Specification
<b>Receiver Signals</b>			
RGND	2,3,11, 14	Receiver Ground(may be connected with TGND in GBIC)	Ground, to GBIC
VDDR	15	Receiver +5 volt (may be connected with VDDT in GBIC)	Power, to GBIC
-RX_DAT	12	Receive Data, Differential PECL	High speed serial, from GBIC
+RX_DAT	13	Receive Data, Differential PECL	High speed serial, from GBIC
RX_LOS	1	Receiver Loss of Signal, logic high, open collector compatible,4.7 K to 10 K Ohm pullup to VDDT on host	Low speed, from GBIC
<b>Transmitter Signals</b>			
TGND	8,9,17, 20	Transmitter Ground (may be connected with RGND internally)	Ground, to GBIC
VDDT	16	Transmitter +5 volt (may be connected with VDDR in GBIC)	Power, to GBIC
+TX_DAT	18	Transmit Data, Differential PECL	High speed serial, to GBIC
-TX_DAT	19	Transmit Data, Differential PECL	High speed serial, to GBIC
TX_DISABLE	7	Transmitter Disable, logic high, open collector compatible,4.7K to 10 K Ohm pullup to VDDT on GBIC	Low speed, to GBIC
TX_FAULT	10	Transmitter Fault, logic high, open collector compatible,4.7 Kto 10 K Ohm pullup to VDDT on host	Low speed, from GBIC
<b>Control Signals</b>			
MOD_DEF(0)	4	GBIC module definition and presence, bit 0,4.7 K to 10 K Ohm pullup to VDDT on host	Low speed, from GBIC

MOD_DEF(1)	5	GBIC module definition and presence, bit 1,4.7 K to 10 K Ohm pullup to VDDT on host	Low speed, from GBIC
MOD_DEF(2)	6	GBIC module definition and presence, bit 2,4.7 K to 10 K Ohm pullup to VDDT on host	Low speed, from GBIC

## EEPROM

The serial interface uses the 2-wire serial CMOS EEPROM protocol defined for the ATMEL AT24C02/04 family of components. When the serial protocol is activated, the host generates the serial clock signal (SCL). The positive edge clocks data into those segments of the EEPROM that are not writing protected within the SFP transceiver. The negative edge clocks data from the SFP transceiver. The serial data signal (SDA) is bi-directional for serial data transfer. The host uses SDA in conjunction with SCL to mark the start and end of serial protocol activation. The memories are organized as a series of 8-bit data words that can be addressed individually or sequentially.

## EEPROM Serial ID Memory Contents

Accessing Serial ID Memory uses the 2 wire address 1010000X (A0). Memory Contents of Serial ID are shown in Table 1.

**Table 1 Serial ID Memory Contents**

Addr.	Size (Bytes)	Name of Field	Hex	Description
<b>BASE ID FIELDS</b>				
0	1	Identifier	01	GBIC
1	1	Ext. Identifier	04	SFP function is defined by serial ID only
2	1	Connector	01	SC Connector
3-10	8	Transceiver	XX XX XX XX XX XX XX XX <sup>(note9)</sup>	Transmitter Code
11	1	Encoding	01	8B10B
12	1	BR, Nominal	0D	1.25Gbps
13	1	Reserved	00	
14	1	Length (9µm)km	XX	Transceiver transmit distance
15	1	Length(9µm)100m	XX	
16	1	Length (50µm)	00	
17	1	Length(62.5µm)	00	
18	1	Length (Copper)	00	Not compliant
19	1	Reserved	00	

20-35	16	Vendor name	XX XX XX XX XX XX XX XX <sup>(note9)</sup> 20 20 20 20 20 20 20 20	Vendor name (ASCII)
36	1	Reserved	00	
37-39	3	Vendor OUI	XX XX XX <sup>(note9)</sup>	
40-55	16	Vendor PN	XX XX XX XX XX XX XX XX XX XX XX XX XX XX XX XX <sup>(note9)</sup>	Transceiver part number
56-59	4	Vendor rev	XX XX XX XX <sup>(note9)</sup>	
60-61	2	Wavelength	05 E6 / 06 36	1510nm/1590nm
62	1	Reserved	00	
63	1	CC_BASE	Check Sum (Variable)	Check code for Base ID Fields
<b>EXTENDED ID FIELDS</b>				
64-65	2	Options	00 1A	TX_DISABLE, TX_FAULT and Loss of Signal implemented.
66	1	BR,max	00	
67	1	BR,min	00	
68-83	16	Vendor SN	XX XX XX XX XX XX XX XX 20 20 20 20 20 20 20 20 <sup>(note9)</sup>	Serial Number of transceiver (ASCII). For example "B000822".
84-91	8	Date code	XX XX XX XX XX XX XX XX <sup>(note9)</sup>	Manufactory date code. For example "080405".
92	1	Diagnostic Monitoring Type	00	Digital diagnostic monitoring implemented
93	1	Enhanced Options	00	Optional flags
94	1	SFF_8472 Compliance	00	01 for diagnostics (Rev9.3 SFF-8472).
95	1	CC_EXT	Check Sum (Variable)	Check sum for Extended ID Field.
<b>VENDOR SPECIFIC ID FIELDS</b>				
96-127	32	Vendor Specific	Read only	Depends on customer information
128-255	128	Reserved	Read only	

Note9: The "XX" byte should be filled in according to practical case. For more information, please refer to the related document of SFP Multi-Source Agreement (MSA).

## Recommend Circuit Schematic

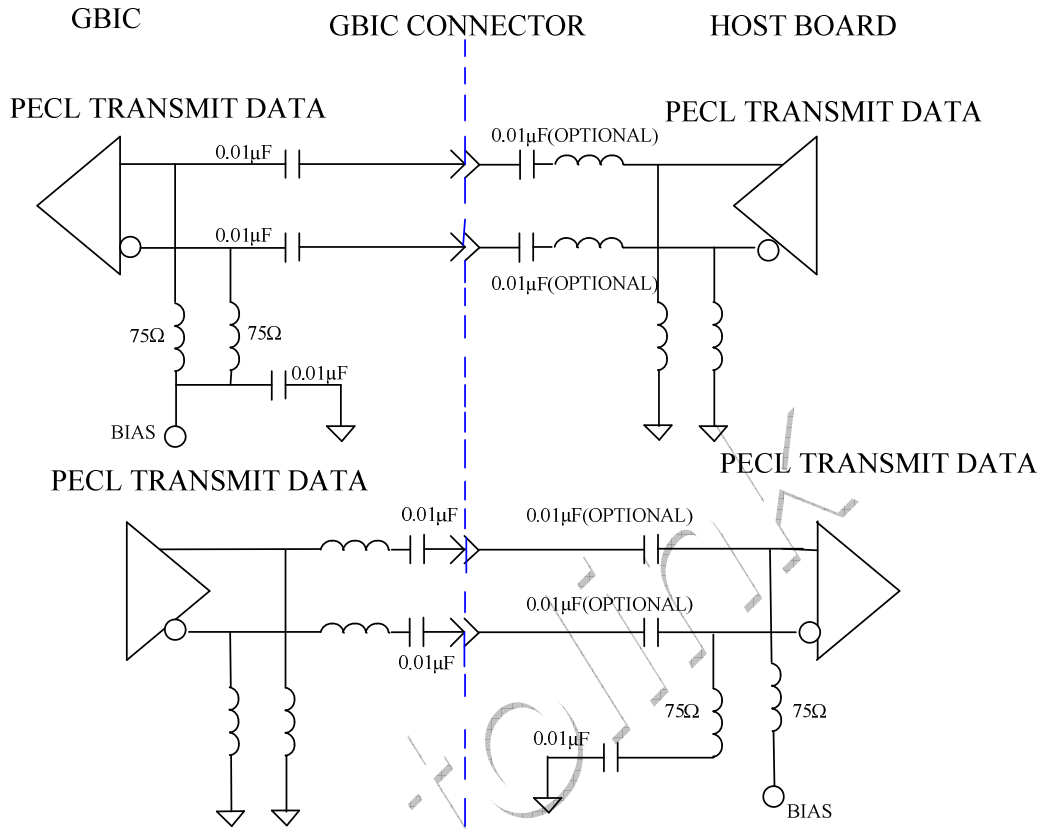

**Mechanical Specifications**

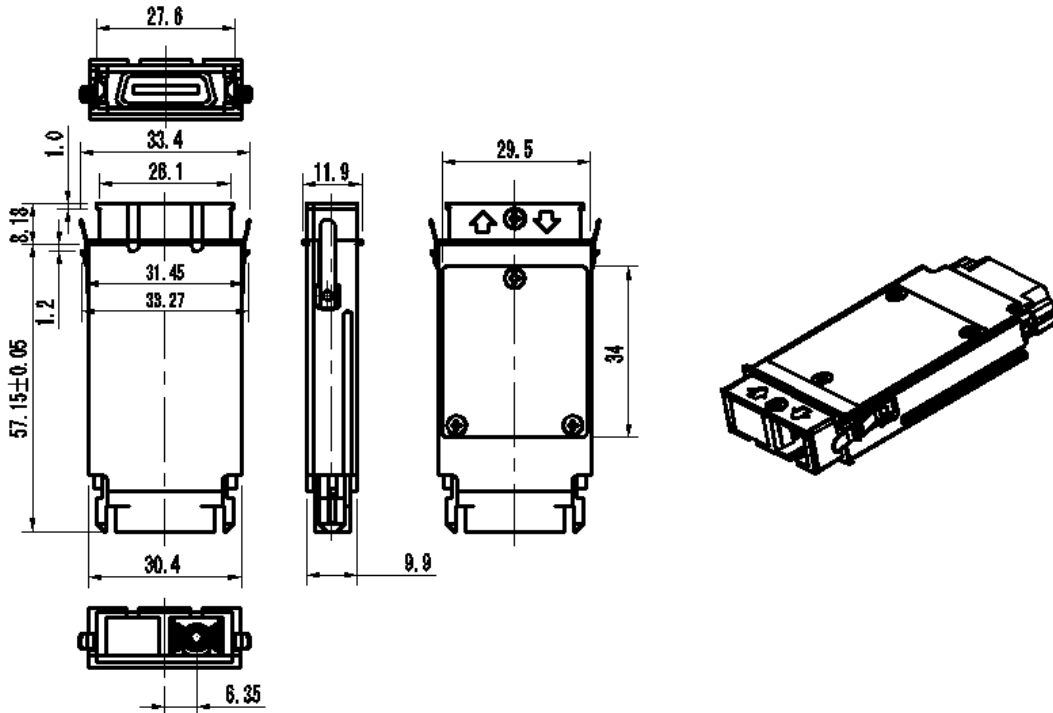

## Class 1 Labels

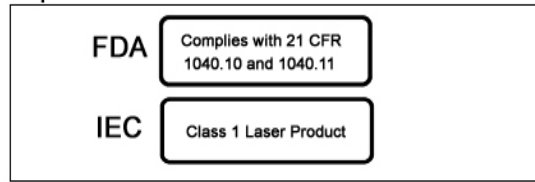

## Laser Emission Data

Wavelength	> 1460nm
Total output power (as defined by FDA: 7 mm aperture at 20 cm distance)	<0.79mW
Total output power (as defined by IEC: 7 mm aperture at 10 cm distance)	<10mW
Beam divergence	12.5°

## Laser Emission

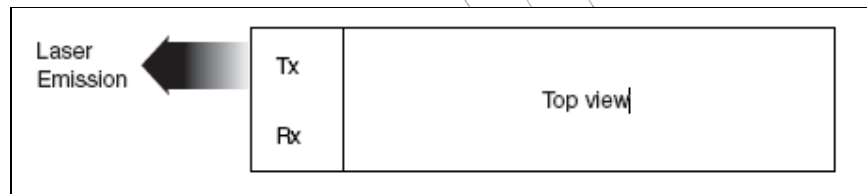

## Obtaining Document

You can visit our website:

<http://www.eoptolink.com>

Or contact Eoptolink Technology Inc., Ltd. listed at the end of the documentation to get the latest documents.

## Revision History

Revision	Initiated	Reviewed	Approved	Revision History	Date
V3.a	Cathy	Kelly		Released.	Mar 27, 2008

## Notice:

Eoptolink reserves the right to make changes to or discontinue any optical link product or service identified in this publication, without notice, in order to improve design and/or performance. Applications that are described herein for any of the optical link products are for illustrative purposes only. Eoptolink makes no representation or warranty that such applications will be suitable for the specified use without further testing or modification.

### Contact:

Add: Floor 5 Building 2 No. 21 Gaopeng Avenue High-Tech District CHENGDU, SICHUAN 610041  
P.R. CHINA

Tel: (+86) 028-85122709 ext 816 & 809

Fax: (+86) 028-85121912

Postal: 610041

E-mail: [sales@eoptolink.com](mailto:sales@eoptolink.com)

<http://www.eoptolink.com>