

## EOLS-BI1306-80 Series

## EOLS-BI1506-80 Series

Single-Mode 622Mbps SDH /SONET  
Simplex SC/LC Single-Fiber SFP Transceiver  
RoHS6 Compliant

### Features

- ◆ Support 155Mbps data links
- ◆ A type: 1310nm DFB Tx/1550nmRx  
B type: 1550nm DFB TX/1310nmRx
- ◆ 80km with 9/125 μm SMF
- ◆ Single 3.3V Power supply and TTL Logic Interface
- ◆ Hot-Pluggable SFP Footprint Simplex SC/LC Connector Interface
- ◆ Class 1 FDA and IEC60825-1 laser safety compliant
- ◆ Operating Case Temperature  
Standard: 0°C~+70°C  
Industrial:-40°C~+85°C
- ◆ Compliant with SFP MSA
- ◆ Compliant with SFF-8472



### Applications

- ◆ SONET OC-12 / SDH STM-4
- ◆ WDM Fast Ethernet Links

### Ordering information

| Part No.                            | Data Rate | Wavelength | Interface | Temp.      | DDMI |
|-------------------------------------|-----------|------------|-----------|------------|------|
| EOLS-BI1306-80 <sup>*(note1)</sup>  | 622Mbps   | 1310nm     | SC        | Standard   | NO   |
| EOLS-BI1506-80 <sup>*(note1)</sup>  | 622Mbps   | 1550nm     | SC        | Standard   | NO   |
| EOLS-BI1306-80I                     | 622Mbps   | 1310nm     | SC        | Industrial | NO   |
| EOLS-BI1506-80I                     | 622Mbps   | 1550nm     | SC        | Standard   | NO   |
| EOLS-BI1306-80D                     | 622Mbps   | 1310nm     | SC        | Standard   | YES  |
| EOLS-BI1506-80D                     | 622Mbps   | 1550nm     | SC        | Standard   | YES  |
| EOLS-BI1306-80DI                    | 622Mbps   | 1310nm     | SC        | Industrial | YES  |
| EOLS-BI1506-80DI                    | 622Mbps   | 1550nm     | SC        | Standard   | YES  |
| EOLS-BI1306-80L <sup>*(note1)</sup> | 622Mbps   | 1310nm     | LC        | Standard   | NO   |
| EOLS-BI1506-80L <sup>*(note1)</sup> | 622Mbps   | 1550nm     | LC        | Standard   | NO   |

|                   |         |        |    |            |     |
|-------------------|---------|--------|----|------------|-----|
| EOLS-BI1306-80IL  | 622Mbps | 1310nm | LC | Industrial | NO  |
| EOLS-BI1506-80IL  | 622Mbps | 1550nm | LC | Standard   | NO  |
| EOLS-BI1306-80DL  | 622Mbps | 1310nm | LC | Standard   | YES |
| EOLS-BI1506-80DL  | 622Mbps | 1550nm | LC | Standard   | YES |
| EOLS-BI1306-80DIL | 622Mbps | 1310nm | LC | Industrial | YES |
| EOLS-BI1506-80DIL | 622Mbps | 1550nm | LC | Standard   | YES |

Note1: Standard version

## Regulatory Compliance

| Feature  | Standard   | Performance   |
|--|--|---|
| Electrostatic Discharge (ESD) to the Electrical Pins | MIL-STD-883G<br>Method 3015.7  | Class 1C (>1000 V)  |
| Electrostatic Discharge to the enclosure             | EN 55024:1998+A1+A2<br>IEC-61000-4-2<br>GR-1089-CORE                               | Compatible with standards   |
| Electromagnetic Interference (EMI)                   | FCC Part 15 Class B<br>EN55022:2006<br>CISPR 22B :2006<br>VCCI Class B             | Compatible with standards<br>Noise frequency range: 30 MHz to 6 GHz. Good system EMI design practice required to achieve Class B margins. System margins are dependent on customer host board and chassis design. |
| Immunity   | EN 55024:1998+A1+A2<br>IEC 61000-4-3   | Compatible with standards.<br>1kHz sine-wave, 80% AM, from 80 MHz to 1 GHz. No effect on transmitter/receiver performance is detectable between these limits.   |
| Laser Eye Safety                                     | FDA 21CFR 1040.10 and 1040.11<br>EN (IEC) 60825-1:2007<br>EN (IEC) 60825-2:2004+A1 | CDRH compliant and Class I laser product.<br>TüV Certificate No. 50135086   |
| Component Recognition                                | UL and CUL<br>EN60950-1:2006   | UL file E317337<br>TüV Certificate No. 50135086<br>(CB scheme )   |
| RoHS6  | 2002/95/EC 4.1&4.2<br>2005/747/EC 5&7&13   | Compliant with standards <sup>*note2</sup>  |

Note2: For update of the equipments and strict control of raw materials, EOPTOLINK has the ability to supply the customized products since Jan 1th, 2007, which meet the requirements of RoHS6 (Restrictions on use of certain Hazardous Substances) of European Union.

In light of item 5 in RoHS exemption list of RoHS Directive 2002/95/EC, Item 5: Lead in glass of cathode ray tubes,

electronic components and fluorescent tubes.

In light of item 13 in RoHS exemption list of RoHS Directive 2005/747/EC, Item13: Lead and cadmium in optical and filter glass. The three exemptions are being concerned for Eoptolink's transceivers, because Eoptolink's transceivers use glass, which may contain Pb, for components such as lenses, windows, isolators, and other electronic components.

## Product Description

The EOLS-BI1X06-X series is small form factor pluggable module for OC-3/STM-1 OC-12/STM-4 SONET/SDH and Fibre Channel single fiber communications by using 1310nm/1550nm transmitter and 1550nm/1310nm receiver. It is with the SFP 20-pin connector to allow hot plug capability.

The transmitter section uses a multiple quantum well A type/ B type laser and is a class 1 laser compliant according to International Safety Standard IEC 60825. The receiver section uses an integrated B type/ A type detector preamplifier (IDP) mounted in an optical header and a limiting post-amplifier IC.

The EOLS-BI1X06-XD series are designed to be compliant with SFF-8472 SFP Multi-source Agreement (MSA).

## Absolute Maximum Ratings

| Parameter                   | Symbol   | Min. | Max. | Unit |
|-----------------------------|----------|------|------|------|
| Storage Temperature         | $T_s$    | -40  | +85  | °C   |
| Supply Voltage              | $V_{CC}$ | -0.5 | 3.6  | V    |
| Operating Relative Humidity |          | -    | 95   | %    |

\*Exceeding any one of these values may destroy the device immediately.

## Recommended Operating Conditions

| Parameter                  | Symbol      | Min.         | Typical | Max. | Unit |    |
|----------------------------|-------------|--------------|---------|------|------|----|
| Operating Case Temperature | $T_A$       | EOLS-1X06-X  | 0       |      | +70  | °C |
|                            |             | EOLS-1X06-XI | -40     |      | +85  |    |
| Power Supply Voltage       | $V_{CC}$    | 3.15         | 3.3     | 3.45 | V    |    |
| Power Supply Current       | $I_{CC}$    |              |         | 300  | mA   |    |
| Date Rate                  | OC-12/STM-4 |              | 622     |      | Mbps |    |

## Performance Specifications - Electrical

| Parameter                      | Symbol   | Min. | Typ. | Max      | Unit | Notes                                 |
|--------------------------------|----------|------|------|----------|------|---------------------------------------|
| <b>Transmitter</b>             |          |      |      |          |      |                                       |
| LVPECL Inputs(Differential)    | $V_{in}$ | 400  |      | 2000     | mVpp | AC coupled inputs <sup>*(note5)</sup> |
| Input Impedance (Differential) | $Z_{in}$ | 85   | 100  | 115      | ohms | $R_{in} > 100$ kohms @ DC             |
| Tx_Dis                         | Disable  | 2    |      | $V_{CC}$ | V    |                                       |
|                                | Enable   | 0    |      | 0.8      |      |                                       |

|                                 |        |                  |     |     |                      |                  |  |
|---------------------------------|--------|------------------|-----|-----|----------------------|------------------|--|
| Tx_FAULT                        | Fault  |                  | 2   |     | V <sub>CC</sub> +0.3 | V                |  |
|                                 | Normal |                  | 0   |     | 0.5                  |                  |  |
| <b>Receiver</b>                 |        |                  |     |     |                      |                  |  |
| LVPECL Outputs (Differential)   |        | V <sub>out</sub> | 370 |     | 2000                 | mV <sub>pp</sub> | AC coupled outputs <sup>*(note5)</sup> |
| Output Impedance (Differential) |        | Z <sub>out</sub> | 85  | 100 | 115                  | ohms             |  |
| Rx_LOS                          | LOS    |                  | 2   |     | V <sub>CC</sub> +0.3 | V                |  |
|                                 | Normal |                  | 0   |     | 0.8                  | V                |  |
| MOD_DEF ( 0:2 )                 |        | VoH              | 2.5 |     |                      | V                | With Serial ID                         |
|                                 |        | VoL              | 0   |     | 0.5                  | V                |  |

## Optical and Electrical Characteristics

### (EOLS-BI1306-80, 1310nm DFB and PIN, 80km)

| Parameter                                | Symbol                                    | Min. | Typical | Max. | Unit |
|--|---|------|---------|------|------|
| 9µm Core Diameter SMF                    | L   |      | 80      |      | km   |
| Data Rate                                |   |      | 622     |      | Mbps |
| <b>Transmitter</b>                       |   |      |         |      |      |
| Centre Wavelength                        | $\lambda_c$                               | 1260 | 1310    | 1360 | nm   |
| Spectral Width (-20dB)                   | $\Delta\lambda$                           |      |         | 1    | nm   |
| Average Output Power <sup>*(note3)</sup> | P <sub>out</sub>                          | 0    |         | 5    | dBm  |
| Extinction Ratio <sup>*(note4)</sup>     | ER  | 8.2  |         |      | dB   |
| Rise/Fall Time(20%~80%)                  | tr/tf                                     |      |         | 1.2  | ns   |
| Output Optical Eye <sup>*(note4)</sup>   | IUT-T G.957 Compliant <sup>*(note7)</sup> |      |         |      |      |
| TX_Disable Assert Time                   | t <sub>off</sub>                          |      |         | 10   | µs   |
| P <sub>out</sub> @TX Disable Asserted    | P <sub>out</sub>                          |      |         | -45  | dBm  |
| <b>Receiver</b>                          |   |      |         |      |      |
| Centre Wavelength                        | $\lambda$                                 | 1500 | 1550    | 1580 | nm   |
| Receiver Sensitivity <sup>*(note6)</sup> | P <sub>min</sub>                          |      |         | -28  | dBm  |
| Receiver Overload                        | P <sub>max</sub>                          | -3   |         |      | dBm  |
| LOS De-Assert                            | LOSD                                      |      |         | -29  | dBm  |
| LOS Assert                               | LOSA                                      | -42  |         |      | dBm  |
| LOS Hysteresis <sup>*(note8)</sup>       |   | 0.5  |         |      | dB   |

### (EOLS-BI1506-80, 1550nm DFB and PIN, 80km)

| Parameter                                | Symbol           | Min. | Typical | Max. | Unit |
|--|------------------|------|---------|------|------|
| 9µm Core Diameter SMF                    | L                |      | 80      |      | km   |
| Data Rate                                |                  |      | 622     |      | Mbps |
| <b>Transmitter</b>                       |                  |      |         |      |      |
| Centre Wavelength                        | $\lambda_c$      | 1480 | 1550    | 1580 | nm   |
| Spectral Width (-20dB)                   | $\Delta\lambda$  |      |         | 1    | nm   |
| Average Output Power <sup>*(note3)</sup> | P <sub>out</sub> | 0    |         | 5    | dBm  |
| Extinction Ratio <sup>*(note4)</sup>     | ER               | 8.2  |         |      | dB   |

|  |   |      |  |      |     |
|--|---|------|--|------|-----|
| Side Mode Suppression Ratio              | SMSR                                      | 30   |  |      | dB  |
| Rise/Fall Time(20%~80%)                  | tr/tf                                     |      |  | 1.2  | ns  |
| Output Optical Eye <sup>*(note4)</sup>   | IUT-T G.957 Compliant <sup>*(note7)</sup> |      |  |      |     |
| TX_Disable Assert Time                   | t_off                                     |      |  | 10   | □us |
| <b>Receiver</b>                          |   |      |  |      |     |
| Centre Wavelength                        | $\lambda$                                 | 1260 |  | 1600 | nm  |
| Receiver Sensitivity <sup>*(note6)</sup> | Pmin                                      |      |  | -28  | dBm |
| Receiver Overload                        | Pmax                                      | -3   |  |      | dBm |
| Return Loss                              |   | 12   |  |      | dB  |
| Optical Path Penalty                     |   |      |  | 1    | dB  |
| LOS De-Assert                            | LOSD                                      |      |  | -29  | dBm |
| LOS Assert                               | LOSA                                      | -45  |  |      | dBm |
| LOS Hysteresis <sup>*(note8)</sup>       |   | 0.5  |  |      | dB  |

Note3: Output power is power coupled into a 9/125 $\mu$ m single-mode fiber.

Note4: Filtered, measured with a PRBS 2<sup>23</sup>-1 test pattern @622Mbps

Note5: LVPECL logic, internally AC coupled.

Note6: Minimum average optical power measured at BER less than 1E-10, with a 2<sup>23</sup>-1 PRBS and ER=9 dB.

Note7: Eye pattern mask

Note8: LOS Hysteresis

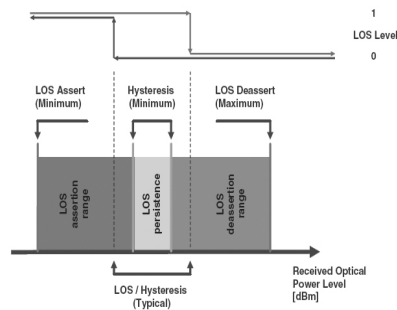
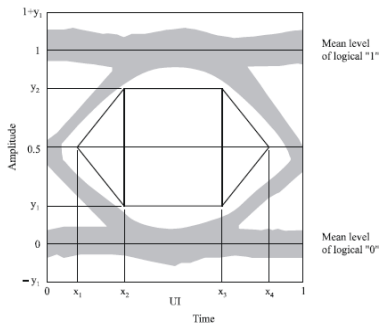

## Functional Description of Transceiver

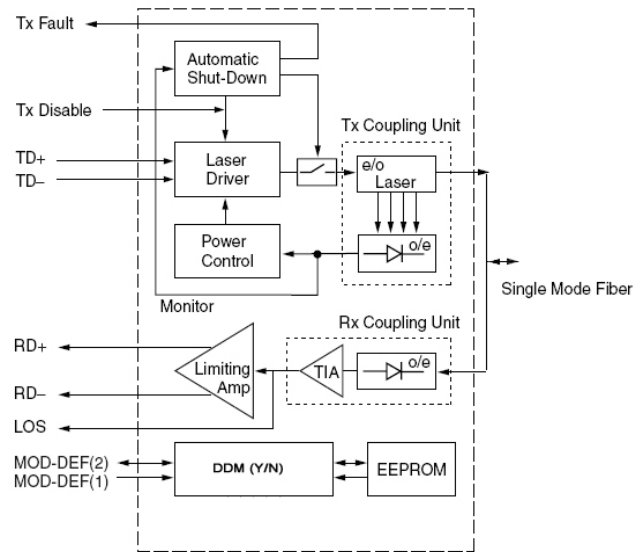

### SFP Transceiver Electrical Pad Layout

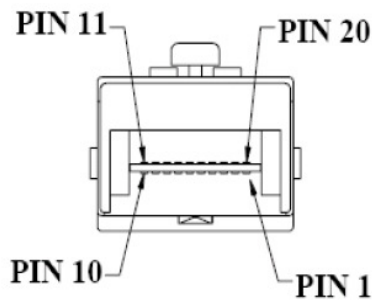
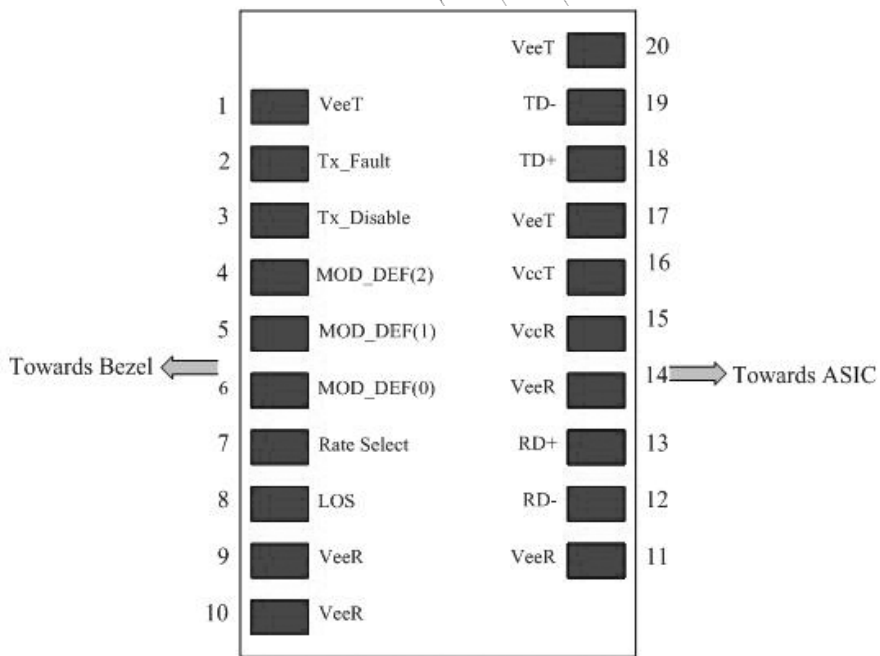

## Pin Function Definitions

| Pin Num. | Name        | FUNCTION                     | Plug Seq. | Notes                               |
|----------|-------------|------------------------------|-----------|-------------------------------------|
| 1        | VeeT        | Transmitter Ground           | 1         | 5)                                  |
| 2        | TX Fault    | Transmitter Fault Indication | 3         | 1)                                  |
| 3        | TX Disable  | Transmitter Disable          | 3         | 2), Module disables on high or open |
| 4        | MOD-DEF2    | Module Definition 2          | 3         | 3), Data line for Serial ID.        |
| 5        | MOD-DEF1    | Module Definition 1          | 3         | 3), Clock line for Serial ID.       |
| 6        | MOD-DEF0    | Module Definition 0          | 3         | 3), Grounded within the module.     |
| 7        | Rate Select | Not Connect                  | 3         | Function not available              |
| 8        | LOS         | Loss of Signal               | 3         | 4)                                  |
| 9        | VeeR        | Receiver Ground              | 1         | 5)                                  |
| 10       | VeeR        | Receiver Ground              | 1         | 5)                                  |
| 11       | VeeR        | Receiver Ground              | 1         | 5)                                  |
| 12       | RD-         | Inv. Received Data Out       | 3         | 6)                                  |
| 13       | RD+         | Received Data Out            | 3         | 7)                                  |
| 14       | VeeR        | Receiver Ground              | 1         | 5)                                  |
| 15       | VccR        | Receiver Power               | 2         | 3.3 ± 5%, 7)                        |
| 16       | VccT        | Transmitter Power            | 2         | 3.3 ± 5%, 7)                        |
| 17       | VeeT        | Transmitter Ground           | 1         | 5)                                  |
| 18       | TD+         | Transmit Data In             | 3         | 8)                                  |
| 19       | TD-         | Inv. Transmit Data In        | 3         | 8)                                  |
| 20       | VeeT        | Transmitter Ground           | 1         | 5)                                  |

### Notes:

1) TX Fault is an open collector/drain output, which should be pulled up with a 4.7K – 10KΩ resistor on the host board. Pull up voltage between 2.0V and VccT, R+0.3V. When high, output indicates a laser fault of some kind. Low indicates normal operation. In the low state, the output will be pulled to < 0.8V.

2) TX disable is an input that is used to shut down the transmitter optical output. It is pulled up within the module with a 4.7 – 10 K Ω resistor. Its states are:

Low (0 – 0.8V): Transmitter on

(>0.8, < 2.0V): Undefined

High (2.0 – 3.465V): Transmitter Disabled

Open: Transmitter Disabled

3) Mod-Def 0,1,2. These are the module definition pins. They should be pulled up with a 4.7K – 10KΩ resistor on the host board. The pull-up voltage shall be VccT or VccR (see Section IV for

further details). Mod-Def 0 is grounded by the module to indicate that the module is present  
Mod-Def 1 is the clock line of two wire serial interface for serial ID  
Mod-Def 2 is the data line of two wire serial interface for serial ID

4) LOS (Loss of Signal) is an open collector/drain output, which should be pulled up with a 4.7K – 10KΩ resistor. Pull up voltage between 2.0V and VccT, R+0.3V. When high, this output indicates the received optical power is below the worst-case receiver sensitivity (as defined by the standard in use). Low indicates normal operation. In the low state, the output will be pulled to < 0.8V.

5) VeeR and VeeT may be internally connected within the SFP module.

6) RD-/+: These are the differential receiver outputs. They are AC coupled 100Ω differential lines which should be terminated with 100Ω (differential) at the user SERDES. The AC coupling is done inside the module and is thus not required on the host board. The voltage swing on these lines will be between 370 and 2000 mV differential (185 –1000 mV single ended) when properly terminated.

7) VccR and VccT are the receiver and transmitter power supplies. They are defined as 3.3V ±5% at the SFP connector pin. Maximum supply current is 300mA. Recommended host board power supply filtering is shown below. Inductors with DC resistance of less than 1 ohm should be used in order to maintain the required voltage at the SFP input pin with 3.3V supply voltage. When the recommended supply-filtering network is used, hot plugging of the SFP transceiver module will result in an inrush current of no more than 30mA greater than the steady state value. VccR and VccT may be internally connected within the SFP transceiver module.

8) TD-/+: These are the differential transmitter inputs. They are AC-coupled, differential lines with 100Ω differential termination inside the module. The AC coupling is done inside the module and is thus not required on the host board. The inputs will accept differential swings of 500 – 2400 mV (250 – 1200mV single-ended), though it is recommended that values between 500 and 1200 mV differential (250 – 600mV single-ended) be used for best EMI performance.

## EEPROM

The serial interface uses the 2-wire serial CMOS EEPROM protocol defined for the ATMEL AT24C02/04 family of components. When the serial protocol is activated, the host generates the serial clock signal (SCL). The positive edge clocks data into those segments of the EEPROM that are not write protected within the SFP transceiver. The negative edge clocks data from the SFP transceiver. The serial data signal (SDA) is bi-directional for serial data transfer. The host uses SDA in conjunction with SCL to mark the start and end of serial protocol activation. The memories are organized as a series of 8-bit data words that can be addressed individually or sequentially.

The Module provides diagnostic information about the present operating conditions. The transceiver generates this diagnostic data by digitization of internal analog signals. Calibration and alarm/warning threshold data is written during device manufacture. Received power monitoring, transmitted power monitoring, bias current monitoring, supply voltage monitoring and temperature monitoring all are implemented. The diagnostic data are raw A/D values and must be converted to real world units using calibration constants stored in EEPROM locations 56 – 95 at wire serial bus address A2h. The digital diagnostic memory map specific data field define as following .For detail EEPROM information, please refer to the related document of SFF 8472 Rev 9.3

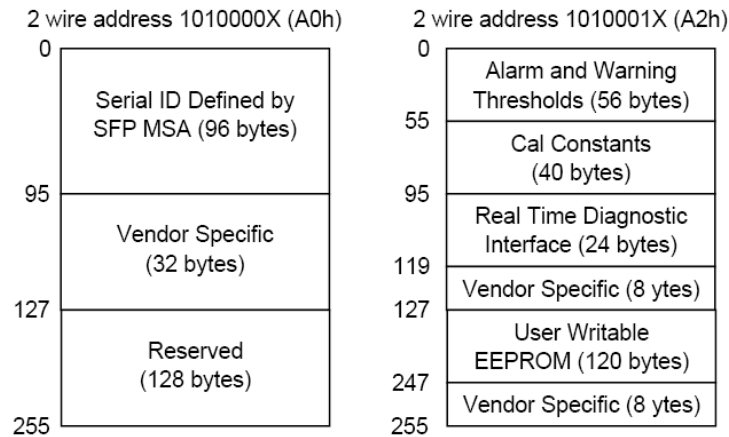

## EEPROM Serial ID Memory Contents

Accessing Serial ID Memory uses the 2 wire address 1010000X (A0). Memory Contents of Serial ID are shown in Table 1.

**Table 1 Serial ID Memory Contents**

| Addr.                 | Size (Bytes) | Name of Field     | Hex  | Description                               |
|-----------------------|--------------|-------------------|--|---|
| <b>BASE ID FIELDS</b> |              |                   |  |   |
| 0                     | 1            | Identifier        | 03   | SFP                                       |
| 1                     | 1            | Ext. Identifier   | 04   | SFP function is defined by serial ID only |
| 2                     | 1            | Connector         | XX   | LC/SC Connector                           |
| 3-10                  | 8            | Transceiver       | 00 00 00 22 00 00 00 00  | Transmitter Code                          |
| 11                    | 1            | Encoding          | 03   | NRZ                                       |
| 12                    | 1            | BR, Nominal       | 06   | 622Mbps                                   |
| 13                    | 1            | Reserved          | 00   |   |
| 14                    | 1            | Length (9μm)km    | 50   | Transceiver transmit distance             |
| 15                    | 1            | Length(9μm)100m   | FF   |   |
| 16                    | 1            | Length (50μm) 10m | 00   |   |
| 17                    | 1            | Length(62.5μm)10m | 00   |   |
| 18                    | 1            | Length (Copper)   | 00   | Not compliant                             |
| 19                    | 1            | Reserved          | 00   |   |
| 20-35                 | 16           | Vendor name       | XX XX XX XX XX XX<br>XX XX <sup>(note9)</sup> 20 20 20<br>20 20 20 20 20 | Vendor name (ASCII)                       |
| 36                    | 1            | Reserved          | 00   |   |
| 37-39                 | 3            | Vendor OUI        | XX XX XX <sup>(note9)</sup>  |   |
| 40-55                 | 16           | Vendor PN         |  | Transceiver part number                   |

|                                  |     |                            |  |  |
|----------------------------------|-----|----------------------------|--|--|
| 56-59                            | 4   | Vendor rev                 | XX XX XX XX <sup>(note9)</sup>   |  |
| 60-61                            | 2   | Wavelength                 | XX XX  | 1310nm/1550nm  |
| 62                               | 1   | Reserved                   | 00   |  |
| 63                               | 1   | CC_BASE                    | Check Sum (Variable)   | Check code for Base ID Fields                                |
| <b>EXTENDED ID FIELDS</b>        |     |                            |  |  |
| 64-65                            | 2   | Options                    | 00 1A  | TX_DISABLE, TX_FAULT and Loss of Signal implemented.         |
| 66                               | 1   | BR,max                     | 00   |  |
| 67                               | 1   | BR,min                     | 00   |  |
| 68-83                            | 16  | Vendor SN                  | XX XX XX XX XX XX<br>XX XX 20 20 20 20 20<br>20 20 20 <sup>(note9)</sup> | Serial Number of transceiver (ASCII). For example "B000822". |
| 84-91                            | 8   | Date code                  | XX XX XX XX XX XX<br>XX XX <sup>(note9)</sup>                            | Manufactory date code. For example "080405".                 |
| 92                               | 1   | Diagnostic Monitoring Type | XX <sup>(note9)</sup>  | Digital diagnostic monitoring implemented                    |
| 93                               | 1   | Enhanced Options           | XX <sup>(note9)</sup>  | Optional flags   |
| 94                               | 1   | SFF_8472 Compliance        | XX <sup>(note9)</sup>  | 01 for diagnostics (Rev9.3 SFF-8472).                        |
| 95                               | 1   | CC_EXT                     | Check Sum (Variable)   | Check sum for Extended ID Field.                             |
| <b>VENDOR SPECIFIC ID FIELDS</b> |     |                            |  |  |
| 96-127                           | 32  | Vendor Specific            | Read only  | Depends on customer information                              |
| 128-255                          | 128 | Reserved                   | Read only  |  |

Note9: The "xx" byte should be filled in according to practical case. For more information, please refer to the related document of SFP Multi-Source Agreement (MSA).

## Recommend Circuit Schematic

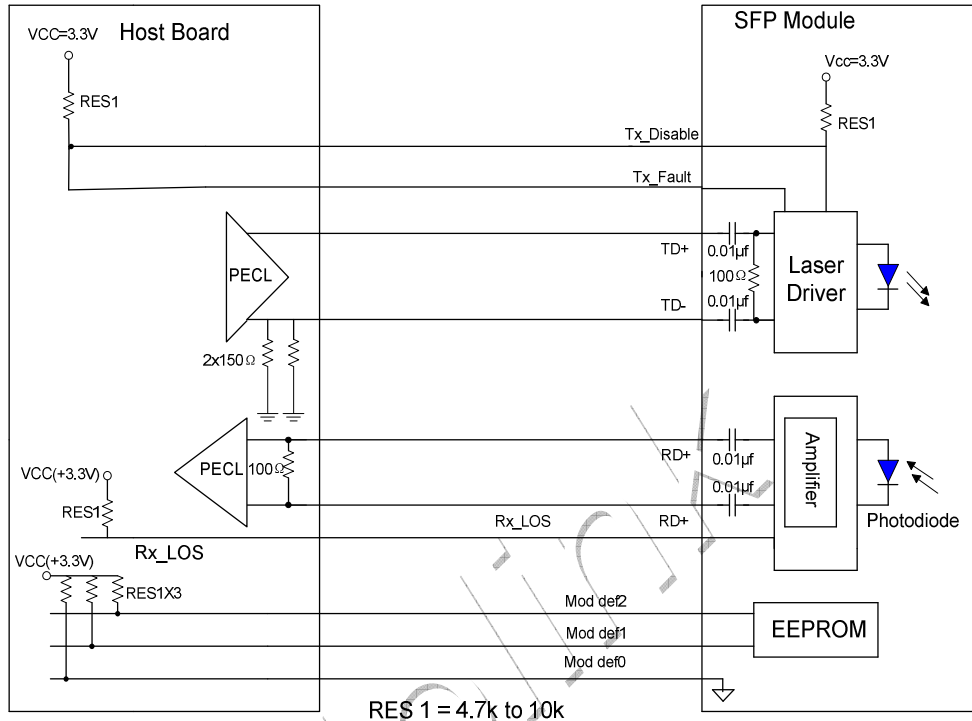

Mechanical Specifications

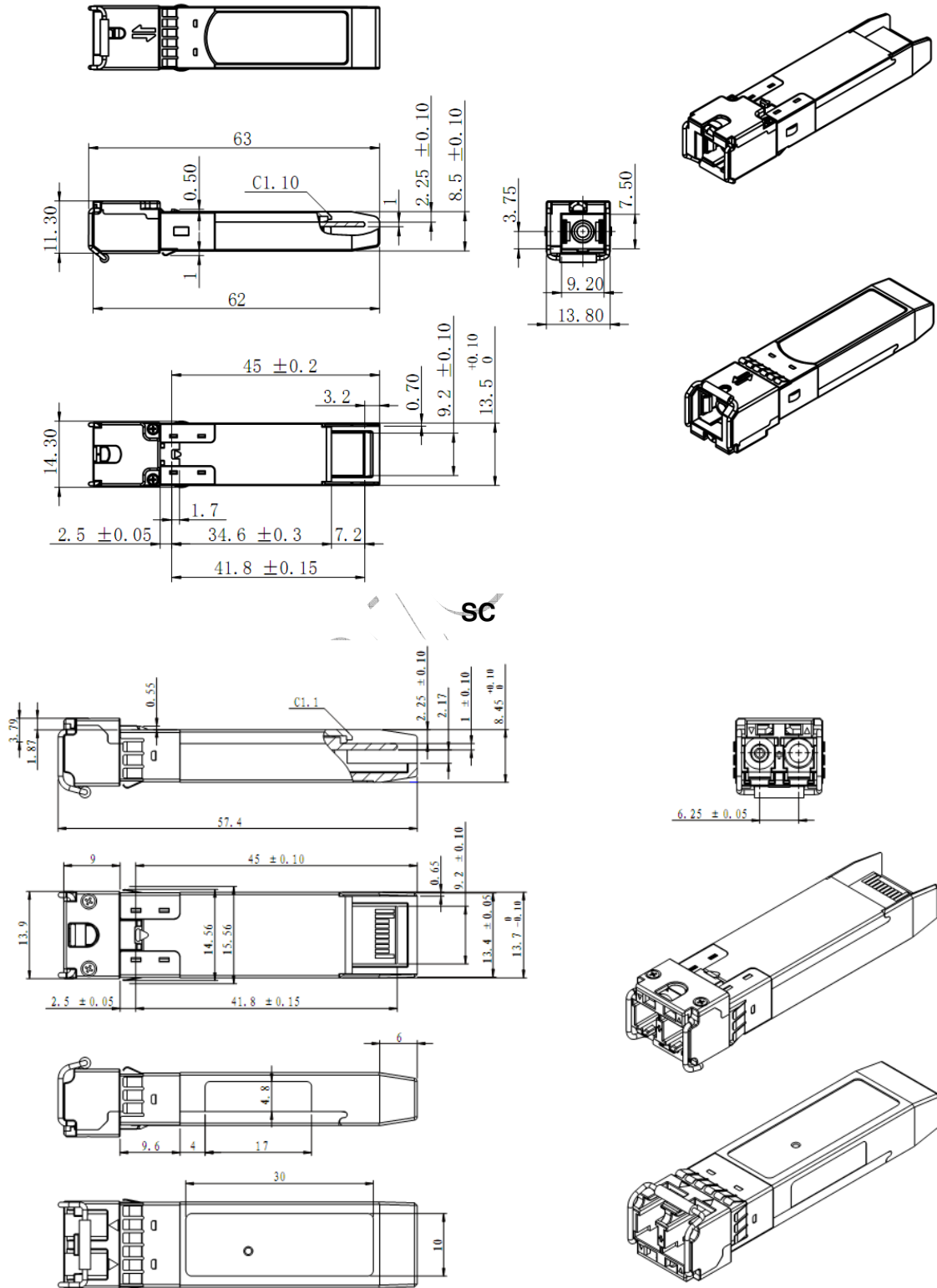

LC

**Class 1 Labels**

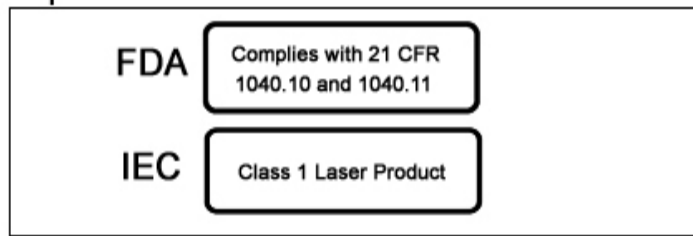

**Laser Emission Data**

|   |          |
|---|----------|
| Wavelength  | 1310nm   |
| Total output power (as defined by FDA: 7 mm aperture at 20 cm distance) | <0.195mW |
| Total output power (as defined by IEC: 7 mm aperture at 10 cm distance) | <15.6mW  |
| Beam divergence   | 12.5°    |
| Wavelength  | 1550nm   |
| Total output power (as defined by FDA: 7 mm aperture at 20 cm distance) | <0.79mW  |
| Total output power (as defined by IEC: 7 mm aperture at 10 cm distance) | <10mW    |
| Beam divergence   | 12.5°    |

**Laser Emission**

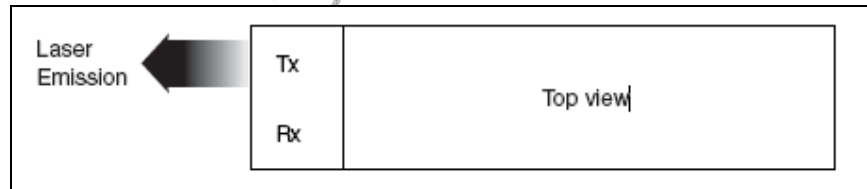

**Obtaining Document**

You can visit our website: <http://www.eoptolink.com>

Or contact Eoptolink Technology Inc., Ltd. listed at the end of the documentation to get the latest documents.

**Revision History**

| Revision | Initiate | Review | Approve | Subject                 | Last printed |
|----------|----------|--------|---------|-------------------------|--------------|
| V1.a     | Tim      | Kelly  |         | Initial datasheet       | Apr 7, 2007  |
| V1.b     | Kelly    |        |         | Update mechanical spec. | Jan 23, 2010 |

**Notice:**

Eoptolink reserves the right to make changes to or discontinue any optical link product or service identified in this publication, without notice, in order to improve design and/or performance. Applications that are described herein for any of the optical link products are for illustrative purposes only. Eoptolink makes no representation or warranty that such applications will be suitable for the specified use without further testing or modification.

**Contact:**

Add: Floor 5 Building 2 No. 21 Gaopeng Avenue High-Tech District CHENGDU, SICHUAN 610041  
P.R. CHINA

Tel: (+86) 028-85122709 ext 816 & 809

Fax: (+86) 028-85121912

Postal: 610041

E-mail: [sales@eoptolink.com](mailto:sales@eoptolink.com)

<http://www.eoptolink.com>

Eoptolink