

EOLX-1396-02

**1310nm XFP Single-Mode for 10GbE/10GFC/SDH/SONET
Duplex XFP Transceiver
RoHS6 Compliant**

Features

- ◆ Supports 9.95Gb/s to 11.1Gb/s bit rates
- ◆ Hot-Pluggable XFP Footprint
- ◆ Distance Up To 2km
- ◆ 1310nm FP Laser
- ◆ Duplex LC Connector
- ◆ Power Dissipation <2.5W
- ◆ Built-in Digital Diagnostic Functions
- ◆ Case Operating Temperature:
0°C to 70°C
- ◆ Complaint with XFP MSA
- ◆ Complaint with IEEE 802.3ae
10GBASE-LR/LW
- ◆ Complaint with 10GFC 1200-SM-LL-L



Applications

- ◆ SONET OC-192 SR-1, SDH STM I-64.1
at 9.953Gbps
- ◆ 10GBASE-LR/LW 10G Ethernet
- ◆ 1200-SM-LL-L 10G Fiber Channel
- ◆ 10GE over G.709 at 11.09Gbps
- ◆ OC192 over FEC at 10.709Gbps

Ordering Information

Part No.	Data Rate	Laser	Fiber Type	Distance	Optical Interface
EOLX-1396-02	10G	FP	SMF	2km	LC

Regulatory Compliance

Feature	Standard	Performance
Electrostatic Discharge (ESD) to the Electrical Pins	MIL-STD-883G Method 3015.7	Class 1C (>1000 V)
Electrostatic Discharge to the enclosure	EN 55024:1998+A1+A2 IEC-61000-4-2 GR-1089-CORE	Compatible with standards
Electromagnetic Interference (EMI)	FCC Part 15 Class B EN55022:2006 CISPR 22B :2006 VCCI Class B	Compatible with standards Noise frequency range: 30MHz to 6GHz. Good system EMI design practice required to achieve Class B margins. System margins are dependent on customer host board and chassis design.
Immunity	EN 55024:1998+A1+A2 IEC 61000-4-3	Compatible with standards. 1kHz sine-wave, 80% AM, from 80 MHz to 1 GHz. No effect on transmitter/receiver performance is detectable between these limits.
Laser Eye Safety	FDA 21CFR 1040.10 and 1040.11 EN (IEC) 60825-1:2007 EN (IEC) 60825-2:2004+A1	CDRH compliant and Class I laser product. TüV Certificate No. 50135086
Component Recognition	UL and CUL EN60950-1:2006	UL file E317337 TüV Certificate No. 50135086 (CB scheme)
RoHS6	2002/95/EC 4.1&4.2 2005/747/EC 5&7&13	Compliant with standards ^{*note2}

Note1: For update of the equipments and strict control of raw materials, EOPTOLINK has the ability to supply the customized products since Jan 1th, 2007, which meet the requirements of RoHS6 (Restrictions on use of certain Hazardous Substances) of European Union.

In light of item 5 in RoHS exemption list of RoHS Directive 2002/95/EC, Item 5: Lead in glass of cathode ray tubes, electronic components and fluorescent tubes.

In light of item 13 in RoHS exemption list of RoHS Directive 2005/747/EC, Item13: Lead and cadmium in optical and filter glass. The three exemptions are being concerned for Eoptolink's transceivers, because Eoptolink's transceivers use glass, which may contain Pb, for components such as lenses, windows, isolators, and other electronic components.

Absolute Maximum Ratings

Parameter	Symbol	Min	Typ	Max	Unit	Ref.
Maximum Supply Voltage 1	Vcc3	-0.5		4.0	V	

Maximum Supply Voltage 2	V _{CC5}	-0.5		6.0	V	
Storage Temperature	T _S	-40		85	°C	
Case Operating Temperature	T _{OP}	0		70	°C	

Recommend operating condition

Parameter	Symbol	Min	Typ	Max	Units
Operating Case Temperature	Top	0		70	°C
Supply Voltage 1	V _{CC3}	3.13		3.45	V
Supply Voltage 2	V _{CC5}	4.75		5.25	V

Electrical Characteristics

(T_{OP} = 0 to 70°C, V_{CC5} = 4.75 to 5.25 Volts)

Parameter	Symbol	Min	Typ	Max	Unit
Main Supply Voltage	V _{CC5}	4.75		5.25	V
Supply Voltage #2	V _{CC3}	3.13		3.45	V
Supply Current – V _{CC5} supply	I _{CC5}			250	mA
Supply Current – V _{CC3} supply	I _{CC3}			500	mA
Transmitter					
Module Total Power	P			2.5	W
Input Differential Impedance	R _{in}		100		Ω
Differential Data Input Swing ^{*2}	V _{in,pp}	120		820	mV
Transmit Disable Voltage	V _D	2.0		V _{CC}	V
Transmit Enable Voltage	V _{EN}	GND		GND+ 0.8	V
Transmit Disable Assert Time				10	us
Receiver					
Differential Data Output Swing ^{*2}	V _{out,pp}	340	650	850	mV
Rise Time (20 – 80%)	t _r			38	ps
Fall Time (20 – 80%)	t _f			38	ps
LOS Fault ^{*3}	V _{LOS fault}	V _{CC} – 0.5		V _{CC} HOST	V
LOS Normal ^{*3}	V _{LOS norm}	GND		GND+0.5	V

Note2. After internal AC coupling.

Note3. Loss of signal is open collector to be pulled up with a 4.7k – 10kohm resistor to 3.15 – 3.6V. Logic 0 indicates normal operation; logic 1 indicates no signal detected.

Optical Characteristics

(T_{OP} = 0 to 70°C, V_{CC5} = 4.75 to 5.25 Volts)

Parameter	Symbol	Min	Typ	Max	Unit
Transmitter					
Optical Output Power	P _O	-5.2		0	dBm
Optical Wavelength	λ _C	1270		1355	nm
Spectrum Width (RMS)	Δλ			3	nm

Optical Extinction Ratio	ER	3.5			dB
Side Mode Suppression ratio	SSR _{min}			30	dB
Average Launch power of OFF transmitter	P _{OFF}			-30	dBm
TX Jitter	T _{xj}	Compliant with each standard requirements			
Receiver					
Receiver Sensitivity @ 10.7Gb/s	P _{min}			-14.4	dBm
Maximum Input Power	P _{max}	+0.5			dBm
Optical Center Wavelength	λ _c	1260		1565	nm
Receiver Reflectance	R _{rx}			-14	dB
LOS De-Assert	LOSD			-15	dBm
LOS Assert	LOSA	-25			dBm
LOS Hysteresis		1			dB

Pin Descriptions

Pin	Symbol	Name/Description	Note
1	GND	Module Ground	4
2	VEE5	Optional -5.2 Power Supply – Not required	
3	Mod-Desel	Module De-select; When held low allows the module to respond to 2-wire serial interface commands	
4	Interrupt	Interrupt (bar); Indicates presence of an important condition which can be read over the serial 2-wire interface	5
5	TX_DIS	Transmitter Disable; Transmitter laser source turned off	
6	VCC5	+5 Power Supply	
7	GND	Module Ground	4
8	VCC3	+3.3V Power Supply	
9	VCC3	+3.3V Power Supply	
10	SCL	Serial 2-wire interface clock	5
11	SDA	Serial 2-wire interface data line	5
12	Mod_Abs	Module Absent; Indicates module is not present. Grounded in the module.	5
13	Mod_NR	Module Not Ready;	5
14	RX_LOS	Receiver Loss of Signal indicator	5
15	GND	Module Ground	4
16	GND	Module Ground	4
17	RD-	Receiver inverted data output	
18	RD+	Receiver non-inverted data output	
19	GND	Module Ground	4
20	VCC2	+1.8V Power Supply – Not required	

21	P_Down/RST	Power Down; When high, places the module in the low power stand-by mode and on the falling edge of P_Down initiates a module reset	
		Reset; The falling edge initiates a complete reset of the module including the 2-wire serial interface, equivalent to a power cycle.	
22	VCC2	+1.8V Power Supply – Not required	
23	GND	Module Ground	4
24	RefCLK+	Reference Clock non-inverted input, AC coupled on the host board – Not required	6
25	RefCLK-	Reference Clock inverted input, AC coupled on the host board – Not required	6
26	GND	Module Ground	4
27	GND	Module Ground	4
28	TD-	Transmitter inverted data input	
29	TD+	Transmitter non-inverted data input	
30	GND	Module Ground	4

Note4. Module circuit ground is isolated from module chassis ground within the module.

Note5. Open collector; should be pulled up with 4.7k – 10k ohms on host board to a voltage between 3.15V and 3.6V.

Note6. A Reference Clock input is not required.

Pin arrangement

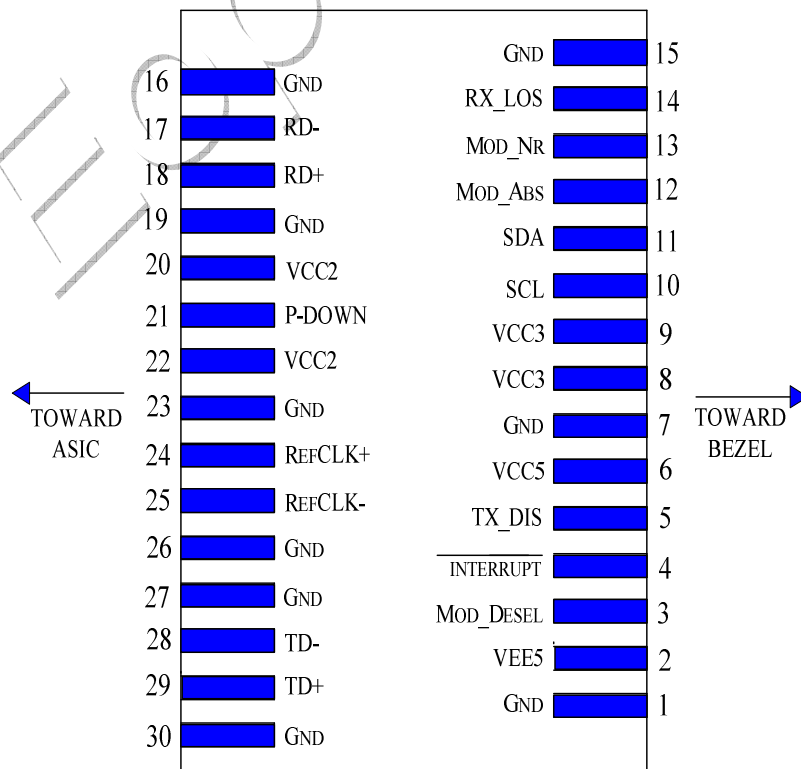

Pin Numbers and Name

General Specifications

Parameter	Symbol	Min	Typ	Max	Units	Ref.
Bit Rate	BR	9.95		11.1	Gb/s	1
Bit Error Ratio	BER			10^{-12}		2
Max. Supported Link Length	LMAX		10		km	1

Notes:

1. SONET OC-192 SR-1, SDH STM I-64.1, 10GBASE-LR/LW, 1200-SM-LL-L
2. Tested with a $2^{31} - 1$ PRBS

Digital Diagnostic Functions

Eoptolink's EOLX-1396-02 Small Form Factor 10Gbps (XFP) transceivers are compliant with the current XFP Multi-Source Agreement (MSA) Specification Rev 4.5.

As defined by the XFP MSA, Eoptolink XFP transceivers provide digital diagnostic functions via a 2-wire serial interface, which allows real-time access to the following operating parameters:

- ◆ Transceiver temperature
- ◆ Laser bias current
- ◆ Transmitted optical power
- ◆ Received optical power
- ◆ Transceiver supply voltage

It also provides a sophisticated system of alarm and warning flags, which may be used to alert end-users when particular operating parameters are outside of a factory-set normal range.

The operating and diagnostics information is monitored and reported by a Digital Diagnostics Transceiver Controller inside the transceiver, which is accessed through the 2-wire serial interface. When the serial protocol is activated, the serial clock signal (SCL pin) is generated by the host. The positive edge clocks data into the XFP transceiver into those segments of its memory map that are not write-protected. The negative edge clocks data from the XFP transceiver. The serial data signal (SDA pin) is bi-directional for serial data transfer. The host uses SDA in conjunction with SCL to mark the start and end of serial protocol activation. The memories are organized as a series of 8-bit data words that can be addressed individually or sequentially. The 2-wire serial interface provides sequential or random access to the 8 bit

parameters, addressed from 000h to the maximum address of the memory.

Recommended Host Board Power Supply Circuit

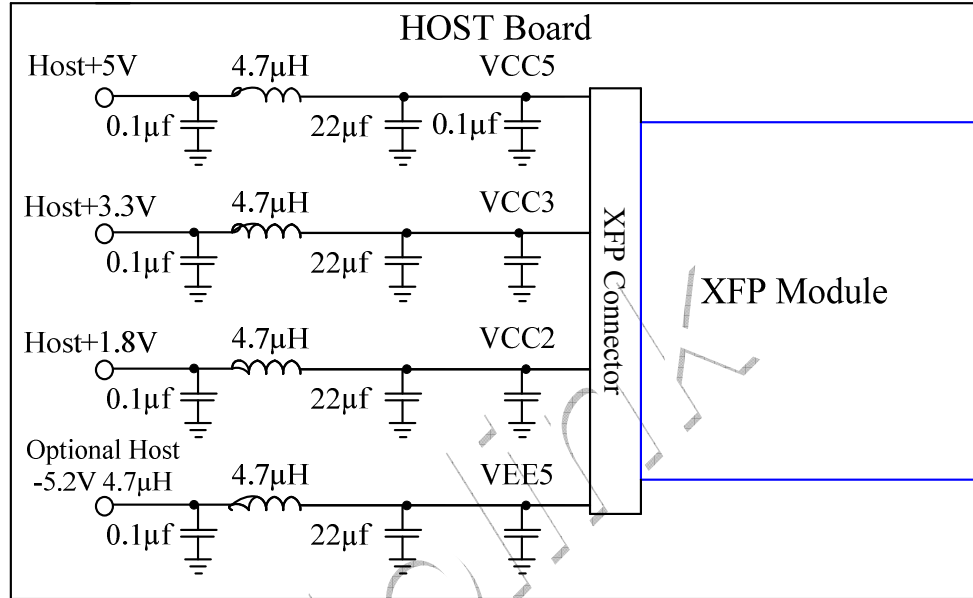

Recommended High-speed Interface Circuit

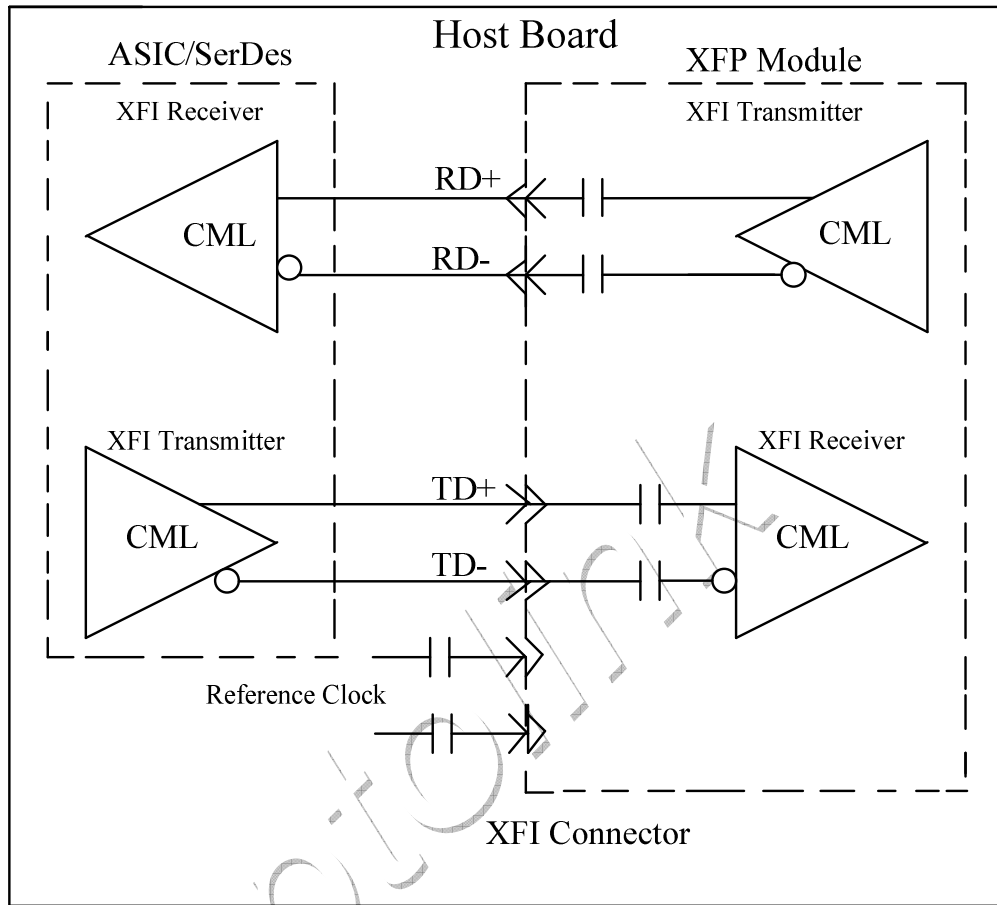

Mechanical Specifications

Eoptolink's XFP transceivers are compliant with the dimensions defined by the XFP Multi-Sourcing Agreement (MSA).

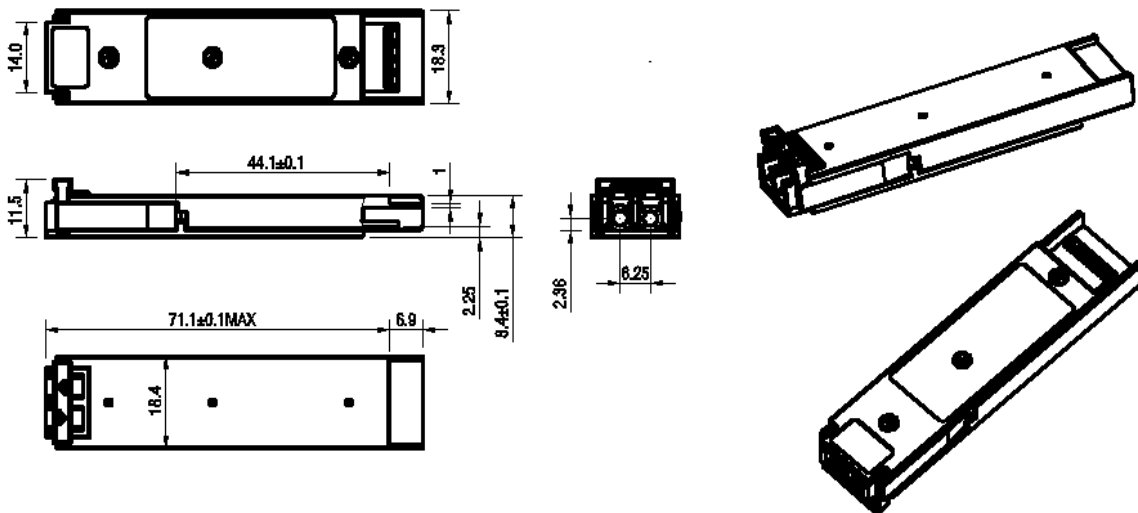

Eye Safety

This single-mode transceiver is a Class 1 laser product. It complies with IEC-60825 and FDA 21 CFR 1040.10 and 1040.11. The transceiver must be operated within the specified temperature and voltage limits. The optical ports of the module shall be terminated with an optical connector or with a dust plug.

Obtaining Document

You can visit our website:

<http://www.eoptolink.com>

Or contact Eoptolink Technology Inc., Ltd. listed at the end of the documentation to get the latest documents.

Revision History

Revision	Initiated	Reviewed	Approved	DCN	Release Date
V1.a	Kelly.Cao	Tim.Liang		Released.	Sep 26, 2007
V1.b	Cathy.Chen	Kelly.Cao		Revise sensitivity description & delete item7 in note1.	Dec 30, 2009
V1.c	Kelly.Cao			Change the logo.	Jan 4, 2010

Notice:

Eoptolink reserves the right to make changes to or discontinue any optical link product or service identified in this publication, without notice, in order to improve design and/or performance. Applications that are described herein for any of the optical link products are for illustrative purposes only. Eoptolink makes no representation or warranty that such applications will be suitable for the specified use without further testing or modification.

Contact:

Add: Floor 5, Building 2, No. 21 Gaopeng Avenue, High-Tech District, CHENGDU, SICHUAN 610041 P.R. CHINA

Tel: (+86) 028-85122709 ext 816 & 809

Fax: (+86) 028-85121912

Postal: 610041

E-mail:sales@eoptolink.com

<http://www.eoptolink.com>