

EOLX-8596-02X

**850nm XFP Multi-Mode for 10GbE/10GFC
Duplex XFP Transceiver
RoHS6 Compliant**

Features

- ◆ Fully compliant to XFP MSA Rev.4.5
- ◆ Support of IEEE 802.3ae 10GBASE-SR at 10.3125 Gbit/s
- ◆ Compliance to Fiber Channel 1200-M5-SN-I, 1200-M5E-SN-I, 1200-M6-SN-I at 10.51875Gbit/s
- ◆ Transmission distance up to 300m with OM3 MMF
82m with OM2 MMF
33m with OM1 MMF
- ◆ Low power consumption 1.5W(typ.)
- ◆ Wide operating temperature range:
Standard: 0C to +70C
Industrial: -40C to +85C
- ◆ Laser Class 1M compliant
- ◆ Vertical Cavity Surface Emitting Laser at 850nm(VCSEL)
- ◆ LC duplex connector
- ◆ XFI loopback supported
- ◆ Lead free and RoHS Compliant
- ◆ Excellent EMI performance
- ◆ High reliability



Ordering information

Part No.	Data Rate	Laser	Fiber Type	Distance	Optical Interface	Temperature range
EOLX-8596-02	10G	VCSEL	MMF	300m	LC	0C~70C
EOLX-8596-02I	10G	VCSEL	MMF	300m	LC	-40C~85C

Regulatory Compliance

Feature	Standard	Performance
Electrostatic Discharge (ESD) to the Electrical Pins	MIL-STD-883G Method 3015.7	Class 1C (>1000 V)
Electrostatic Discharge to the enclosure	EN 55024:1998+A1+A2 IEC-61000-4-2 GR-1089-CORE	Compatible with standards
Electromagnetic Interference (EMI)	FCC Part 15 Class B EN55022:2006 CISPR 22B :2006 VCCI Class B	Compatible with standards Noise frequency range: 30 MHz to 6 GHz. Good system EMI design practice required to achieve Class B margins. System margins are dependent on customer host board and chassis design.
Immunity	EN 55024:1998+A1+A2 IEC 61000-4-3	Compatible with standards. 1kHz sine-wave, 80% AM, from 80 MHz to 1 GHz. No effect on transmitter/receiver performance is detectable between these limits.
Laser Eye Safety	FDA 21CFR 1040.10 and 1040.11 EN (IEC) 60825-1:2007 EN (IEC) 60825-2:2004+A1	CDRH compliant and Class I laser product. TüV Certificate No. 50135086
Component Recognition	UL and CUL EN60950-1:2006	UL file E317337 TüV Certificate No. 50135086 (CB scheme)
RoHS6	2002/95/EC 4.1&4.2 2005/747/EC 5&7&13	Compliant with standards ^{*note1}

Note1: For update of the equipments and strict control of raw materials, EOPTOLINK has the ability to supply the customized products since Jan 1th, 2007, which meet the requirements of RoHS6 (Restrictions on use of certain Hazardous Substances) of European Union.

In light of item 5 in RoHS exemption list of RoHS Directive 2002/95/EC, Item 5: Lead in glass of cathode ray tubes, electronic components and fluorescent tubes.

In light of item 13 in RoHS exemption list of RoHS Directive 2005/747/EC, Item13: Lead and cadmium in optical and filter glass. The three exemptions are being concerned for Eoptolink's transceivers, because Eoptolink's transceivers use glass, which may contain Pb, for components such as lenses, windows, isolators, and other electronic components.

General Description and Applications

The EOLX-8596-02 is a multi-purpose optical transceiver module for 10Gbit/s data transmission

applications at 850nm. It is ideally suited for 10 GbE datacom (belly-to-belly for high density applications) and storage area network(SAN/NAS) applications based on the IEEE 802.3ae and Fibre Channel standards Designed for short range distances the transceiver module comprises a transmitter with a vertical cavity surface emitting laser (VCSEL) and a receiver with a PIN photodiode. Transmitter and receiver are separate within a wide temperature range and offers optimum heat dissipation and excellent electromagnetic shielding thus enabling high port densities for 10 GbE systems.

Standard	Description	Nominal Baud Rate	Unit
IEEE 802.3ae-2002	10 GBASE-SR	10.3125	GBd
1200-Mxx-SN-I	10G Fiber Channel	10.51875	GBd

Electrical Characteristics

Absolute Maximum Ratings

Rating	Conditions	Symbol	Min	Max	Units
Storage Ambient Temperature Range			-40	+85	°C
Powered case Temperature Range	EOLX-8596-02	T _A	0	+70	°C
	EOLX-8596-02I		-40	+85	
Operating Relative Humidity		RH	8	80	%
Supply Voltage Range @ 5.0V		V _{CC5}	0.5	6.0	V
Supply Voltage Range @ 3.3V		V _{CC3}	0.5	3.6	V
Open Drain VCC level		V _{OD}		4.0	V
Static Discharge Voltage on XFI High	HBM human body model per JEDEC JESD22-A114-B			500	V
Static Discharge Voltage excluding XFI High Speed Pins	HBM human body model			2,000	V
Static Discharge Voltage on XFP Module	EN61000-4-2 Criterion B: Air Discharge Direct Contact discharge			15,000	V
				8,000	V

Any stress beyond the maximum ratings can result in permanent damage. The device

specifications are guaranteed only under the recommended operating conditions

Recommend operating condition

Parameter	Conditions	Symbol	Min	Typ	Max	Units
Operating Case Temperature Range	EOLX-8596-02X	T_A	0		+70	°C
	EOLX-8596-02IX		-40		+85	
Transceiver total Power Consumption		P_{TOT}		1.5	2.3	W
Power Supply Voltage @ 5.0V		V_{CC5}	4.75	5.00	5.25	V
Power Supply Voltage @ 3.3V		V_{CC3}	3.135	3.300	3.465	V
Supply Current	@ V_{CC5}	I_{VCC5}		50	100	mA
Supply Current	@ V_{CC3}	I_{VCC3}		325	500	mA

High Speed Line Characteristics

Parameter	Conditions	Symbol	Min	Typ	Max	Units
Baud Rate nominal			9.95		10.71	Gbd
Baud Rate Tolerance			-100		+100	ppm

High Speed Line Output-DC Characteristics

Parameter	Conditions	Symbol	Min	Typ	Max	Units
Single Ended Output Impedance		Z_{SE}	40	50	60	Ω
Differential Output Impedance		Z_{OD}	80	100	120	Ω

High Speed Line Output-AC Characteristics

Parameter	Conditions	Symbol	Min	Typ	Max	Units
Differential Output Amplitude		V_{OSPP}	340		850	mV
Output Common Mode		V_{CM}	0		3.6	V
Transition Time Low to High		t_r	24			ps

Transition Time High to Low		t_f	24			ps
Differential Output Return Loss	0.05—0.1GHz 0.1—5.5GHz 5.5—12GHz		20 8 See1)			dB dB
Common Mode Output Return $Loss^2$)	0.1—15GHz	SCC 22	3			dB
Total Peak-to-peak Jitter		D_j			0.34	UI
Output AC Common Mode Voltage					15	mV (RMS)

- 1) $SDD22(dB)=8-20.66 \log_{10}(f15.5)$ with f in GHz
- 2) Common mode reference impedance is 25Ω . Common mode return loss helps absorb reflection and noise improving EMI.

High Speed Line Input-DC Characteristics

Parameter	Conditions	Symbol	Min	Typ	Max	Units
Differential Output Impedance		R_{IND}	80	100	120	Ω
Input AC Common Mode Input Voltage			0		25	mV (RMS)
Source to Sink DC Potential Difference		V_{CM}	0		3.6	V

High Speed Line Input-AC Characteristics

Parameter	Conditions	Symbol	Min	Typ	Max	Units
Differential input Voltage Swing		V_{ID}	120 See 2)			mV
Differential Return Loss	0.05—0.1GHz 0.1—5.5GHz 5.5—12GHz	SDD11	20 8 See 1)			dB
Common Mode Return Loss	0.1—15GHz	SCC11	3			dB
Total Jitter		T_j			TBD	UI

- 1) $SDD11(dB)=8-20.66 \log_{10}(f15.5)$ with f in GHz
- 2) Beneath this level the signal can't meet the specification

Optical Transmitter

Parameter	Conditions	Symbol	Min	Typ	Max	Units
Nominal Wavelength		λ_{TRP}	840	850	860	nm
Spectral Width		$\Delta\lambda$		0.4	0.45	nm
Operating Range	62.5/125 μ m MMF	160	I_{OP}	2		26
	50/125 μ m MMF	400		2		66
	62.5/125 μ m MMF	200		2		33
	50/125 μ m MMF	500		2		82
	50/125 μ m MMF	2000		2		300
Nominal Signalling Speed			f_{OPT}	9.95		10.71
Average Launch Power		P_o	-7.3	-2.6	-1	dBm
Extinction Ratio		ER	3.5	5.5		dB
Relative Intensity Noise		RIN			-128	dB/Hz

Optical Receiver

Parameter	Conditions	Symbol	Min	Typ	Max	Units
Center Wavelength		λ_c	840	850	860	nm
Receiver Sensitivity	BER 10^{-12} @ $2^{31} - 1$ ¹⁾	P_{IN}		-13.5	-11.1	dBm
Stressed Receiver Sensitivity	in OMA	P_{IN}			-7.5	dBm
Saturation Input Power		P_{SAT}			1	dBm

1) With ideal transmitter

Note: The specified characteristics are met within the recommended range of operating conditions and under the default settings of output power and modulation amplitude.. A change in setting of the optical output power influences especially the dynamic behavior of the output signal. Unless otherwise noted typical data are quoted at nominal voltages and +25°C ambient temperature.

Hostboard Connector Pinout

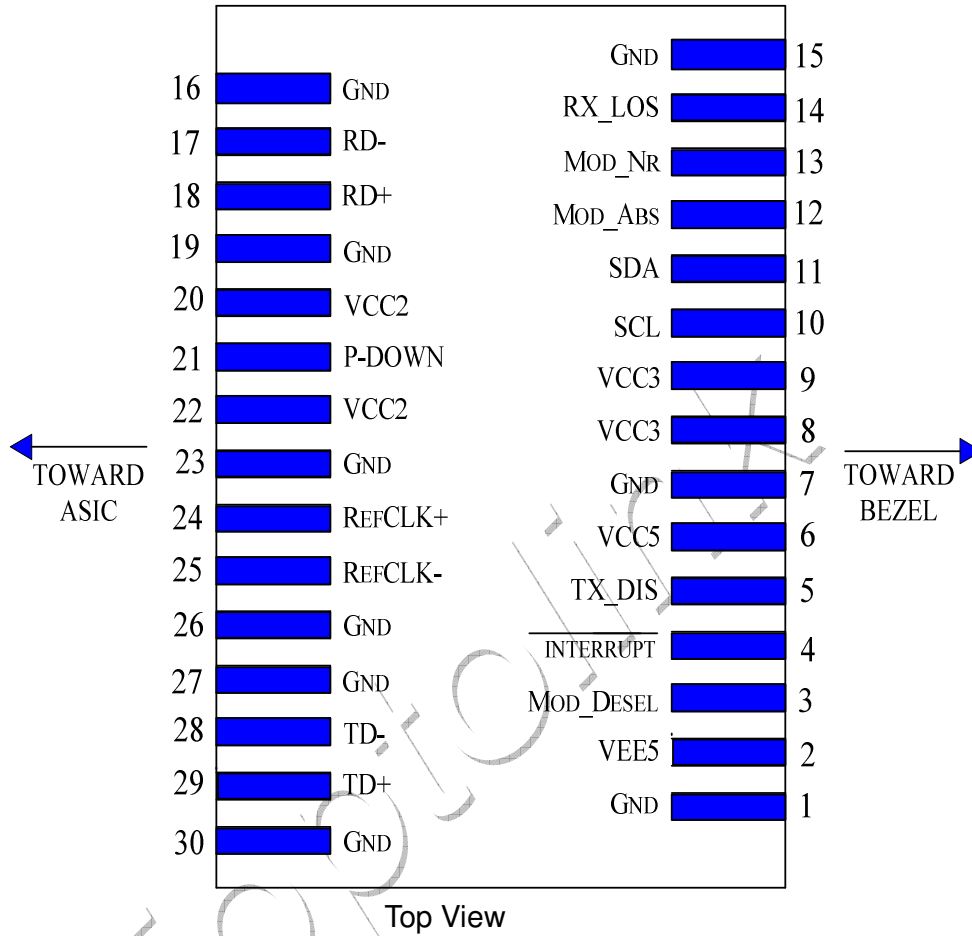

Electrical Pin Definition

PIN	Logic	Symbol	Name Description	Note
1		GND	Module Ground	1
2		VEE5	Optional-5.2V Power Supply	
3	LVTTL-I	Mod_DeSel	Mode De-select; When held low allows module to 2-wire serial interface commands	
4	LVTTL-O	Interrupt	Interrupt(inverted); Indicates Presence of an important condition which can be read over the 2-wire serial interface	2
5	LVTTL-I	TX_DS	Transmitter Disable; Turns off transmitter laser output	
6		VCC5	+5V Power Supply	
7		GND	Module Ground	1
8		VCC3	+3.3V Power Supply	
9		VCC3	+3.3V Power Supply	
10	LVTTL-I/O	SCL	2-Wire Serial Interface Clock	2

11	LVTTL-I/O	SDA	2-Wire Serial Interface Data Line	2
12	LVTTL-O	Mod_Abs	Indicates Module is not present. Grounded in the module	2
13	LVTTL-O	Mod_NR	Module Not Ready; Indicating module operational fault	2
14	LVTTL-O	RX_LOS	Receiver Loss Of Signal Indicator	2
15		GND	Module Ground	1
16		GND	Module Ground	1
17	CML-O	RD-	Receiver Inverted Data Output	
18	CML-O	RD+	Receiver Non-Inverted Data Output	
19		GND	Module Ground	1
20		VCC2	+1.8V Power Supply	
21	LVTTL-O	P-Down/RST	Power Down; When high; requires the module to limit power consumption to 1.5W or below. 2-Wire serial interface must be functional in the low Power mode Reset; The falling edge initiates a complete reset of the module including the 2-wire serial interface; equivalent to a power cycle	
22		VCC2	+1.8V Power Supply	
23		GND	Module Ground	1
24	PECL-I	RefCLK+	Reference Clock Non-Inverted Input; AC coupled on the host board	
25	PECL-I	RefCLK-	Reference Clock Inverted Input; AC coupled on the host board	
26		GND	Module Ground	1
27		GND	Module Ground	1
28	CML-I	TD-	Transmitter Inverted Data Input	
29	CML-I	TD+	Transmitter Non-Inverted Data Input	
30		GND	Module Ground	1

- 1) Module ground pins GND are isolated from the module case and chassis ground within the module.
- 2) Shall be pulled up with 4.7k Ω -10 k Ω to a voltage between 3.15V and 3.45V on the host board.

Digital Diagnostic Functions

Eoptolink's EOLX-8596-02 Small Form Factor 10Gb/s (XFP) transceivers are compliant with the current XFP Multi-Source Agreement (MSA) Specification Rev 4.5.

As defined by the XFP MSA, Eoptolink XFP transceivers provide digital diagnostic functions via a 2-wire serial interface, which allows real-time access to the following operating parameters:

- ◆ Transceiver temperature
- ◆ Laser bias current
- ◆ Transmitted optical power
- ◆ Received optical power
- ◆ Transceiver supply voltage

It also provides a sophisticated system of alarm and warning flags, which may be used to alert end-users when particular operating parameters are outside of a factory-set normal range.

The operating and diagnostics information is monitored and reported by a Digital Diagnostics Transceiver Controller inside the transceiver, which is accessed through the 2-wire serial interface. When the serial protocol is activated, the serial clock signal (SCL pin) is generated by the host. The positive edge clocks data into the XFP transceiver into those segments of its memory map that are not write-protected. The negative edge clocks data from the XFP transceiver. The serial data signal (SDA pin) is bi-directional for serial data transfer. The host uses SDA in conjunction with SCL to mark the start and end of serial protocol activation. The memories are organized as a series of 8-bit data words that can be addressed individually or sequentially. The 2-wire serial interface provides sequential or random access to the 8 bit parameters, addressed from 000h to the maximum address of the memory.

Mechanical Specifications

Eoptolink's XFP transceivers are compliant with the dimensions defined by the XFP Multi-Sourcing Agreement (MSA).

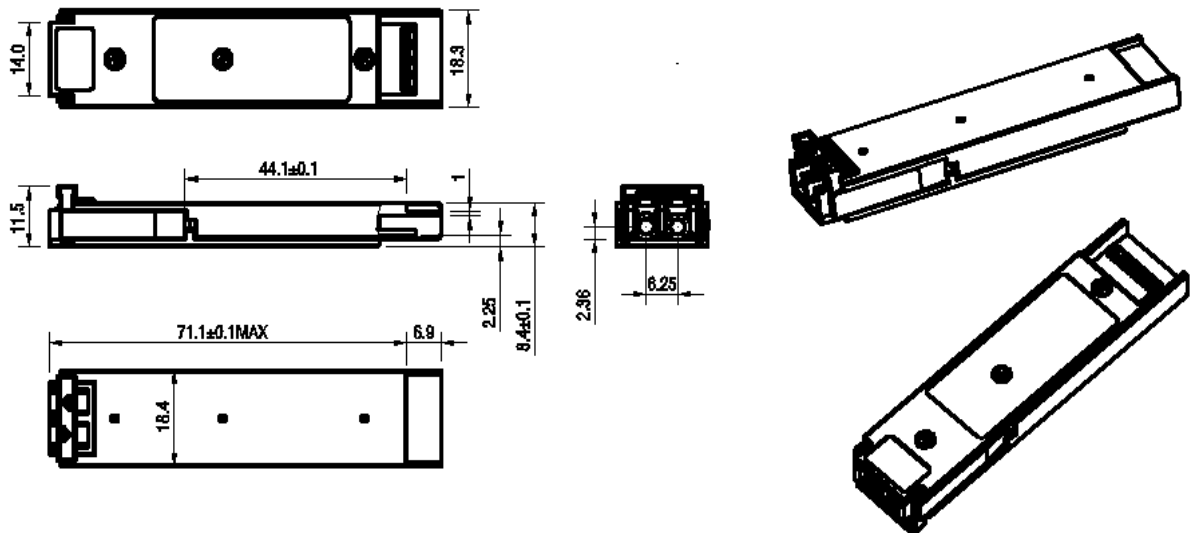

Recommended Host Board Power Supply Circuit

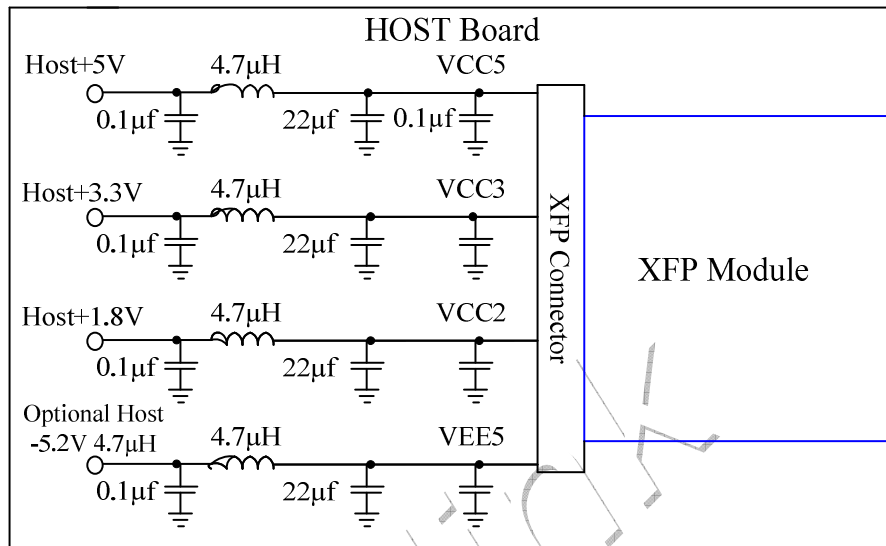

Recommended High-speed Interface Circuit

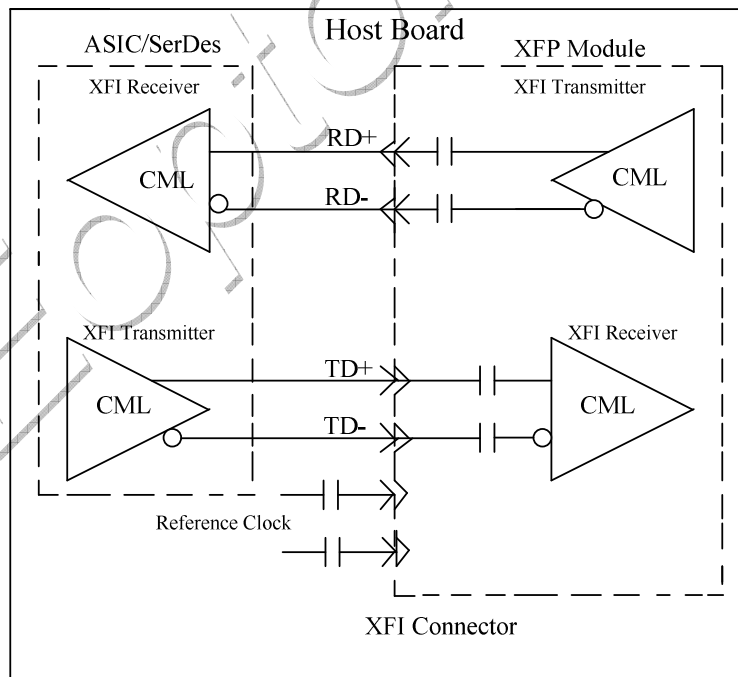

Eye Safety

This laser based multimode transceiver is a Class 1M product. It complies with IEC 60825-1 and FDA performance standards for laser products (21 CFR1040.10 and 1040.11)except for deviations pursuant to laser Notice 50.dated July 26.2001.

CLASS 1M LASER PRODUCT DO NOT VIEW DIRECTLY WITH OPTICAL INSTRUMENTS

To meet laser safety requirements the transceiver shall be operated within Absolute Maximum Ratings.

Note: All adjustments have been made at the factory prior to shipment of the devices No maintenance or alteration to the device is required. Tampering with or modifying the performance of the device will result in voided product warranty. Failure to adhere to the above restrictions could result in a modification that is considered an act of “manufacturing”, and will require, under law, recertification of the modified product with the U.S. Food and Drug Administration (ref.21 CFR 1040.10(1)).

Obtaining Document

You can visit our website:

<http://www.eoptolink.com>

Or contact Eoptolink Technology Inc., Ltd. listed at the end of the documentation to get the latest documents.

Revision History

Revision	Initiate	Review	Approve	Revision History	Last printed
V1.a	Tim.Liang	Kelly.Cao Florence.Dai	Richard.Huang	Released.	Dec 22.2007
V1.b	Jacky	Kelly		Delete the item7 in Note1.	June 19, 2009
V1.c	Kelly			Revise the sensitivity description.	Dec 31, 2009
V1.d	Kelly			Change the logo.	Jan 4, 2010

Notice:

Eoptolink reserves the right to make changes to or discontinue any optical link product or service identified in this publication, without notice, in order to improve design and/or performance. Applications that are described herein for any of the optical link products are for illustrative purposes only. Eoptolink makes no representation or warranty that such applications will be suitable for the specified use without further testing or modification.

Contact:

Add: Floor 5 Building 2 No. 21 Gaopeng Avenue High-Tech District CHENGDU, SICHUAN
610041 P.R. CHINA

Tel: (+86) 028-85122709 ext 816 & 809

Fax: (+86) 028-85121912

Postal: 610041

E-mail: sales@eoptolink.com

<http://www.eoptolink.com>

Eoptolink