

EOLX-1596-80X

1550nm XFP Single-Mode for 10GbE/10GFC/SDH/SONET
 Duplex XFP Transceiver
 RoHS6 Compliant

Features

- ◆ Supports 9.95Gb/s to 11.1Gb/s Bit Rates
- ◆ Hot-pluggable XFP Footprint
- ◆ Maximum Link Length up to 80km
- ◆ Temperature-Stabilized EML transmitter
- ◆ Duplex LC Connector
- ◆ Power Dissipation <3.5W
- ◆ Built-in Digital Diagnostic Functions
- ◆ Case Operating Temperature:
 - Standard: 0°C to 70°C
 - Industrial: -40 to 85°C
- ◆ No external clock required



Applications

- ◆ 10GBASE-ZR 10G Ethernet
- ◆ 1200-SM-LL-L 10G Fiber Channel
- ◆ SONET OC-192 IR-2
- ◆ SDH STM S-64.2b
- ◆ SONET OC-192 IR-3
- ◆ SDH STM S-64.3b
- ◆ ITU-T G.709

Ordering Information

Part No.	Data Rate	Laser	Fiber Type	Distance	Optical Interface	Temp.
EOLX-1596-80	10Gbps	EML	SMF	80km	LC	Standard
EOLX-1596-80I	10Gbps	EML	SMF	80km	LC	Industrial

Regulatory Compliance

Feature	Standard	Performance
Electrostatic Discharge (ESD) to the Electrical Pins	MIL-STD-883G Method 3015.7	Class 1C (>1000 V)
Electrostatic Discharge to the enclosure	EN 55024:1998+A1+A2 IEC-61000-4-2 GR-1089-CORE	Compatible with standards
Electromagnetic Interference (EMI)	FCC Part 15 Class B EN55022:2006 CISPR 22B :2006 VCCI Class B	Compatible with standards Noise frequency range: 30MHz to 6GHz. Good system EMI design practice required to achieve Class B margins. System margins are dependent on customer host board and chassis design.
Immunity	EN 55024:1998+A1+A2 IEC 61000-4-3	Compatible with standards. 1KHz sine-wave, 80% AM, from 80MHz to 1GHz. No effect on transmitter/receiver performance is detectable between these limits.
Laser Eye Safety	FDA 21CFR 1040.10 and 1040.11 EN (IEC) 60825-1:2007 EN (IEC) 60825-2:2004+A1	CDRH compliant and Class I laser product. TüV Certificate No. 50135086
Component Recognition	UL and CUL EN60950-1:2006	UL file E317337 TüV Certificate No. 50135086 (CB scheme)
RoHS6	2002/95/EC 4.1&4.2 2005/747/EC 5&7&13	Compliant with standards ^{*note2}

Note1: For update of the equipments and strict control of raw materials, EOPTOLINK has the ability to supply the customized products since Jan 1, 2007, which meet the requirements of RoHS6 (Restrictions on use of certain Hazardous Substances) of European Union.

In light of item 5 in RoHS exemption list of RoHS Directive 2002/95/EC, Item 5: Lead in glass of cathode ray tubes, electronic components and fluorescent tubes.

In light of item 13 in RoHS exemption list of RoHS Directive 2005/747/EC, Item13: Lead and cadmium in optical and filter glass. The three exemptions are being concerned for Eoptolink's transceivers, because Eoptolink's transceivers use glass, which may contain Pb, for components such as lenses, windows, isolators, and other electronic components.

Absolute Maximum Ratings^{*2}

Parameter	Symbol	Min	Typ	Max	Unit
Maximum Supply Voltage 1	V _{cc3}	-0.5	-	4.0	V
Maximum Supply Voltage 2	V _{cc5}	-0.5	-	6.0	V
Storage Temperature	T _s	-40	-	85	°C
Case Operating Temperature, EOLX-1596-80	T _{OP}	0	-	70	°C
Case Operating Temperature, EOLX-1596-80I	T _{OP}	-40	-	85	°C
Maximum Input Power	P _m			-8	dBm

Note2: Exceeding any one of these values may destroy the device permanently.

Recommended Operating Condition

Parameter	Symbol	Min	Typ	Max	Units
Supply Voltage 1	V _{cc3}	3.13	3.3	3.45	V
Supply Voltage 2	V _{cc5}	4.75	5	5.25	V

Electrical Characteristics

Parameter	Symbol	Min	Typ	Max	Unit
Main Supply Voltage	V _{cc5}	4.75	-	5.25	V
Supply Voltage #2	V _{cc3}	3.13	-	3.45	V
Supply Current – V _{cc5} supply	I _{cc5}	-	-	300	mA
Supply Current – V _{cc3} supply	I _{cc3}	-	-	750	mA
Module Total Power	P	-	-	3.5	W
Transmitter					
Input Differential Impedance ^{*3}	R _{in}	-	100	-	Ω
Differential Data Input Swing	V _{in,pp}	120	-	820	mV
Transmit Disable Voltage	V _D	2.0	-	V _{cc}	V
Transmit Enable Voltage	V _{EN}	GND	-	GND+ 0.8	V
Transmit Disable Assert Time		-	-	10	us
Receiver					
Differential Data Output Swing ^{*3}	V _{out,pp}	340	650	850	mV
Rise Time (20– 80%)	t _r	-	-	38	ps
Fall Time (20– 80%)	t _f	-	-	39	ps
LOS Fault ^{*4}	V _{LOS fault}	V _{cc} – 0.5	-	V _{cc} HOST	V
LOS Normal ^{*4}	V _{LOS norm}	GND	-	GND+0.5	V

Note3. After internal AC coupling

Note4. Loss of signal is open collector. Logic 0 indicates normal operation; logic 1 indicates no signal detected.

Optical Characteristics

Parameter	Symbol	Min	Typ	Max	Unit
Transmitter					
Output Power @ 9/125 SMF	P _{out}	0	-	+4	dBm
Optical Wavelength	λ_C	1530	-	1565	nm
Spectral Width (-20dB)	$\Delta\lambda$	-	-	1	nm
Optical Extinction Ratio	ER	8.2	-	-	dB
Average Launch Power of OFF Transmitter	P _{OFF}	-	-	-30	dBm
TX Jitter Generation (Peak-to-Peak)	T _{Xj}	-	-	0.1	UI
TX Jitter Generation (RMS)	T _{XjRMS}	-	-	0.01	UI
Relative Intensity Noise	RIN	-	-	-130	dB/Hz
Eye Mask		Compliant with ITU-T G.691			
Receiver					
Receiver Sensitivity@ 9.95Gb/s ^{*5}	P _{min}	-	-	-24	dBm
Receiver Sensitivity @ 10.7Gb/s ^{*5}	P _{min}	-	-	-23	dBm
Overload Power	P _{max}	-10	-	-	dBm
Optical Center Wavelength	λ_C	1270	1550	1600	nm
Receiver Reflectance	R _f	-	-	-27	dB
LOS De-Assert	LOS _{DEASS}	-	-	-24	dBm
LOS Assert	LOS _{ASS}	-34	-	-	dBm
LOS Hysteresis		1	-	-	dB

Note5: Back to back, measured with a PRBS 2³¹-1 test pattern and ER=9dB, BER 1X10⁻¹².

Pin Descriptions

Pin	Symbol	Name/Description
1	GND	Module Ground
2	VEE5	Optional -5.2 Power Supply – Not required
3	Mod-Desel	Module De-select; When held low allows the module to respond to 2-wire serial interface commands
4	Interrupt	Interrupt (bar); Indicates presence of an important condition which can be read over the serial 2-wire interface
5	TX_DIS	Transmitter Disable; Transmitter laser source turned off
6	VCC5	+5 Power Supply
7	GND	Module Ground
8	VCC3	+3.3V Power Supply
9	VCC3	+3.3V Power Supply
10	SCL	Serial 2-wire interface clock
11	SDA	Serial 2-wire interface data line
12	Mod_Abs	Module Absent; Indicates module is not present. Grounded in the

		module.
13	Mod_NR	Module Not Ready;
14	RX_LOS	Receiver Loss of Signal indicator
15	GND	Module Ground
16	GND	Module Ground
17	RD-	Receiver inverted data output
18	RD+	Receiver non-inverted data output
19	GND	Module Ground
20	VCC2	+1.8V Power Supply – Not required
21	P_Down/RST	Power Down; When high, places the module in the low power stand-by mode and on the falling edge of P_Down initiates a module reset
		Reset; The falling edge initiates a complete reset of the module including the 2-wire serial interface, equivalent to a power cycle.
22	VCC2	+1.8V Power Supply – Not required
23	GND	Module Ground
24	RefCLK+	Reference Clock non-inverted input, AC coupled on the host board – Not required
25	RefCLK-	Reference Clock inverted input, AC coupled on the host board – Not required
26	GND	Module Ground
27	GND	Module Ground
28	TD-	Transmitter inverted data input
29	TD+	Transmitter non-inverted data input
30	GND	Module Ground

Pin arrangement

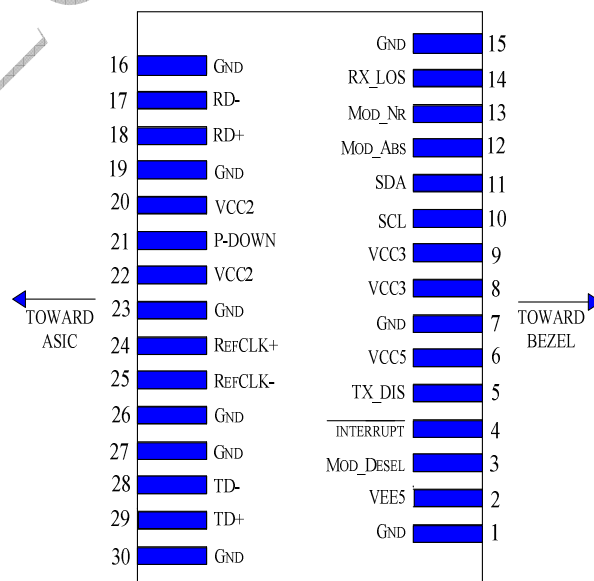

Digital Diagnostic Functions

Eoptolink's EOLX-1596-80 Small Form Factor 10Gbps (XFP) transceivers are compliant with the current XFP Multi-Source Agreement (MSA) Specification Rev 4.5.

As defined by the XFP MSA, Eoptolink XFP transceivers provide digital diagnostic functions via a 2-wire serial interface, which allows real-time access to the following operating parameters:

- ◆ Transceiver temperature
- ◆ Laser bias current
- ◆ Transmitted optical power
- ◆ Received optical power
- ◆ Transceiver supply voltage

It also provides a sophisticated system of alarm and warning flags, which may be used to alert end-users when particular operating parameters are outside of a factory-set normal range.

The operating and diagnostics information is monitored and reported by a Digital Diagnostics Transceiver Controller inside the transceiver, which is accessed through the 2-wire serial interface. When the serial protocol is activated, the serial clock signal (SCL pin) is generated by the host. The positive edge clocks data into the XFP transceiver into those segments of its memory map that are not write-protected. The negative edge clocks data from the XFP transceiver. The serial data signal (SDA pin) is bi-directional for serial data transfer. The host uses SDA in conjunction with SCL to mark the start and end of serial protocol activation. The memories are organized as a series of 8-bit data words that can be addressed individually or sequentially. The 2-wire serial interface provides sequential or random access to the 8 bit parameters, addressed from 000h to the maximum address of the memory.

Recommended Host Board Power Supply Circuit

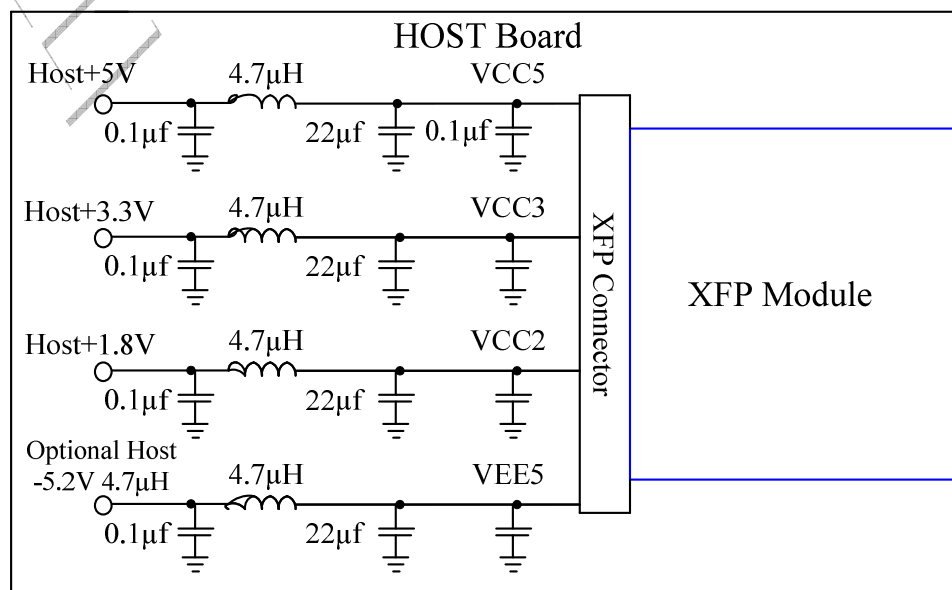

Recommended High-Speed Interface Circuit

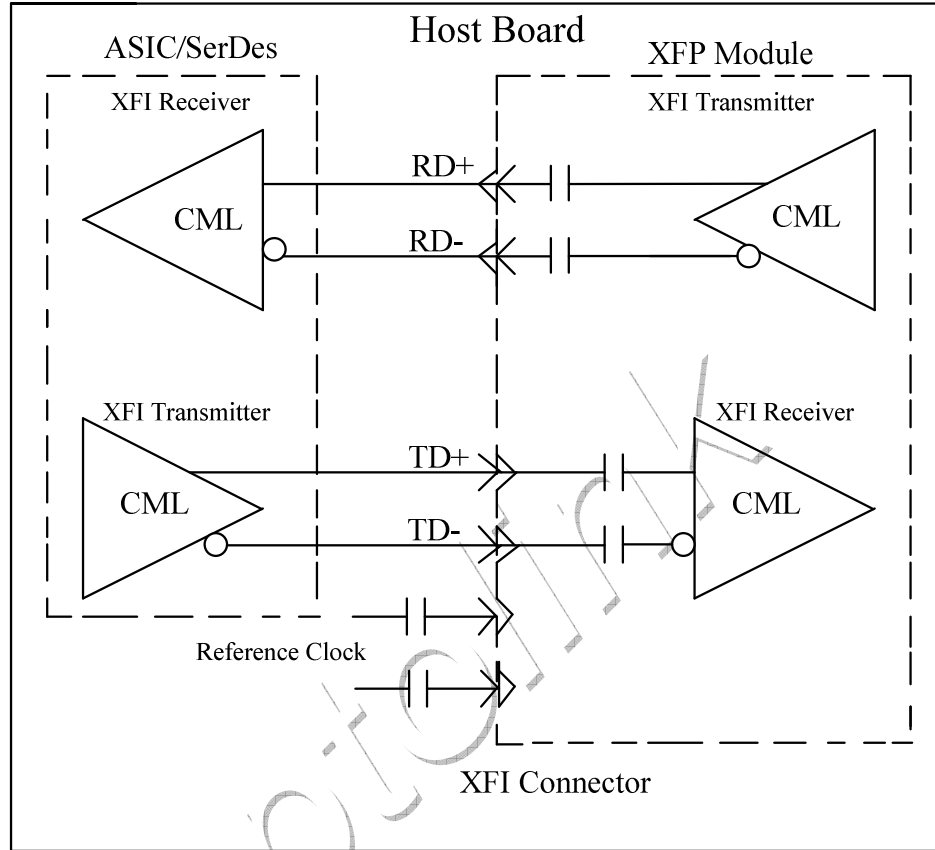

Mechanical Specifications

Eoptolink's XFP transceivers are compliant with the dimensions defined by the XFP Multi-Sourcing Agreement (MSA).

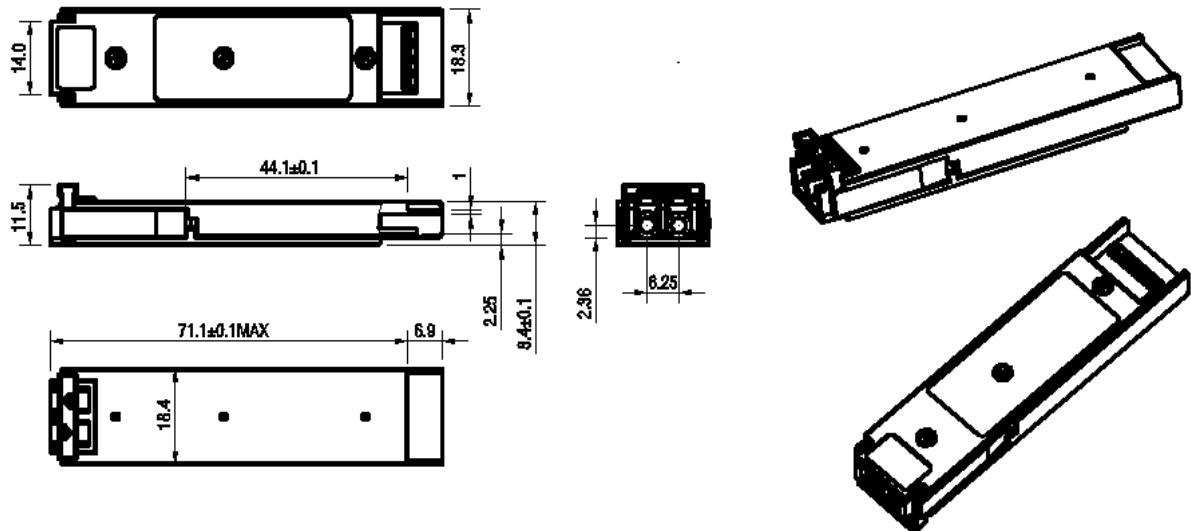

Eye Safety

This single-mode transceiver is a Class 1 laser product. It complies with IEC-60825 and FDA 21 CFR 1040.10 and 1040.11. The transceiver must be operated within the specified temperature and voltage limits. The optical ports of the module shall be terminated with an optical connector or with a dust plug.

Obtaining Document

You can visit our website:

<http://www.eoptolink.com>

Or contact Eoptolink Technology Inc., Ltd. listed at the end of the documentation to get the latest documents.

Revision History

Revision	Initiated	Reviewed	Approved	Revision History	Release Date
V2.b	Kelly Cao			Released.	July 18, 2008
V2.c	Kelly.Cao			Delete the item7 in note3.	June 20, 2009
V2.d	Kelly.Cao			Add the industrial product.	Nov 18, 2009
V2.e	Kelly.Cao			Correct sensitivity description.	Dec 30, 2009
V2.f	Kelly.Cao			Correct laser type and change the logo.	Jan 4, 2010
V2.g	Kelly.Cao			Add max. input power and overload power.	Apr 9, 2010

Notice:

Eoptolink reserves the right to make changes to or discontinue any optical link product or service identified in this publication, without notice, in order to improve design and/or performance. Applications that are described herein for any of the optical link products are for illustrative purposes only. Eoptolink makes no representation or warranty that such applications will be suitable for the specified use without further testing or modification.

Contact:

Add: Floor 5, Building 2, No. 21 Gaopeng Avenue, High-Tech District, CHENGDU, SICHUAN
610041 P.R. CHINA

Tel: (+86) 028-85122709 ext 816 & 809

Fax: (+86) 028-85121912

Postal: 610041

E-mail: sales@eoptolink.com

<http://www.eoptolink.com>

Eoptolink